

PARTS MANUAL

WX520L Serial Number 2EUS1111ES250627 & Up

WX520, WX520T Serial Number 250627 & Up

WX520 / 520L, WX520T **TRAILER LOG SPLITTER**

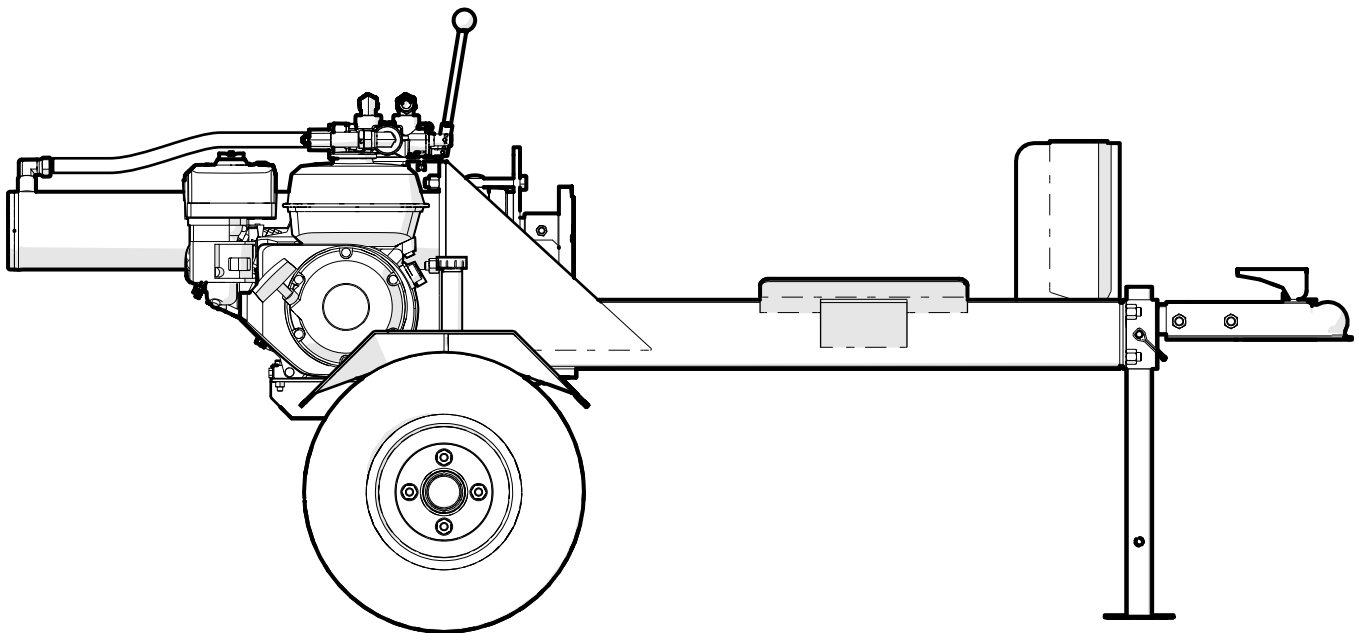

Foreword

This Wallenstein parts manual is prepared to assist customers in ordering quality OEM replacement parts.

Regular maintenance combined with replacing old, worn or broken parts with the correct OEM parts is essential in prolonging the life of your Wallenstein product. Refer to this manual to identify replacement parts.

To order parts, contact your Wallenstein dealer or distributor. Have the product model and serial number handy.

If your dealer is no longer available, please go to our website: <http://wallensteinequipment.com> and click on the **Dealer Locator** to find the nearest dealer.

All information contained in this parts manual is current as per the revision date at the bottom of the page. Wallenstein reserves the right to change product specifications at any time without notice.

If your product specifications differ from those contained in this manual, contact Wallenstein for current information.

Reproduction of information in this parts manual is prohibited without prior written permission from Wallenstein Equipment Inc.

Wallenstein Equipment Inc. • © 2018

WARNING!

Refer to the operators manual for safe operation and maintenance.

Maintenance should be performed by trained personnel only.

Serial Number Location

Always provide the model and serial number of your Wallenstein product when ordering parts or requesting service or other information. This information is found on the product information plate as shown below.

Record product information for future reference.

Model _____

Serial Number _____

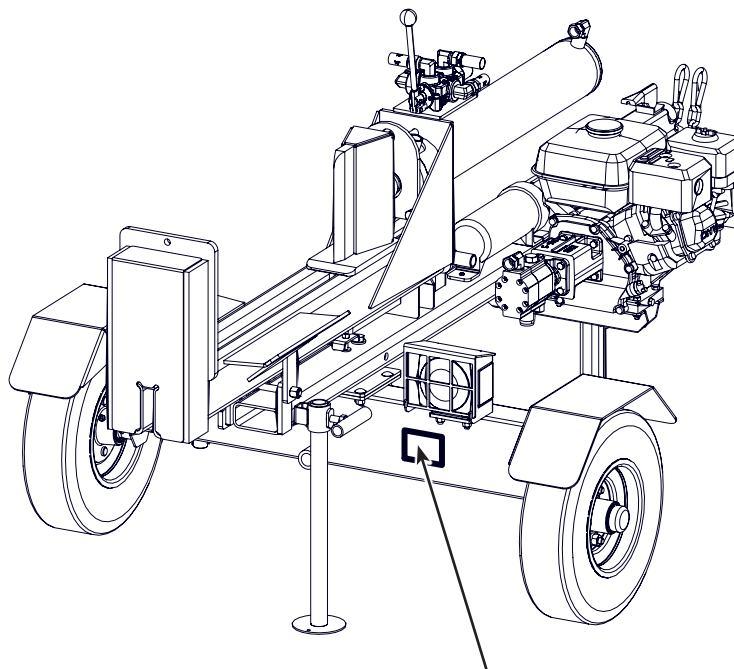

Product Model and Serial Number

www.wallensteinequipment.com

Contents

Main Parts	4
Splitter Base	5
Splitter Tank	6
Engine and Hydraulics Assembly	7
Hub Assembly	8
Hitch Assembly	9
Valve Assembly	10
Hydraulic Plumbing Diagram	11
WX520L Lighting	12
Common Bolt Torque Values	15
Hydraulic Fitting Torque Values	16
Wheel Lug Torque Values	16

Main Parts

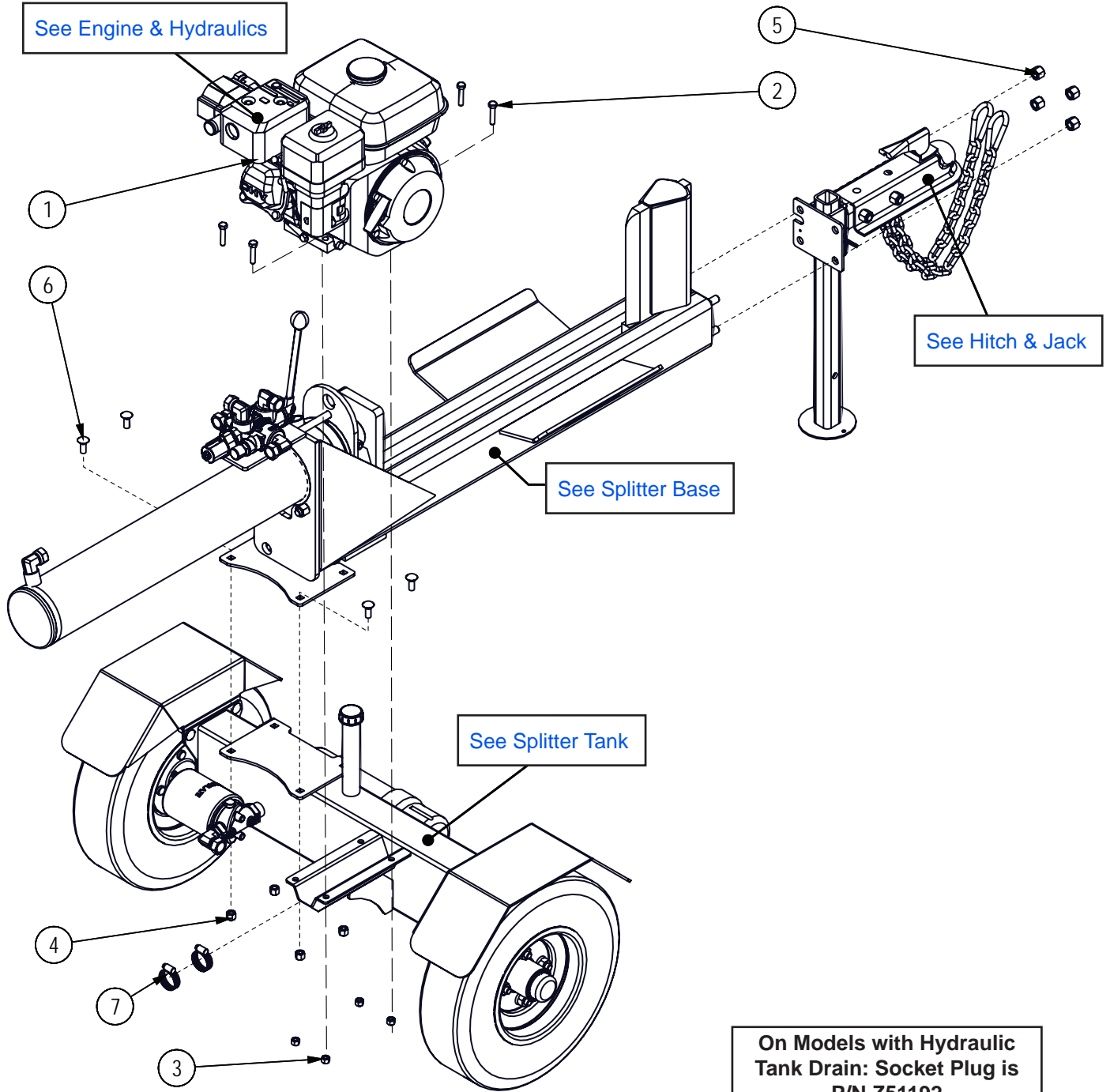

Item No.	Description	Description	Qty
1	2052A205	Assembly, GX 5.5hp Engine to 11gpm Pump	1
2	Z71215	Hex Bolt, 5/16NC x 1-1/2"	4
3	Z72221	Hex Lock Nut, 5/16NC	4
4	Z72231	Hex Lock Nut, 3/8NC	4
5	Z72251	Hex Lock Nut, 1/2NC	4
6	Z76231	Carriage Bolt, 3/8NC x 1"	4
7	Z79401	Hose Clamp, SAE #16 (1-1/2")	2

ECN0396

Splitter Base

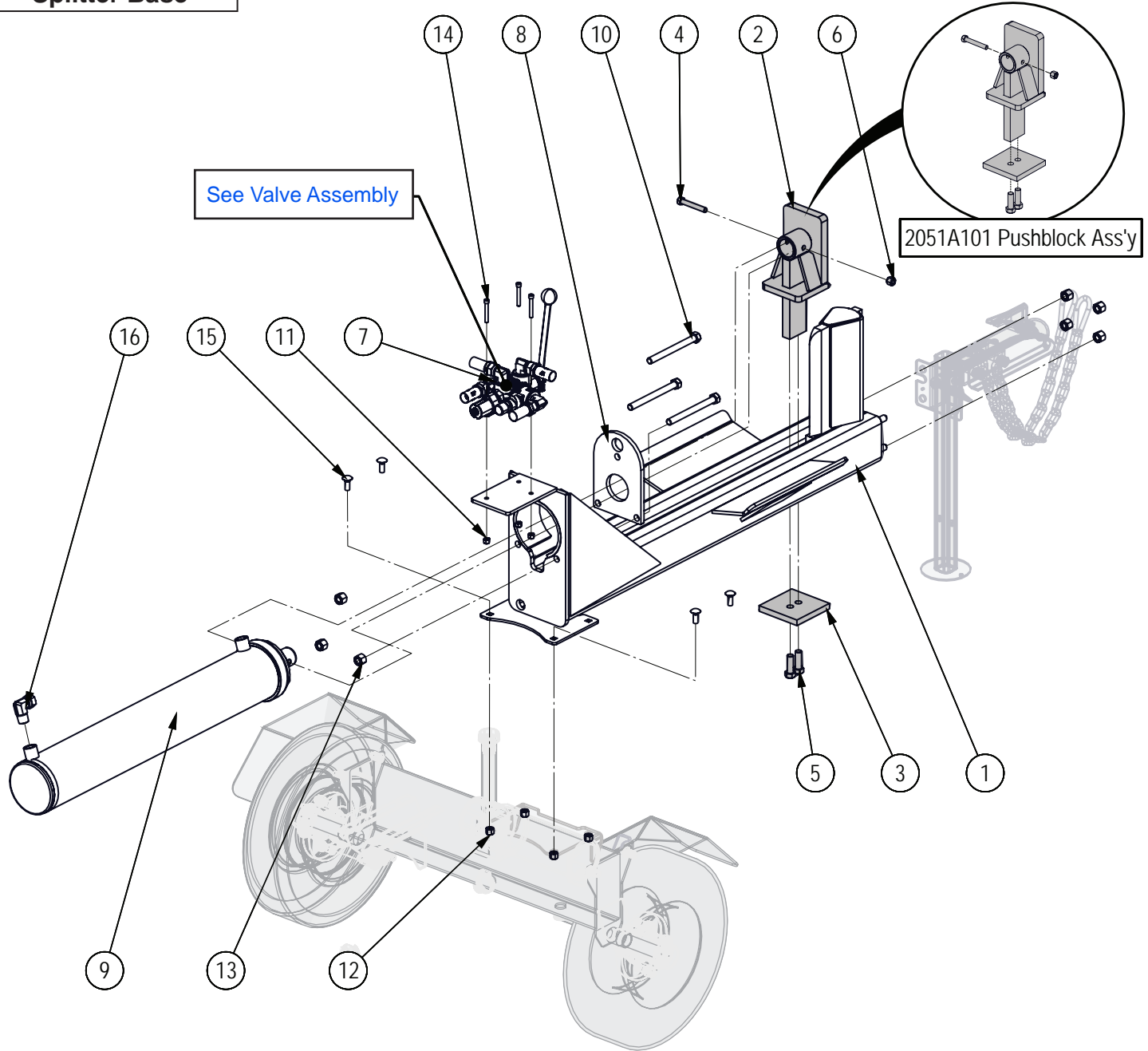

Item No.	Part No.	Description	Qty
1	2052W702	WX520 Base	1
2	2051W102	PushBlock	1
3	2051S117	Sliding Wedge Cap, Bolt-on	1
4	Z71325	Hex Bolt, 3/8NC x 2-1/2"	1
5	Z71576G8	Hex Bolt, 1/2NF x 1-1/2" G8	2
6	Z72231	Hex Lock Nut, 3/8NC	1
7	2011A103	Assembly, Valve with Fittings	1
8	2014S421	Plate, Cylinder Retaining (Bolt)	1
9	2011C101	Cylinder, 4 x 24 x 1-1/2	1

Item No.	Part No.	Description	Qty
10	Z71555	Hex Bolt, 1/2NC x 5-1/2"	3
11	Z72211	Hex Lock Nut, 1/4NC	3
12	Z72231	Hex Lock Nut, 3/8NC	4
13	Z72251	Hex Lock Nut, 1/2NC	7
14	Z75114	SHCS, 1/4NC x 1-3/4"	3
15	Z76231	Carriage Bolt, 3/8NC x 1"	4
16	Z51331	Elbow 90, MP x FPX 0808	1

Splitter Tank

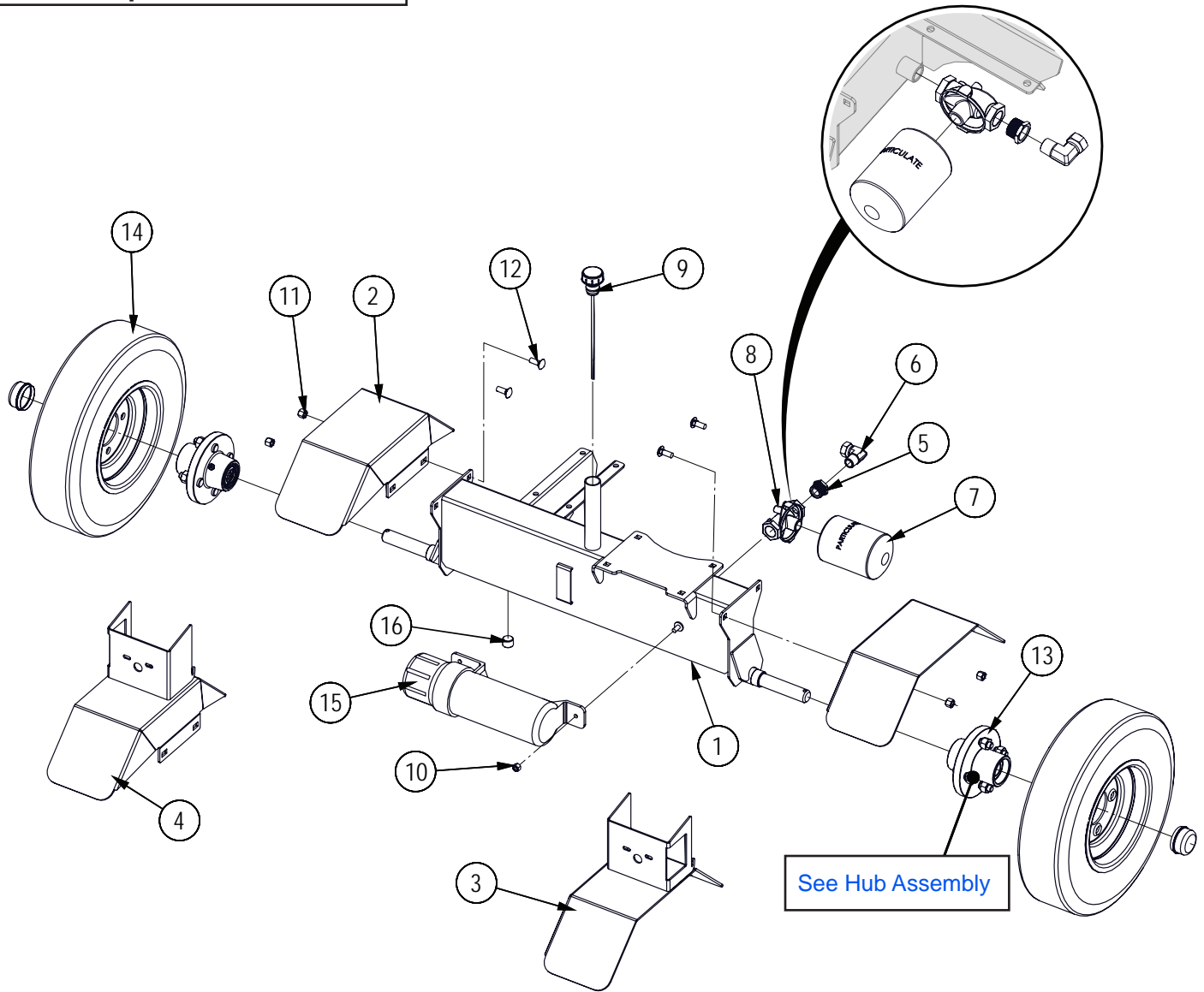

Item No.	Description	Description	Qty
1	2052W707	WX520 Main Base	1
2	2054W408	Fender - WX520 & WX520T	2
3	2054W408-LLH	LH Fender for Light Kit - WX520L	1
4	2054W408-LRH	RH Fender for Light Kit - WX520L	1
5	Z51221	Straight, MP x FP 1208	1
6	Z51331	Elbow 90, MP x FPX 0808	1
7	Z55301	Particulate Filter, FP12	1
8	Z55302	Filter Cap, MP12 x FP12	1
9	Z55404	Vented Plug Dipstick x 9"	1
10	Z72221	Hex Lock Nut, 5/16NC	1
11	Z72231	Hex Lock Nut, 3/8NC	4
12	Z76231	Carriage Bolt, 3/8NC x 1"	4
13	Z91202	Idler Hub Assy, 1000lbs x 4on4" x 1"	2
14	Z91301	4.80-8 LRB SportTrail 4on4"	2
15	Z96503	Manual Tube, 3-1/2" Short	1
16	Z51192	Socket Plug, MP 08	1

Note:
 WX520L has 2054W408-LLH and
 2054W408-LRH Fenders for Light Kit

ECN0396

Engine and Hydraulics Assembly

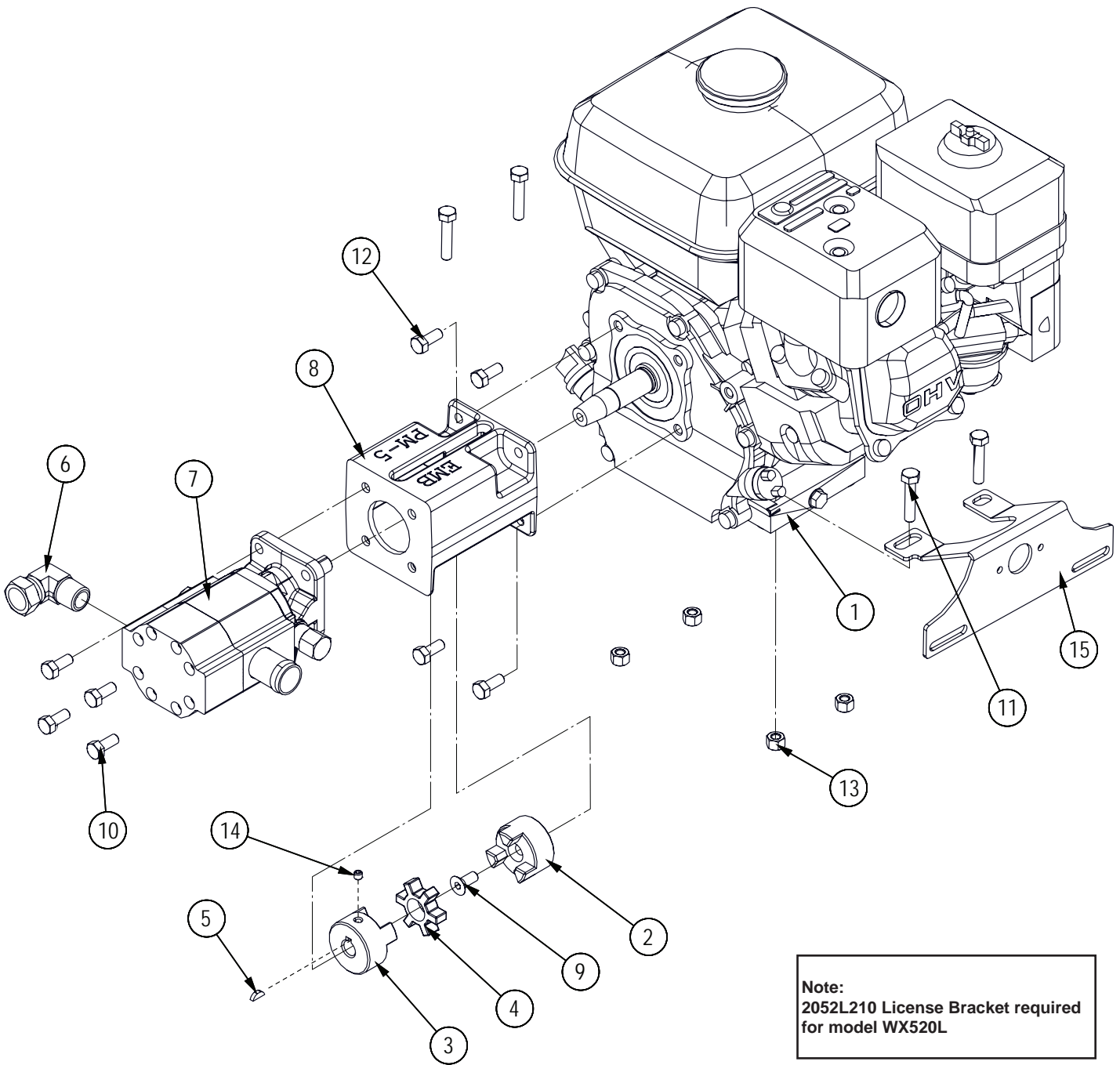

Note:
 2052L210 License Bracket required
 for model WX520L

Item No.	Part No.	Description	Qty
1	Z47128	Honda GX160U1VX2, Taper x Rope	1
2	2052M206	Shaft Coupler, L075 x Taper	1
3	Z46410	Shaft Coupling, L075 x 1/2"	1
4	Z46442	Spider, L075 x Open Center	1
5	Z46592	Woodruff Key, 1/8" x 1/2"	1
6	Z51331	Elbow 90, MP x FFX 0808	1
7	Z53204	Two-Stage Pump, 11GPM	1
8	Z53801	Pump Mount, PM-5	1

Item No.	Part No.	Description	Qty
9	Z75223	FHCS, 5/16NF x 3/4"	1
10	Z71207	Hex Bolt, 5/16NC x 3/4"	4
11	Z71215	Hex Bolt, 5/16NC x 1-1/2"	4
12	Z71273	Hex Bolt, 5/16NF x 3/4"	4
13	Z72221	Hex Lock Nut, 5/16NC	4
14	Z74111	Set Screw, 1/4NC x 1/4"	1
15	2052L210	License Bracket - WX520L Only	1

ECN0396

Hub Assembly

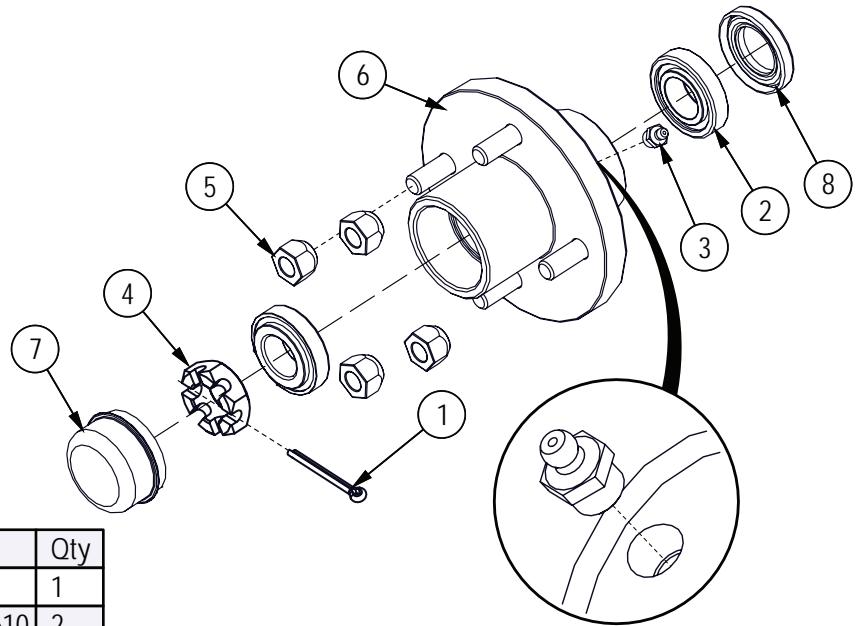

Item No.	Part No.	Description	Qty
1	Z12321	Cotter Pin, 3/16" x 1-3/4"	1
2	Z23201	Roller Bearing, L44643 L44610	2
3	Z29201	Grease Fitting, MP02	1
4	Z72691	Castle Nut, 1NF x 9/16" Thick	1
5	Z72931	Lug Nut, 1/2NF	4
6	Z91201	Hub, 1000lbs x 4on4	1
7	Z91801	Dust Cap, 1.98 Bore	1
8	Z28301	Double Lip Seal, 1-1/4"	1

Cylinder Assembly

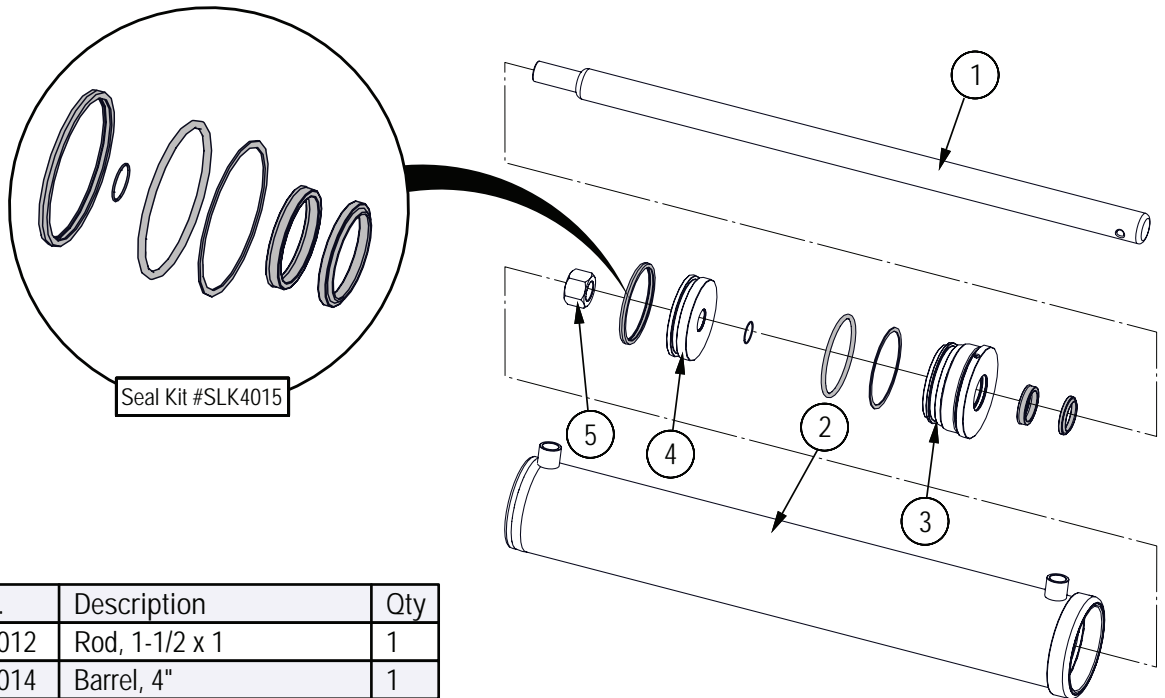

Item No.	Part No.	Description	Qty
1	2011C1012	Rod, 1-1/2 x 1	1
2	2011C1014	Barrel, 4"	1
3	G400-150S	Gland, 4" x 1-1/2"	1
4	P100-400SP	Piston, 4" Bore	1
5	Z72292G8	Hex Lock Nut 1NF Grade 8	1

Hitch Assembly

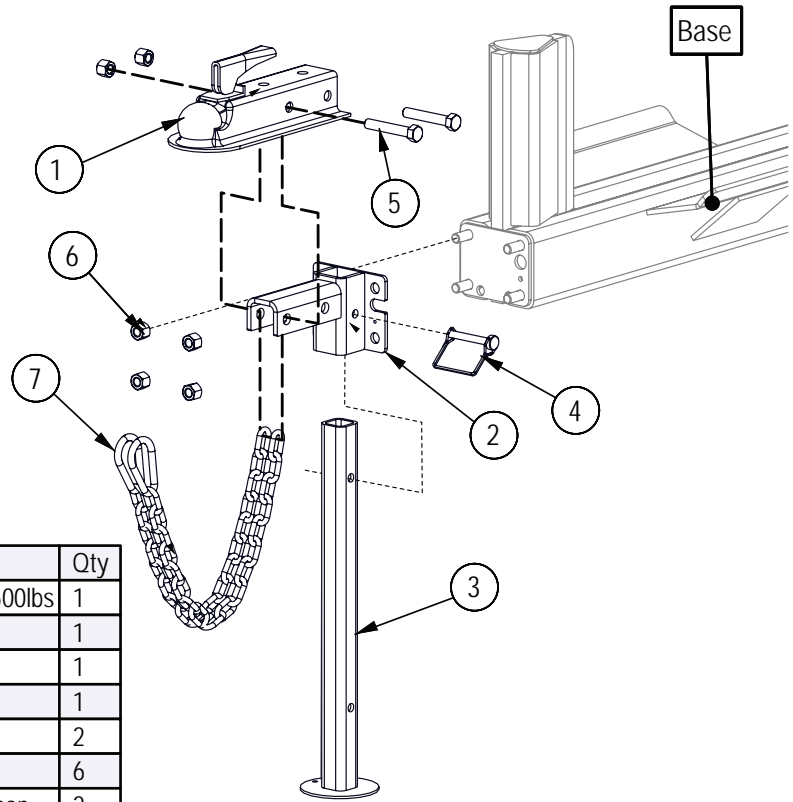

Item No.	Part No.	Description	Qty
1	Z91614	Hitch Coupler, 2" Ball x 2" x 3500lbs	1
2	2052W704	Hitch Mount	1
3	2052W206	Jack Stand, Front	1
4	Z12432	Snap Lock Pin, 3/8" x 2-1/2"	1
5	Z71530	Hex Bolt, 1/2NC x 3"	2
6	Z72251	Hex Lock Nut, 1/2NC	6
7	Z92303	Safety Chain, 1/4" x 2ft with Snap	2

WX520T Tall Parts

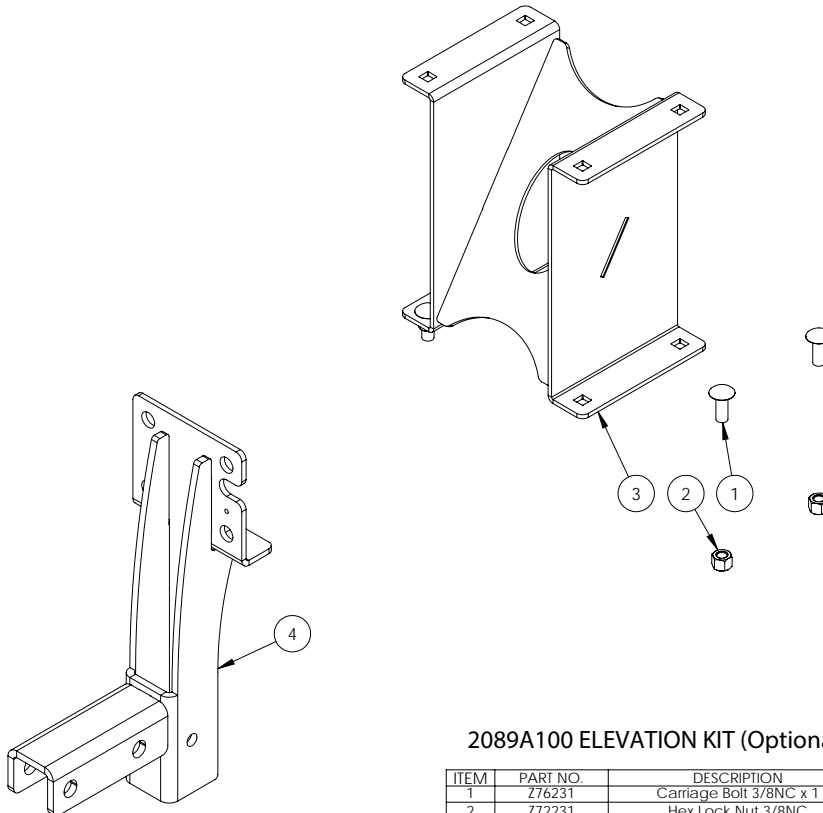

2089A100 ELEVATION KIT (Optional)

ITEM	PART NO.	DESCRIPTION	QTY
1	Z76231	Carriage Bolt 3/8NC x 1	4
2	Z72231	Hex Lock Nut 3/8NC	4
3	2089W101	Tank Spacer	1
4	2089W104	Hitch Mount	1

Valve Assembly

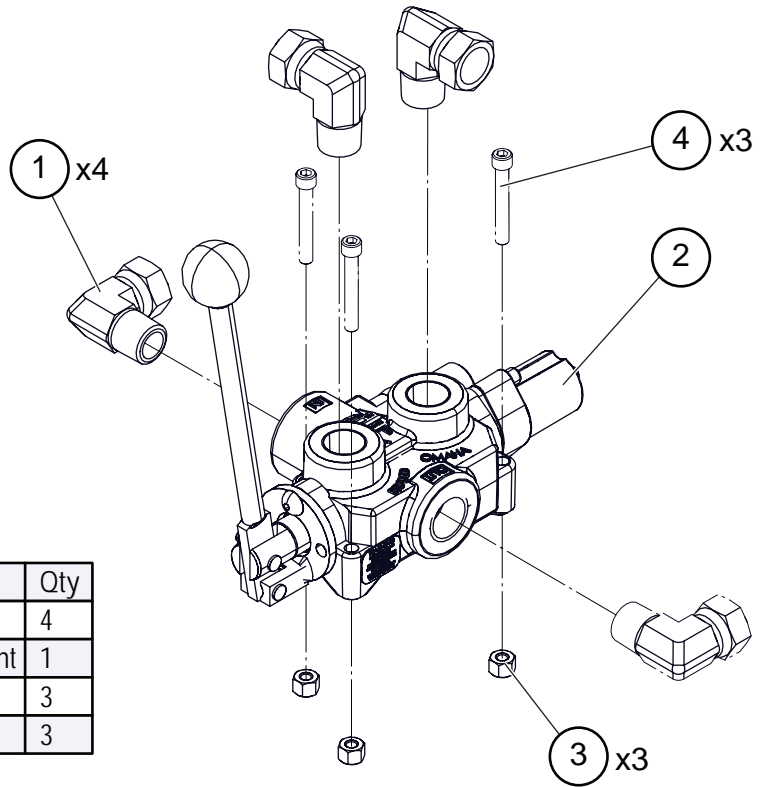

Item No.	Part No.	Description	Qty
1	Z51331	Elbow 90 MP x FPX 0808	4
2	Z56209	Valve, Single Function Detent	1
3	Z72211	Hex Lock Nut, 1/4NC	3
4	Z75114	SHCS, 1/4NC x 1-3/4"	3

Z56209 Service Kits

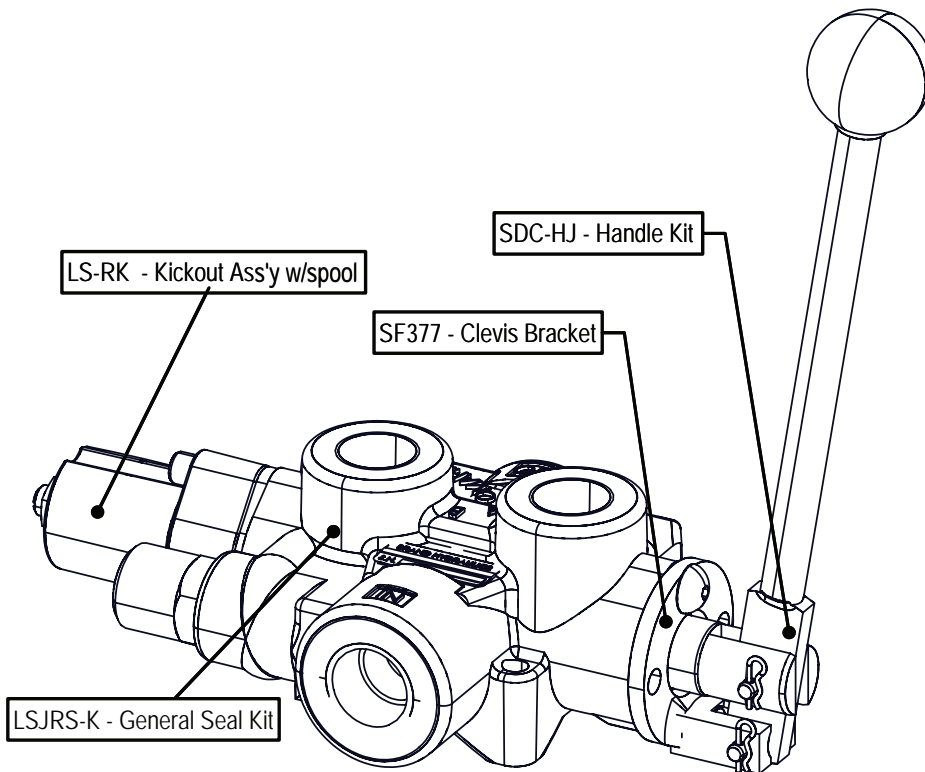

Z56209 Single Spool Valve - PLS50T4JRSHEMB1

Note: Z56210 Closed Center Valve Required For "C" Models

Hydraulic Plumbing Diagram

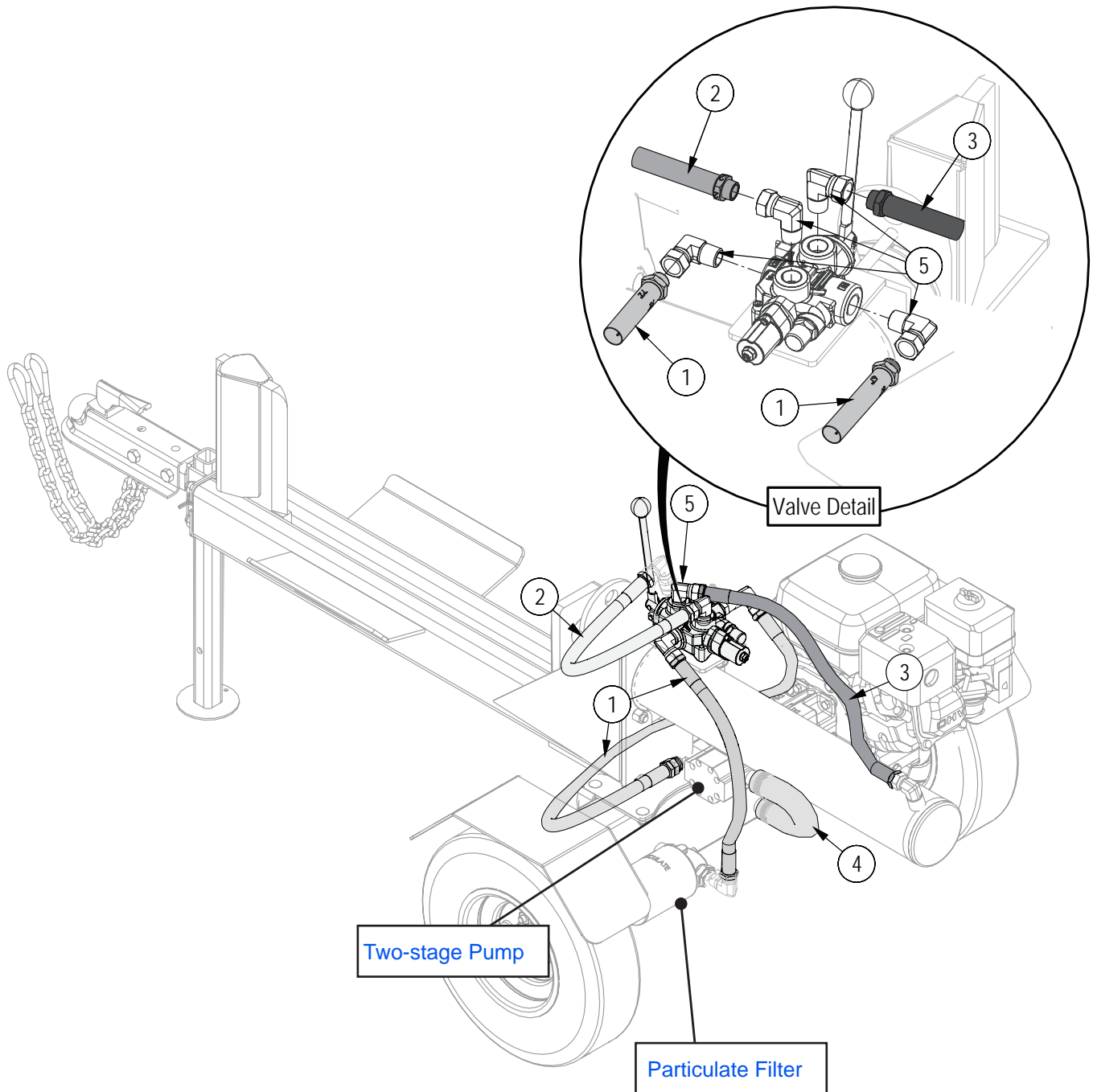

Item No.	Part No.	Description	Qty
1	Z52305	1/2" Hose, MP08 x MP08 x 19"	2
2	Z52301	1/2" Hose, MP08 x MP08 x 13"	1
3	Z52303	1/2" Hose, MP08 x MP08 x 33"	1
4	Z52405	Suction Hose, 1" x 24"	1
5	Z51331	Elbow 90, MP x FPX 0808	4

WX520L Lighting

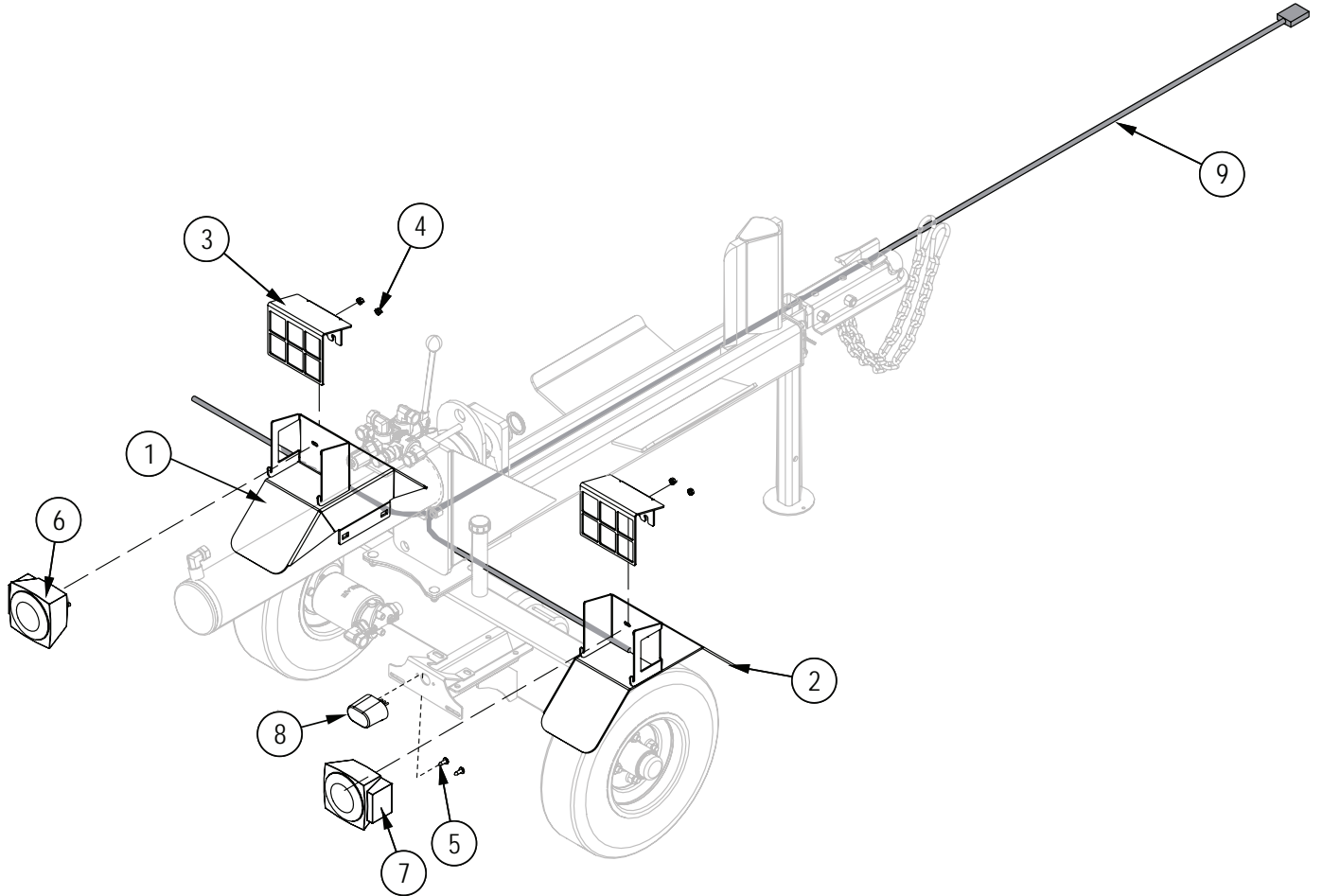

Item No.	Part No.	Description	Qty
1	2054W408-LLH	LH Fender for Light Kit	1
2	2054W408-LRH	RH Fender for Light Kit	1
3	2089L351	Light Guard	2
4	Z72941	Serrated Washer Nut, 1/4NC	4
5	Z76721	Self-tapping Screw, 1/4" x 3/4"	2
6	Z61106	STTL Lamp, Square LH	1
7	Z61107	STT Lamp, Square RH	1
8	Z61301	License Lamp, White	1
9	Z62105	Harness, 110" Lights	1

Decal Layout

IMPORTANT! If parts are replaced that have safety signs on them, new signs must be applied. Safety signs must always be replaced if they become damaged, are removed, or become illegible.

Safety signs are included in the product decal kit available from your authorized dealer. Decals are not available separately.

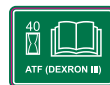
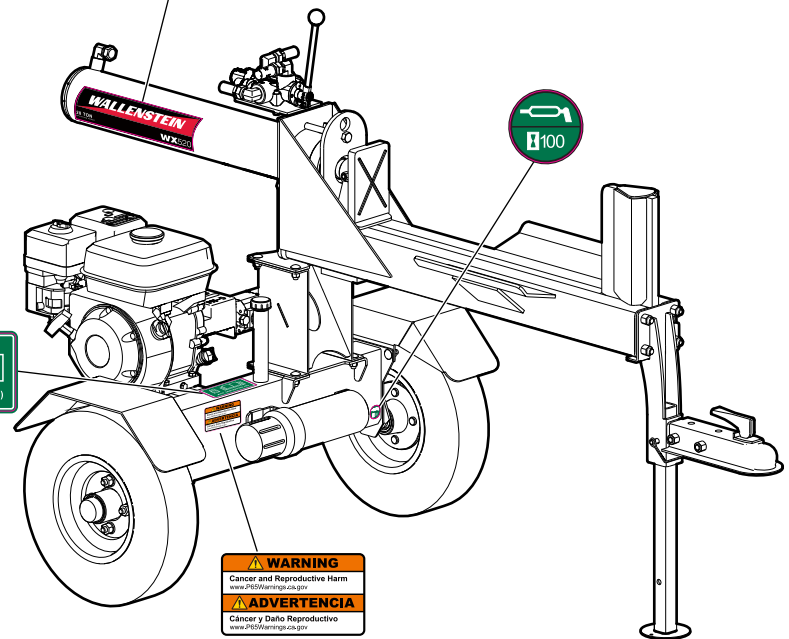
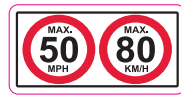
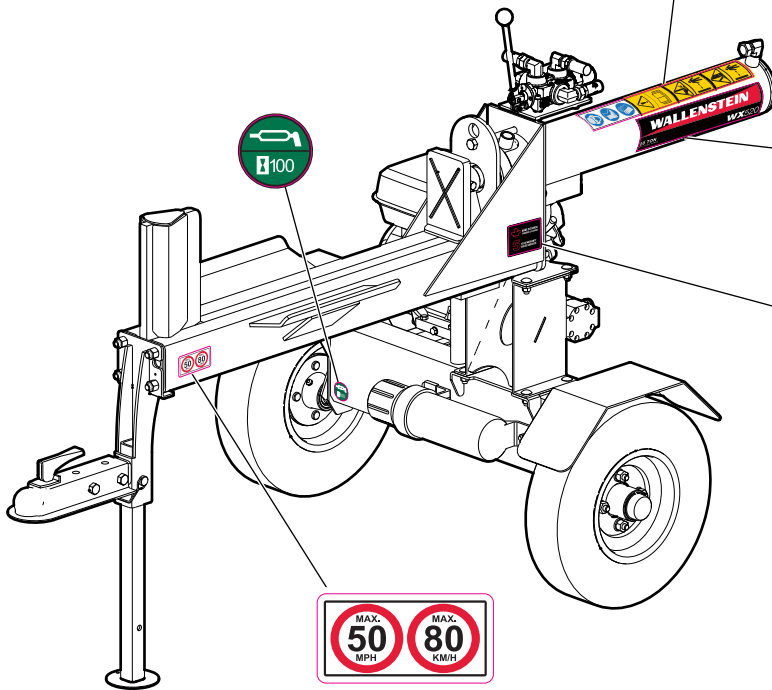
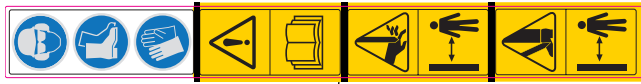

Accessories

Call your dealer for pricing and availability

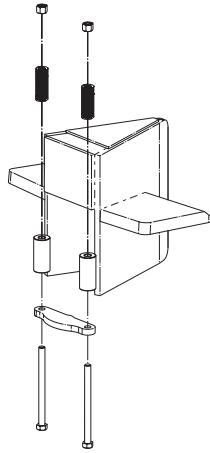
**4-Way Wedge – P/N W4120**

Boost your productivity and make quick work out of logs by splitting four pieces at once. This is an ideal way to save time.

Common Bolt Torque Values

Checking Bolt Torque

The tables shown give correct torque values for various bolts and capscrews. Tighten all bolts to the torque values specified in the table, unless indicated otherwise. Check tightness of bolts periodically.

IMPORTANT! If replacing hardware, use fasteners of the same grade.

IMPORTANT! Torque figures indicated in the table are for non-greased or non-oiled threads. Do not grease or oil threads unless indicated otherwise. When using a thread locker, increase torque values by 5%.

 **NOTE:** Bolt grades are identified by their head markings.

Imperial Bolt Torque Specifications

Bolt Diameter	Torque Value					
	SAE Gr. 2		SAE Gr. 5		SAE Gr. 8	
	lb•ft	N•m	lb•ft	N•m	lb•ft	N•m
1/4"	6	8	9	12	12	17
5/16"	10	13	19	25	27	36
3/8"	20	27	33	45	45	63
7/16"	30	41	53	72	75	100
1/2"	45	61	80	110	115	155
9/16"	60	95	115	155	165	220
5/8"	95	128	160	215	220	305
3/4"	165	225	290	390	400	540
7/8"	170	230	420	570	650	880
1"	225	345	630	850	970	1320



SAE Gr. 2



SAE Gr. 5



SAE Gr. 8

Metric Bolt Torque Specifications

Bolt Diameter	Torque Value			
	Gr. 8.8		Gr. 10.9	
	lb•ft	N•m	lb•ft	N•m
M3	0.4	0.5	1.3	1.8
M4	2.2	3	3.3	4.5
M6	7	10	11	15
M8	18	25	26	35
M10	37	50	52	70
M12	66	90	92	125
M16	166	225	229	310
M20	321	435	450	610
M30	1,103	1 495	1,550	2 100
M36	1,917	2 600	2,700	3 675



8.8



10.9

Hydraulic Fitting Torque Values

Tightening Flare Type Tube Fittings

1. Check flare and flare seat for defects that might cause leakage.
2. Align tube with fitting before tightening.
3. Hand-tighten swivel nut until snug.
4. To prevent twisting the tube, use two wrenches. Place one wrench on the connector body and tighten the swivel nut with the second. Torque to values shown.

If a torque wrench is not available, use the FFFT (Flats From Finger Tight) method.

Hydraulic Fitting Torque					
Tube Size OD	Hex Size Across Flats	Torque value		Flats From Finger Tight	
		lbf•ft	N•m	Flats	Turns
3/16	7/16	6	8	2	1/6
1/4	9/16	11–12	15–17	2	1/6
5/16	5/8	14–16	19–22	2	1/6
3/8	11/16	20–22	27–30	1-1/4	1/6
1/2	7/8	44–48	59–65	1	1/6
5/8	1	50–58	68–79	1	1/6
3/4	1-1/4	79–88	107–119	1	1/8
1	1-5/8	117–125	158–170	1	1/8

Values shown are for non-lubricated connections.

Wheel Lug Torque Values

It is extremely important safety procedure to apply and maintain proper wheel mounting torque on your trailer axle. Torque wrenches are the best method to assure the proper amount of torque is being applied to a fastener.

Wheel lugs should be torqued before first road use and after each wheel removal. Check and re torque after the first 10 miles (16 km), 25 miles (40 km), and again at 50 miles (80 km). Check periodically thereafter.

NOTE: *Wheel lugs must be applied and maintained at the proper torque levels to prevent loose wheels, broken studs, and possible dangerous separation of wheels from your axle.*

- Start all lugs by hand to prevent cross threading.
- Tighten lugs in sequence, per wheel lug torque sequence chart.
- The tightening of the fasteners should be done in stages. Following the recommended sequence, tighten fasteners per wheel torque requirements chart.

Wheel Lug Nut Torque				
Wheel Size	Units	1st Stage	2nd Stage	3rd Stage
8"	lbf•ft N•m	12–20 16–26	30–35 39–45.5	45–55 58.5–71.5
12"	lbf•ft N•m	20–25 26–32.5	35–40 45.5–52	50–60 65–78
13"	lbf•ft N•m	20–25 26–32.5	35–40 45.5–52	50–60 65–78
14"	lbf•ft N•m	20–25 26–32.5	50–60 65–78	90–120 117–156
15"	lbf•ft N•m	20–25 26–32.5	50–60 65–78	90–120 117–156
16"	lbf•ft N•m	20–25 26–32.5	50–60 65–78	90–120 117–156

Wheel Lug Torque Pattern

