

OPERATOR'S MANUAL

QC620 Skid Digger

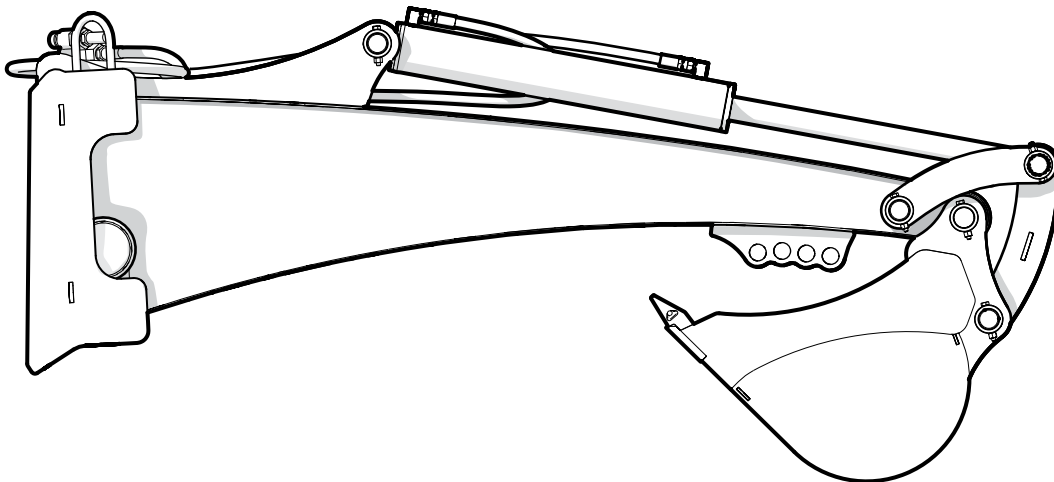

1. Foreword

1.1 Introduction

Congratulations on choosing a Wallenstein QC620 skid digger. This machine is designed and manufactured to meet the needs of the timber and landscaping industries.

The QC620 is a rugged skid digger designed for digging depths up to 6 ft (1.8 m).

Follow the instructions and information in this Operator's Manual for safe, efficient, and trouble-free operation.

The QC620 skid digger is shipped from the factory in a basic, universal configuration and can be mounted to any regular size skid steer model.

Keep this manual handy for reference. Pass it on to new operators or owners, as required. Contact your local Wallenstein dealer or distributor, for assistance, information, or additional copies.



WARNING!

Do not attempt to start or operate the machine without thoroughly reviewing this manual for safe and proper operation.

Always keep this manual with the machine.

W034

Wallenstein Equipment Inc. • © 2021. All rights reserved.

No part of this work may be copied, reproduced, replaced, distributed, published, displayed, modified, or transferred in any form or by any means except with the prior permission of Wallenstein Equipment Inc.



www.wallensteinequipment.com

Table of Contents

1. Foreword	2	9. Troubleshooting Guide	29
1.1 Introduction.....	2	10. Specifications	30
1.2 Delivery Inspection Report.....	4	10.1 Equipment Specifications	30
1.3 Serial Number Location	5	10.2 Accessories	30
1.4 Types of Decals on the Machine	6	10.3 Common Bolt Torque Values	31
2. Safety	7	10.4 Hydraulic Fitting Torque Values.....	32
2.1 Safety Alert Symbol.....	7	11. Product Warranty	33
2.2 Signal Words.....	7	12. Index	34
2.3 Why Safety is Important	7		
2.4 Safety Rules.....	8		
2.5 Equipment Safety Guidelines	8		
2.6 Safe Condition.....	9		
2.7 Safety Training	9		
2.8 Operating Safety.....	9		
2.9 Maintenance Safety	10		
2.10 Set Up a Work Zone.....	11		
2.11 Sign-Off Form	13		
3. Safety Signs	14		
3.1 Safety Sign Locations.....	14		
3.2 Safety Sign Explanations	15		
3.3 Replacing Damaged Safety Signs	16		
4. Familiarization	17		
4.1 To the New Operator	17		
4.2 Operator Orientation	17		
4.3 Skid Digger Components	18		
5. Installation	19		
5.1 Equipment Matching.....	19		
5.2 Attach to a Skid Steer	19		
5.3 Remove from a Skid Steer	20		
6. Controls	21		
7. Operation	22		
7.1 Work Site Safety.....	22		
7.2 Before Startup	22		
7.3 Machine Break-in	23		
7.4 Safe Operating Techniques	23		
7.5 Digging	23		
7.6 Stop and Park	24		
7.7 Stop in an Emergency	24		
7.8 Transport	25		
7.9 Storage	25		
7.10 Place in Storage	25		
7.11 Remove from Storage	25		
8. Service and Maintenance	26		
8.1 Maintenance Safety.....	26		
8.2 Maintenance Schedule	27		
8.3 Grease Points.....	27		
8.4 Replace a Bucket Tooth.....	28		
8.5 Remove the Bucket	28		

1.2 Delivery Inspection Report

Wallenstein Skid Digger

To activate the warranty, register your product at: www.wallensteinequipment.com.

This form must be completed by the dealer at the time of delivery, and then signed by the dealer and customer.

I have received the product manuals and been thoroughly instructed about the care, adjustments, safe operation, and applicable warranty policy.

I have thoroughly instructed the customer about the equipment care, adjustments, safe operation, applicable warranty policy, and reviewed the manuals with them.

Customer

Dealer

Address

Address

City, State/Province, ZIP/Postal Code

City, State/Province, ZIP/Postal Code

()

()

Phone Number

Phone Number

Contact Name

Model

Serial Number

Delivery date

Dealer Inspection Checklist

_____ Check hydraulic hoses.

_____ Check bucket function.

_____ Check that all fasteners are tight.

Lubricate pivot points.

Safety Checks

_____ All safety decals are clean and legible.

_____ Check that hydraulic connections are tight.

_____ Check that hydraulic lines are in good condition.

_____ Check that pin retainers are installed and secure.

_____ Check that Operator's Manual is inside storage tube.

_____ Review operating and safety instructions in the Operator's Manual.

1.3 Serial Number Location

Always provide the model and serial number of your Wallenstein product when ordering parts, or requesting service or other information. The product information plate location is shown in the following illustration.

Record your product Model and Serial Number in the following table for future reference.

Record Product Information Here	
Model:	QC620
Serial Number:	

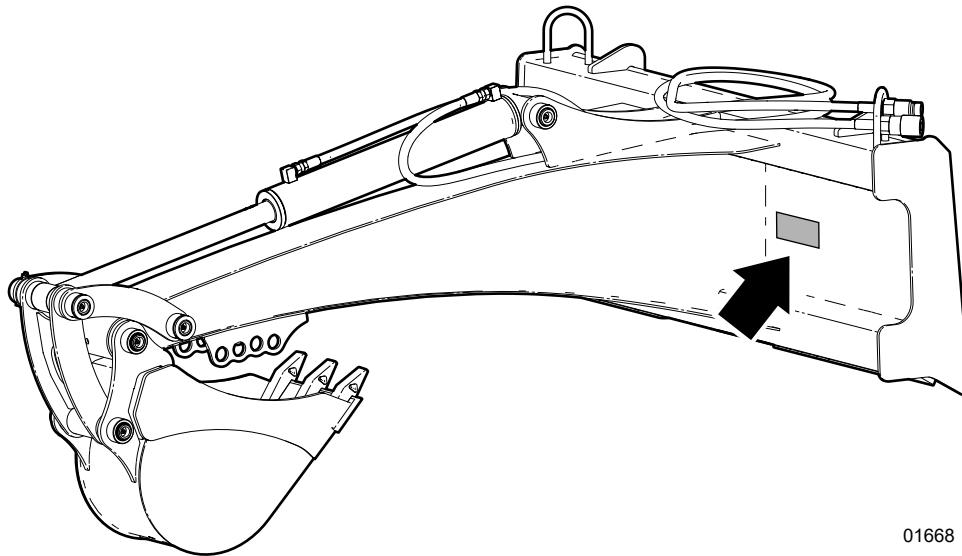

01668

Fig. 1—Serial Number Plate Location (Typical)

1.4 Types of Decals on the Machine

When getting familiar with the Wallenstein product, notice that there are numerous decals located on the machine. There are different types of decals for safety, information, and product identification. The following section explains what they are for and how to read them.

Safety Sign Decals are pictorial with a yellow background and generally two panel. They can be either vertical or horizontal.

The top (or left-hand) panel shows the safety alert (the potential hazard), and the bottom (or right-hand) panel shows the message (how to avoid the hazard).

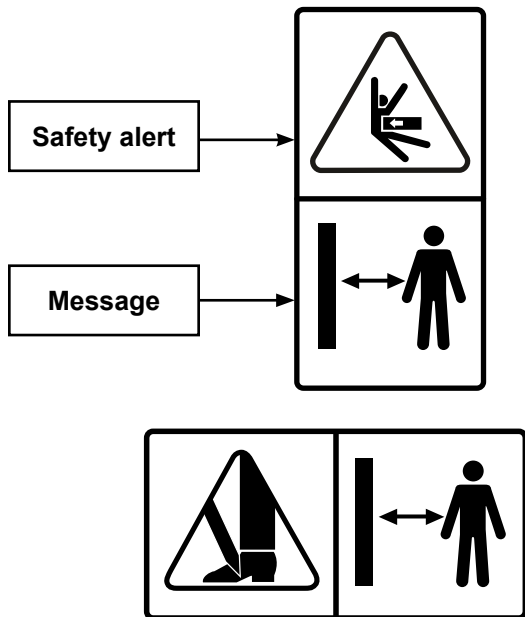

Safety Notice Decals are pictorial with a blue background and generally rectangular with single or multiple symbols. This decal informs what personal protective equipment (PPE) is required for safe operation.



Informative Decals have white symbols on a black background. This type of decal explains the operation of a control.

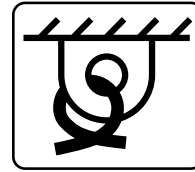

Product Decals indicate machine model and serial number, and other important information.

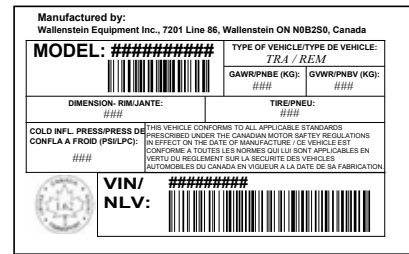

Maintenance Decals have a green background. The decal indicates a maintenance procedure and frequency interval.

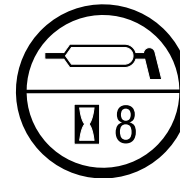

Refer to the section on safety signs for safety decal definitions on *page 15*.

For a complete illustration of decals and decal locations, download the parts manual for your Wallenstein product at www.wallensteinequipment.com.

2. Safety

2.1 Safety Alert Symbol

This Safety Alert Symbol means:

ATTENTION! BE ALERT!

YOUR SAFETY IS INVOLVED!

The Safety Alert Symbol identifies important safety messages on the Wallenstein skid digger and in the manual.

When you see this symbol, be alert to the possibility of personal injury or death. Follow the instructions in the safety message.



2.2 Signal Words

The signal words **DANGER**, **WARNING** and **CAUTION** determine the seriousness level of the warning messages in this manual. The appropriate signal word for each message in this manual has been selected using the following guidelines:

DANGER –

Indicates an imminently hazardous situation that, if not avoided, **will** result in death or serious injury. This signal word is to be limited to the most extreme situations typically for machine components which, for functional purposes, cannot be guarded.

WARNING –

Indicates a potentially hazardous situation that, if not avoided, **could** result in death or serious injury, and includes hazards that are exposed when guards are removed. It may also be used to alert against unsafe practices.

CAUTION –

Indicates a potentially hazardous situation that, if not avoided, **may** result in minor or moderate injury. It may also be used to alert against unsafe practices.

IMPORTANT – To avoid confusing equipment protection with personal safety messages, a signal word **IMPORTANT** indicates a situation that if not avoided, could result in damage to the machine.

2.3 Why Safety is Important

- Accidents disable and kill people.
- Accidents cost money.
- Accidents are preventable.

YOU are responsible for the SAFE operation and maintenance of your Wallenstein product. **YOU** must make sure that anyone who is going to use, maintain, or work around the machine is familiar with the operating and maintenance procedures and related **SAFETY** information contained in this manual. This manual alerts you to good safety practices that should be followed while using your Wallenstein equipment.

YOU are the key to safety. Good safety practices not only protect you, but also the people around you. Make these practices part of your safety program. Make sure that **EVERYONE** using this equipment is familiar with the recommended operating and maintenance procedures, and that they follow all the safety precautions.

Do not risk injury or death by ignoring good safety practices.

2.4 Safety Rules

- It is the operator's responsibility to read, understand and follow ALL safety and operation instructions in this manual. If you do not understand any part of this manual and require assistance, contact your dealer, distributor, or Wallenstein Equipment.
- The operator of the skid digger must be a responsible, physically able person familiar with machinery and trained in this machine's operation.
- Learn the meaning of all the safety signs (decals) that are on the machine. For definitions, see *Safety Sign Explanations on page 15*.
- Review safety related items annually with all personnel who will be operating the machine or performing maintenance.
- Do not expect a person to operate the manure spreader who has not read all the instructions and safety information in this manual. An untrained operator is not qualified and exposes themselves and bystanders to possible serious injury or death.
- Never consume alcohol or drugs prior to or while using this equipment. Alertness or coordination can be affected. Consult your doctor about using this machine while taking prescription medications.
- Wear appropriate PPE when using or servicing this machine. This includes, but is not limited to:
 - A hard hat
 - Hearing protection
 - Protective footwear with steel toes and slip resistant soles
 - Protective glasses, goggles, or a face shield
- Wear hearing protection on a full-time basis if the noise in the operator's position exceeds 80 dB. Noise over 85 dB on a long-term basis can cause severe hearing loss. Noise over 90 dB adjacent to the operator over a long-term basis may cause permanent, total hearing loss.
- Keep a first-aid kit available for use should the need arise and know how to use it.
- Keep a fire extinguisher available for use should the need arise and know how to use it.
- Do not allow long hair, loose fitting clothing, or jewelry near the equipment.

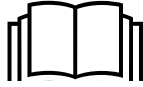

- Know how to stop the equipment quickly in the event of an emergency. For instructions, see *Stop in an Emergency on page 24*.
- Do not install the skid digger on the skid steer if the total skid steer and equipment weight exceeds the rollover protection structure (ROPS) weight certification.
- Have underground utilities located and marked before starting to dig. Take care not to contact overhead and underground obstructions during operation.
- Only operate the machine in daylight or good artificial light.
- Always wear the seat belt when operating the skid steer. Serious injury or even death could result from falling off the skid steer, particularly during a rollover when the operator could be pinned under the machine.
- Do not risk injury or death by ignoring good safety practices.



2.5 Equipment Safety Guidelines

- The skid digger is not intended for use or transport on public roadways. For more information, see *Transport on page 25*.
- Do not dig under the skid steer. A cave-in could result causing the machine to fall into the excavation.
- Never operate the machine with any shield removed. Keep all shields in place. If shield removal is required for service or maintenance, replace the shield prior to using the manure spreader.
- Replace any safety or instruction signs (decals) that are not readable or missing.
- Do not modify the equipment in any way. Unauthorized modification may result in serious injury or death, and may impair the function and life of the equipment. Unapproved modifications void the warranty.
- Make sure that the machine is properly stationed, adjusted, and in good operating condition.
- Do not exceed the skid steer lift capacity. Overloading can cause structural damage and lead to unsafe operating conditions.
- Never exceed the limits of a piece of machinery. If the machine's ability to do a job or to do it safely is in question – **DO NOT TRY IT.**

2.6 Safe Condition

The term **Safe Condition** is referenced throughout this manual. What this means is setting the machine in a state that makes it safe to load, service, maintain, or prepare for storage.

Complete the following to place the machine in a Safe Condition before performing any service, maintenance work, or storage preparation:

Safe Condition
<ol style="list-style-type: none"> 1. Rest the bucket on the ground. 2. Turn off the hydraulic system. 3. Apply the parking brake. 4. Turn off the skid steer engine and remove the ignition key. 5. Activate the hydraulic controls to relieve the pressure. 6. Make sure all components have stopped moving. 7. Block or chock the skid steer wheels.

2.7 Safety Training

Safety is a primary concern in the design and manufacture of Wallenstein products. Unfortunately, efforts to provide safe equipment can be wiped out by a single careless act.

- It is the operator's responsibility to read, understand, and follow ALL safety and operating instructions in this manual. 
- Train all new personnel and review instructions frequently with existing personnel. Make sure that only a properly trained and physically able person uses the machine. A person who has not read and understood all instructions is not qualified to use the machine. An untrained operator can cause serious injury or death to themselves or others.
- Learn the controls and how to stop the machine quickly in the event of an emergency. For instructions, see *Stop in an Emergency on page 24*.
- If the machine is loaned or rented, it is the owner's responsibility to make sure that, prior to using the machine, every operator:
 - Reads and understands this manual.
 - Is instructed in the safe and correct use of the equipment.
 - Knows how to place the machine in a **Safe Condition**. For instructions, see *Safe Condition on page 9*.

2.8 Operating Safety

- Wear appropriate PPE when using or servicing this machine. This includes, but is not limited to:
 - A hard hat
 - Hearing protection
 - Protective footwear with steel toes and slip resistant soles
 - Protective glasses, goggles, or a face shield
- Always wear hearing protection if the noise in any area you work in exceeds 80 dB.
 - Noise over 85 dB on a long-term basis can cause severe hearing loss.
 - Exposure to noise over 90 dB over a long-term basis may cause permanent, total hearing loss.
 - Hearing loss from loud noise (from engines, chain saws, radios, and other such sources close to the ear) is cumulative over a lifetime, without hope of natural recovery.



- Be aware of overhead hazards: branches, cables, electrical wires. Have an underground utility locating/marketing service survey the area before digging.
- Keep boom and bucket away from overhead and underground power lines and utilities. High-voltage power lines can cause electrocution without direct contact.
- Clear the working area of stones, branches, or hidden obstacles that might be hooked or snagged, causing injury or damage.
- Know your controls and how to stop engine and attachment quickly in an emergency.
- Be sure machine is properly mounted, adjusted and in good operating condition.
- Before starting work, complete the tasks described in the *Pre-operation Checklist on page 22*.
- Make sure the skid steer hydraulic system, oil pressure, and flow are matched correctly.
- Never operate controls from the ground. Operate only from the operator's seat to prevent unexpected boom movement that can lead to crushing between frame members. Ensure all control levers are in neutral or off position before starting.
- Keep all bystanders in the designated safe zone during operation. Never carry, lift, or move people on the boom or bucket.
- Do not allow riders on this machine at any time. There is no safe place for any riders.

- Have an assistant on site to help you stay aware of situations that may be dangerous. Have the assistant stay in the designated safe zone, wearing bright, reflective clothing.
 - Inspect and secure all guards before starting.
 - Before exiting the equipment, always lower the bucket to the ground and engage the parking brake.
 - Operate the equipment at a speed that allows you maintain control at all times. Drive slowly over rough terrain and avoid obstacles.
 - Use extreme caution on inclines and edges where the ground could give way.
 - Do not try to turn on a steep slope as this could result in a roll-over.
 - Face the equipment when getting on and off. Maintain 3-point contact with steps and handrails.
 - Never operate this machine under the influence of alcohol or drugs. Consult your doctor about using this machine while taking prescription medications.
 - Position the skid digger so that loads extend directly in front of the machine when lifting or placing heavy objects.
 - Do not walk or work under a raised attachment unless it is securely blocked or held in position. Do not depend on the hydraulic system to hold the load.
 - Skid steer wheels must be resting on the ground during operation. Working with the wheels raised off the ground could result in serious injury or death and may cause damage to the machine.
- Inspect and tighten all bolts, nuts, and screws.
 - Reinstall all safety shields and covers after completing service or maintenance.
 - Use regular cleaners to clean parts. Do not use gasoline.
 - Always use the correct tools for the task, make sure that the tools are in good condition, and understand how to use them.

2.9.1 Hydraulic System Safety

- Make sure that all the components in the hydraulic system are kept clean and in good condition.
- Make sure all components are tight, and that lines, hoses and couplings are not damaged before applying pressure to the system.
- Do not use your hand to check for hydraulic oil leaks. Hydraulic fluid escaping under pressure can penetrate the skin causing serious injury. Use a piece of cardboard instead.
- Wear proper hand and eye protection when searching for a high-pressure hydraulic leak.
- Seek medical attention immediately if injured by a concentrated high-pressure stream of hydraulic fluid. Serious infection or toxic reaction can develop from hydraulic fluid piercing the skin surface.
- Do not attempt any makeshift repairs to the hydraulic lines, fittings, or hoses by using tape, clamps, or cements. Doing so can cause sudden failure and create a hazardous and unsafe condition.
- Relieve pressure on the hydraulic system before working it. The hydraulic system operates under extremely high pressure.
- Replace any hydraulic hose immediately that shows signs of swelling, wear, leaks, or damage before it bursts.
- Do not bend or strike high-pressure lines, tubes or hoses, or reinstall them in a bent or damaged condition.
- Check to make sure hydraulic hoses are not worn or damaged and are routed to avoid chafing.
- Never adjust a pressure relief valve or other pressure-limiting device to a higher pressure than specified.

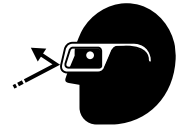

2.9 Maintenance Safety

- Good maintenance is your responsibility. Poor maintenance is an invitation to trouble.
- Read and understand all the information in the Safety section that starts on *page 8*.
- Follow good shop practices that include, but are not limited to the following:
 - Keep the service area clean and dry.
 - Ground electrical outlets and tools correctly.
 - Make sure that there is an adequate amount of light for the current task.
- Never operate the tractor in a closed building. The exhaust fumes may cause asphyxiation.
- Never work underneath equipment unless it is securely supported by blocks.
- Always wear the appropriate PPE.
- When replacement parts are required, only use genuine original equipment manufacturer (OEM) parts. Wallenstein cannot be held responsible for damage or injuries that are caused by use of unapproved parts or accessories.

2.10 Set Up a Work Zone

The safest place for the operator is in the operator's seat. Always operate the skid digger from the operator's seat.

Always be aware of the position of the boom and material being handled.

Be aware of bystanders and workers when moving the skid steer. Make sure they are in the safe zone where they cannot be injured.

Always be aware of hazards such as:

- Underground utilities.
- Tree roots.
- Structures close to the excavation site.
- Excavating on a slope.

Modify the work zone to account for overhead hazards, such as:

- Telephone lines.
- Tree branches.
- Roof overhang.
- Wash lines, ropes, or cables.
- Power lines—maintain a 20 ft (6 m) distance. Electrocutation can occur without direct contact (arcing).

2.10.1 Safe Zone

For the safety of others, during operation set up a **Work Zone** around the area where hazards are present. Mark the area with safety cones. The area outside of the work zone is considered a designated **Safe Zone** for other workers or bystanders.

Always know where all workers and bystanders are when operating the skid digger. Have them stay outside of the work zone in the designated **Safe Zone**. They should only enter the work zone when:

- The person has made eye contact with and signaled the skid digger operator.
- The skid digger is in the transport position or the bucket is resting on the ground.
- The skid steer engine is turned off.

2.10.2 Work Zone

Establish a work zone perimeter that is at least 10 ft (3 m) larger than the space required for the skid steer motion, skid digger motion, excavation, and dirt pile.

While using the skid digger, always be aware of bystanders in the area. The skid steer and boom can create a collision hazard to workers or bystanders. Also, injury may occur from heavy material falling or dropping from the bucket.

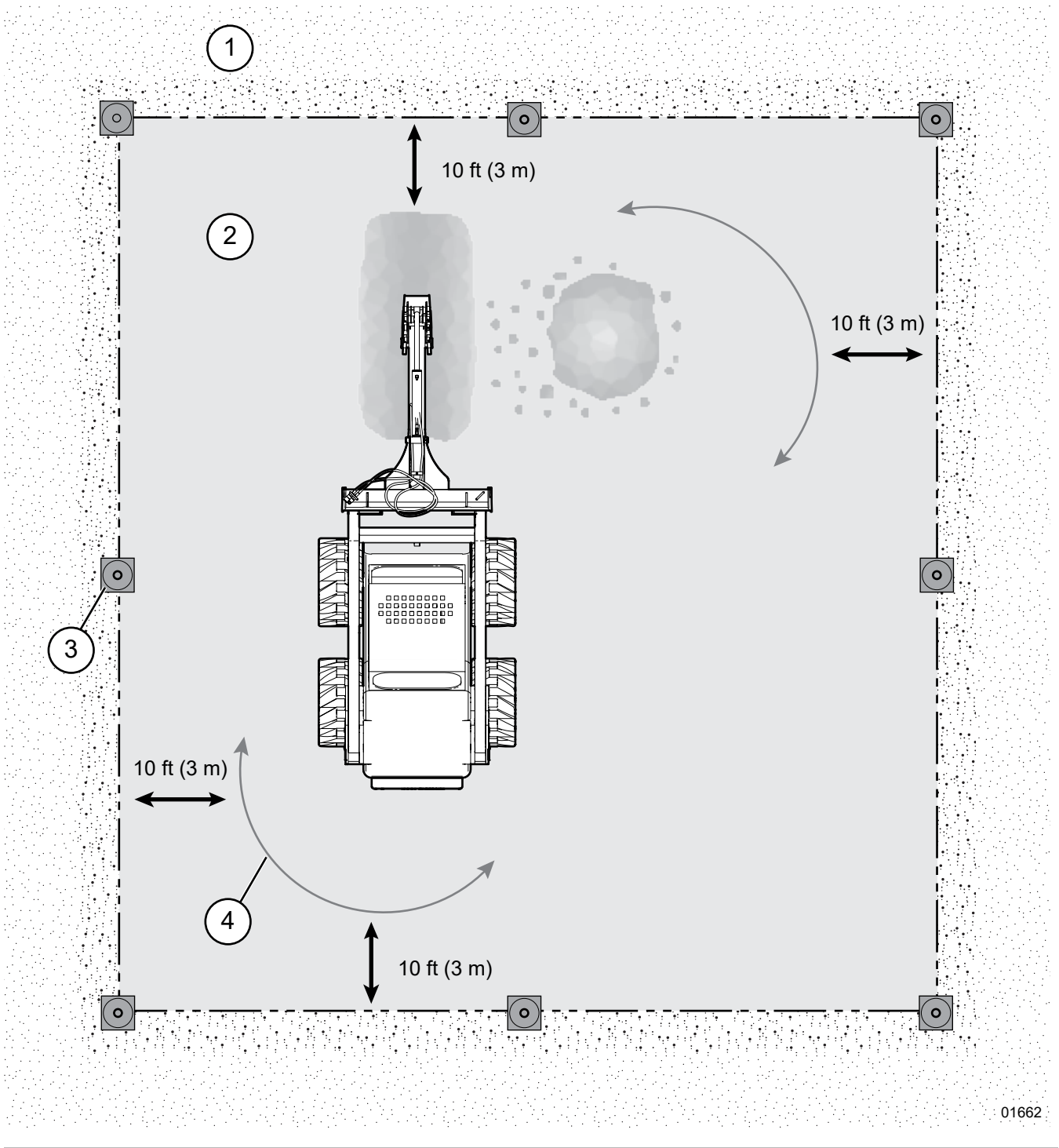

01662

Fig. 2—Establish a work zone perimeter

- 1. Safe zone
- 2. Work zone
- 3. Safety cone (one of eight)
- 4. Back-up space and turning radius

2.11 Sign-Off Form

Anyone using this machine must read and thoroughly understand all Safety, Operation, and Maintenance information in this manual. An untrained operator should never use this machine.

To help document this training, the sign-off sheet provided below can be used.

Make periodic reviews of Safety and Operation a standard practice for all operators. Review again at the startup of every season.

The design and manufacture of this product conforms to relative provisions in the following standards:

- ASABE S318 Safety for Agricultural Field Equipment
- ISO 3600 Operator’s Manual – Machinery for Agriculture, Forestry & Lawn Equipment

Safety

Sign-off Form		
Date	Owner	Employee

3. Safety Signs

3.1 Safety Sign Locations

The location of safety signs on this equipment are shown in the illustrations that follow. **These areas require your safety awareness!**

Become familiar with each warning and the machine function related to that area.

IMPORTANT! If safety signs have been damaged, removed, become illegible or parts replaced without safety signs, new signs must be applied.

(See Safety Sign Explanations starting on page 15.)

Think SAFETY! Work SAFELY!

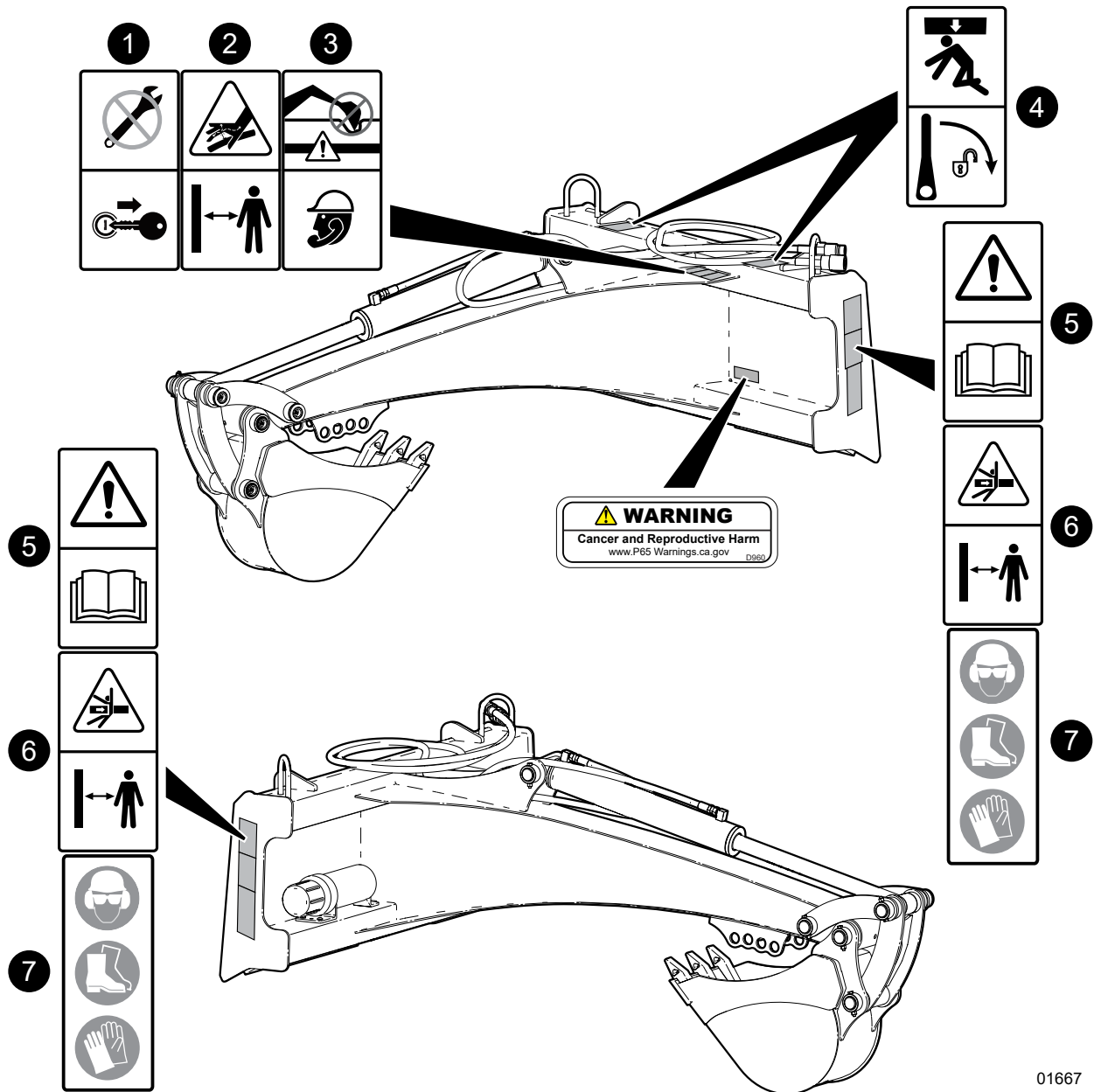

Fig. 3 – Safety Decal Locations (Typical)

Safety

3.2 Safety Sign Explanations

1. Service or Maintenance

Warning! Before performing any service or maintenance, make sure the skid digger is in the transport mode or the bucket is resting on the ground.

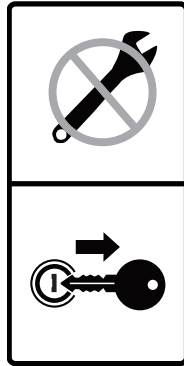

2. Hydraulic System

Warning! Risk of serious injury from injection of high-pressure fluid. Never check for leaks with your hand or finger when system is pressurized. Use caution when removing panels or shields or disconnecting hydraulic connections.



3. Buried Utilities

Warning! Risk of serious personal injury or damage to the skid digger. Be aware of the location of buried utilities (cable, pipes, electrical conduit). Have an underground utility locating/marketing service survey the area before digging.

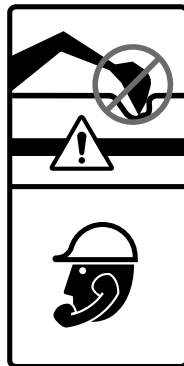

4. Lock Pins

Warning! Make sure lock pins are securely latched before using the equipment. Failure to secure the pins could result in severe personal injury.

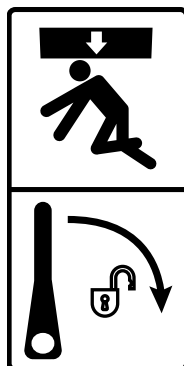

5. Safety Awareness

Caution! Refer to the operator's manual. Read ALL operating instructions in the manual and learn the meaning of ALL safety signs on the machine.

The best safety feature is an informed operator!

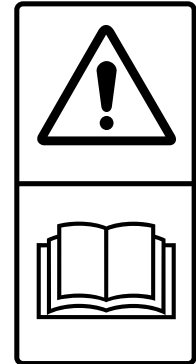

6. Boom and Stabilizers

Warning! Risk of collision or pinching hazard in this area. Stay clear of moving boom and bucket.

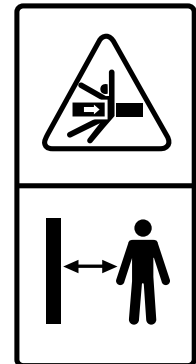

7. Personal Protective Equipment

Caution! Always wear appropriate PPE when using this machine. For example:

- A hard hat.
- Heavy gloves.
- Hearing protection.
- Protective footwear with steel toe and slip resistant soles.
- Protective glasses, goggles, or a face shield.



3.3 Replacing Damaged Safety Signs

IMPORTANT! If parts are replaced that have safety signs on them, new signs must be applied. Safety signs must always be replaced if they become damaged, are removed, or become illegible.

- Always replace safety signs that are missing or have become illegible. Replacement safety signs are available from your authorized distributor, dealer parts department, or Wallenstein Equipment.
- Keep the safety signs clean and legible at all times.
- Parts replaced that had a safety sign (decal) on them must also have the safety sign replaced.

Requirements

- The installation area must be clean and dry.
- The application surface must be clean and free of grease or oil.
- The ambient temperature must be above 50 °F (10 °C).
- A squeegee, plastic bank card, or similar tool is required to smooth out the decal.

Procedure



Determine the exact position for the decal before removing the backing paper. If possible, align the decal with an edge on the machine.

1. Peel the decal off the backing paper.
2. Position the decal above the location where it is being applied to the machine.
3. Starting at one edge, carefully press the center of the exposed sticky-backing in place, smoothing it out as you work from one side to the other.
4. Use an appropriate tool to smooth out the decal, working from one end to the other.

Small air pockets can be pierced with a pin and smoothed out using a piece of the decal backing paper.

4. Familiarization

4.1 To the New Operator

It is the responsibility of the owner or operator to read this manual and to train all other operators before they start working with the machine. Follow all safety instructions exactly.

By following recommended procedures, a safe working environment is provided for the operator, bystanders, and the area around the work site. Untrained operators are not qualified to use the machine.

Many features incorporated into this machine are the result of suggestions made by customers like you. Read this manual carefully to learn how to use the machine safely and provide maximum operating efficiency. By following the instructions in conjunction with a good maintenance program, your skid digger can provide many years of trouble-free service.

IMPORTANT! Make sure all operators understand how to put the skid steer and skid digger in a Safe Condition before working with this equipment. See *Safe Condition* on page 9.

4.1.1 Training

Each operator must be trained in the proper set-up and operating procedures before using the skid digger.

- Move the unit to a large open area to allow the operator to become familiar with control functions and machine response.
- Do not allow untrained operators to use the machine. They can endanger themselves and others, or damage property and the machine.

4.2 Operator Orientation

IMPORTANT! The directions for left-hand, right-hand, backward, and forward mentioned throughout this manual are determined when sitting in the skid steer seat, facing the bucket.

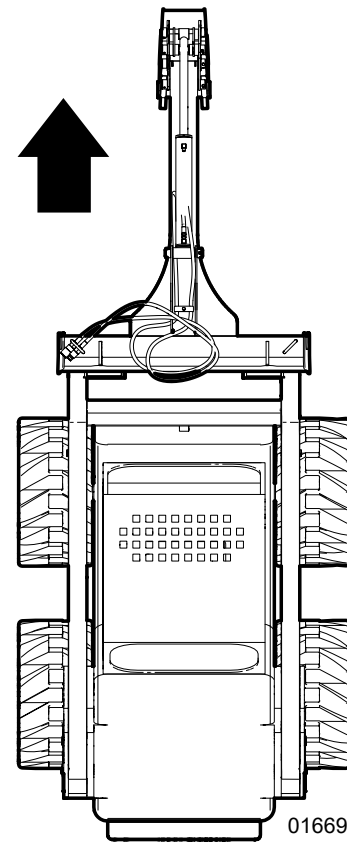

Fig. 4—Operator Orientation

4.3 Skid Digger Components

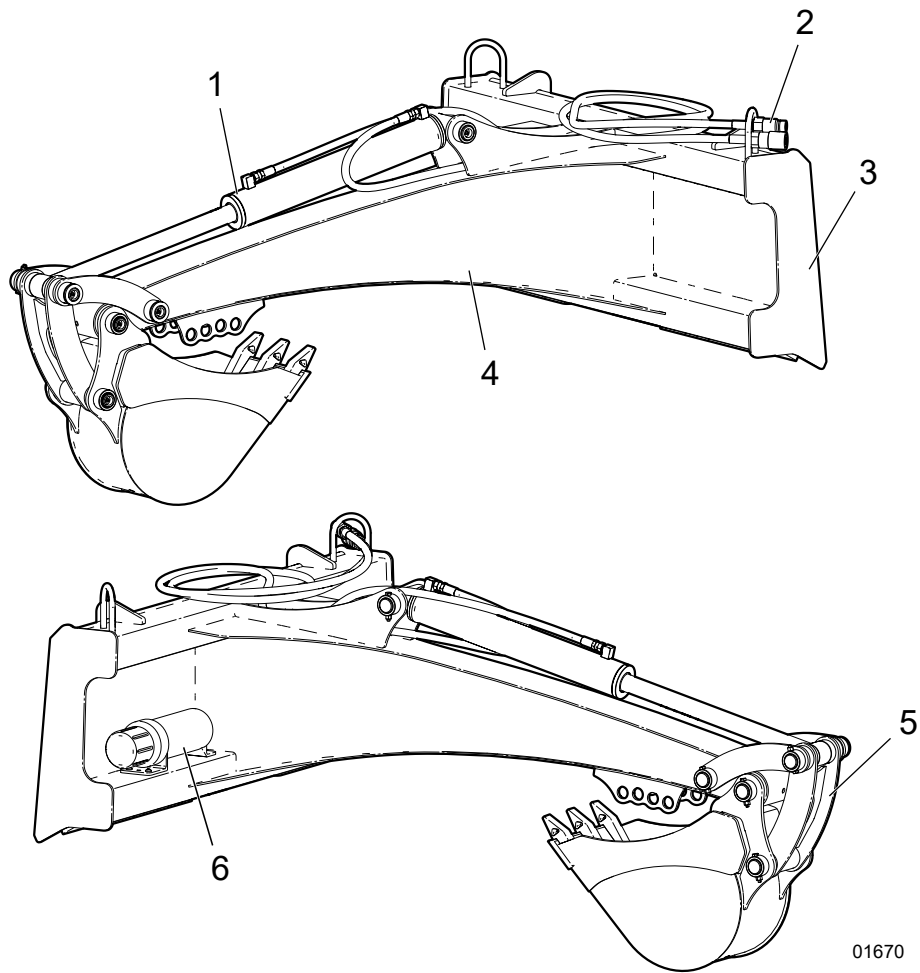

Fig. 5—Skid Digger Components

1. Hydraulic cylinder
2. Hydraulic connections
3. Skid steer mount
4. Main frame and boom
5. Bucket and linkage
6. Operator's Manual tube

5. Installation

WARNING!

Risk of ROPS failure. Do not install a skid digger on a skid steer if the total equipment weight exceeds the ROPS weight certification.

The skid digger is designed to mount on a regular-size (not a mini) skid steer.

5.1 Equipment Matching

To ensure safe and reliable operation of the skid digger, it must be a correct match to your skid steer. The skid steer must be equipped with remote hydraulic connections on the front of the loader frame.

See the skid steer operator's manual for specifications. Use the following requirements as a guide:

- 1. Horsepower:** The recommended skid steer horsepower range is 30–65 hp.
- 2. Skid steer weight:** Comply with the skid steer attachment weight recommendation for stability when digging or transporting.
- 3. Hydraulic system:** The skid steer hydraulic system must be capable of operating between 3–22 gpm (14–83 Lpm) at less than 3,000 psi (20,694 kPa).

5.2 Attach to a Skid Steer

WARNING!

Ensure lock pins are securely latched before operation. Failure to secure pins could result in serious injury or death.

W014

The skid digger is equipped with a universal quick-attach plate that is compatible with skid steer quick-attach hitches. See the skid steer operator's manual for specific mounting instructions.

1. Clear the area of bystanders.
2. Make sure that there is enough room and clearance to safely drive the skid steer to the skid digger, and that the skid steer is square to the mounting plate.
3. Lift the latch arms on the quick-attach hitch and make sure that the latch pins are retracted.
4. Tilt the hitch forward until the top edge of the hitch is below the flange on the rear of the mounting plate and centered between the vertical plates.
5. At the slowest speed possible, drive the skid steer forward to the mounting plate.
6. Tilt the skid steer hitch back to engage the flange on the mounting plate.
7. Turn off the skid steer, apply the parking brake, and then dismount to inspect the pin alignment.
8. Push the latch arms fully down to extend the latch pins through the mounting plate latch-pin mount and secure the skid digger. Make sure that the hitch and latch pins are correctly engaged and secure.
9. Connect the hydraulic lines. Make sure the connections are tight and secure.
10. Start the skid steer engine and slowly cycle the bucket cylinder several times to purge the system of air.
11. Wear heavy gloves and goggles (or a face shield) and use a piece of cardboard or wood to verify that there are no hydraulic leaks.
12. Check the skid steer hydraulic oil level to make sure it is correct.

5.3 Remove from a Skid Steer

WARNING!

Risk of serious injury from escaping high-pressure oil. Actuate controls after engine shut down to relieve trapped pressure before loosening hydraulic connections.

W080

1. Select an area that is dry, level, and free of debris, away from human activity.
2. Retract the bucket and lower the skid digger to the ground. If the ground is soft or wet, set it on wood planks or a pallet.
3. Turn off the skid steer engine. Move the bucket-tilt control lever several times to relieve any trapped pressure in the circuit.
4. Place planks or blocks under the bucket, boom, and base. Make sure the skid digger is stable.
5. Disconnect the hydraulic hoses and cap the lines to prevent dirt from getting into the couplers.
6. Tilt the skid steer hitch forward to disengage the flange on the mounting plate.
7. Push the latch arms fully up to retract the latch pins from the mounting plate latch-pin mount and release the skid digger.
8. Move the skid steer away from the skid digger.

If you are storing the skid digger for an extended length of time, see *Storage on page 25*.

6. Controls

Use the skid steer hydraulic controls to operate the skid digger.

Read and understand the controls section of the skid steer operator's manual. Before using the skid steer, be familiar with the location, settings, and function of the controls.

7. Operation

7.1 Work Site Safety



WARNING!

Electrocution Hazard. Be aware of overhead or underground power lines. Stay at least 20 ft (6 m) or more away. Serious injury or death could occur from electrocution. Electrocution is possible without direct contact (arcing).

W015

- For safety of others during operation, set up a **Work Zone** around the machine. Mark the area with safety cones. For more information, see *Set Up a Work Zone on page 11*.
- Plan your excavation ahead of time. Determine where excavated soil will be dumped. Position the machine to minimize the distance of travel between digging and dumping. The shorter the travel distance, the faster the dig / dump cycle and more work that can be done.
- Be aware of buried or overhead wires, cables, pipes, or other obstructions. Contact your local utility company to mark their location.
- If working in a close or cramped space, be sure there is sufficient room for the machine to dig, swing, and dump. Modify the work site to provide more area. Unplanned contact with adjacent buildings, equipment or terrain can cause loss of control leading to injury or damage.
- Be aware of prevailing winds. Set-up the work site so prevailing winds blow exhaust, dust, and debris away from the operator. As a result, the work zone becomes safer as vision is not be obscured while digging and dumping.
- Do not operate inside a building. Gas and diesel engines produce carbon monoxide that can cause asphyxiation.
- Be aware of bystanders. Do not permit bystanders, on-lookers, or unauthorized personnel in the work area. Stop the machine if anyone enters the working area. There is always the risk of someone getting in the way or getting pinched / caught by components. Do not resume work until the work zone is clear.
- Do not try to lift objects that are beyond the lifting limits of the machine. Be aware of people and objects when lifting. When moving a load, travel slowly and know the travel path.
- The recommended travel for a skid steer is up or down a slope, not across it. Keep the skid digger low to the ground to improve stability. Extra care is required if working on a slope. If working on a slope is necessary, work the boom up-slope to minimize the chance of tipping.

7.2 Before Startup

Each operator must be trained in the proper operating procedures prior to operating the machine.

- Review location of the controls, their function, and movement direction when activated.
- Follow the Pre-Operation Checklist.

7.2.1 Pre-operation Checklist

Before operating the machine, check the following:

Pre-operation Checklist	✓
Check that the skid digger is securely and correctly attached to the skid steer. For instructions, see <i>Attach to a Skid Steer on page 19</i> .	
Check and lubricate the skid digger as described in the <i>Maintenance Schedule on page 27</i> .	
Check for and remove entangled material.	
Check that the bucket linkage moves freely.	
Check the condition of the bucket teeth. If required, replace damaged teeth. For instructions, see <i>Replace a Bucket Tooth on page 28</i> .	
Check that hydraulic hoses are not chafed, pinched, or crimped. Reroute, as required.	
Check for hydraulic leaks. For important safety instructions, see <i>Hydraulic System Safety on page 26</i> . Tighten fittings or replace components to stop leaks. For torque specifications, see <i>Hydraulic Fitting Torque Values on page 32</i> .	
Check all fasteners and hardware. Tighten to the specified torque, as required. For torque specifications, see <i>Common Bolt Torque Values on page 31</i> .	

7.3 Machine Break-in

Although there are no operational restrictions on the skid digger when used for the first time, it is recommended that the following mechanical items be checked:

After operating for 1/2 an hour

1. Check all nuts, bolts, and other fasteners. Tighten to torque specification. See *page 31*.
2. Check the condition of all hydraulic lines, hoses, and fittings. Replace any that are damaged. Re-route those that are rubbing, pinched or crimped. Tighten any fitting that is leaking.
3. Check the condition of the teeth on the bucket. Replace any that are bent, chipped, broken or missing.
4. Check the oil level in the hydraulic reservoir if so equipped. Add as required.
5. Check the boom, dipper, and bucket pivot pins. Be sure all are anchored securely in position.
6. Lubricate all grease points (refer to Maintenance Section for their location).

After operating for 5 hours and 10 hours

Repeat the steps listed under *After operating for 1/2 an hour* on *page 23*.

7.4 Safe Operating Techniques

WARNING!

Underground utility hazard. Contact an underground utility locating and marking service before digging.

W017

- Read and understand the information in the Safety section that starts on *page 7*.
- Review the work site before positioning the skid digger and starting to work:
 - Stay away from utility lines and obstructions.
 - Be aware of overhead hazards.
 - Always have an underground utility locating/marketing service survey the area before digging.
- Use extreme caution when excavating on a slope. Do not excavate across a slope. Make sure the skid steer frame is horizontal. All four wheels must be touching the ground.
- Do not allow untrained personnel to operate the machine.
- Do not operate the machine when unauthorized people are in the work area. Stop until they leave.

- Back away from the hole and turn the skid steer when emptying the bucket.
- Stay away from the edge of the hole.
- Do not undercut the skid steer. Doing so could cause the ground to give way and the skid steer could tip into the excavation.
- Only operate the machine while sitting in the skid steer seat. Never operate controls while standing on the ground.
- Do not carry people on the boom or bucket.
- Do not exceed the skid digger's lift capacity.
- Keep hydraulic components and fittings tight and in good condition.

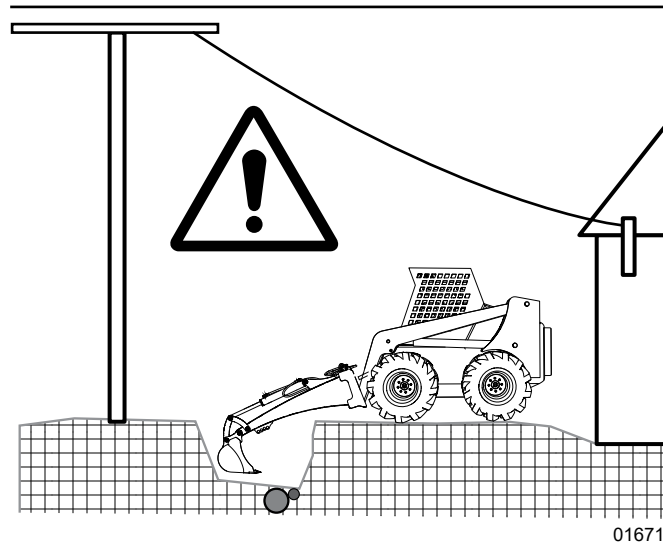

Fig. 6—Be aware of underground and overhead hazards

7.5 Digging

WARNING!

Call or click before you dig! Contact your local underground utility locating and marking service. Make sure the location of buried hazards and infrastructure are marked before you dig.

W099

WARNING!

Avoid risk of falling into the hole or collapsing the sides of the hole. Back away from the hole before rotating machine.

When digging, the loader arms should be partially raised with the bucket pointed outward, away from the operator.

7.5.1 Dig with the Boom

1. Use the loader arms and bucket cylinder to set the bucket at approximately a 30-degree angle into the ground. Set the boom angle so that the bucket teeth are digging and the heel of the bucket is off the ground.
2. Tilt the bucket cylinder to pull the bucket through the soil until it is full.
3. Curl the bucket up and raise the loader arms.
4. Rotate the skid steer to dump the load.

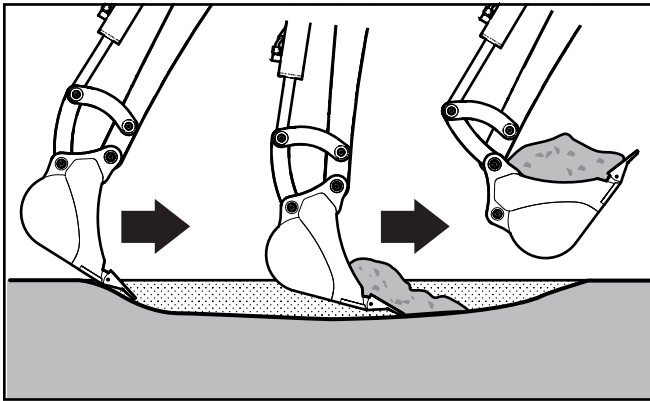

Fig. 7—Dig with the boom

Dig with the Bucket

1. Use the loader-arm plate to set the bucket angle for digging at approximately 30 degrees to the ground.
2. Use the loader-arm plate and boom to push the bucket into the ground, while you curl the bucket backward to fill it.
3. Raise the boom, and then rotate the skid steer to dump the bucket.
4. Continue to dig 3–6 in (75–150 mm) deeper each time.

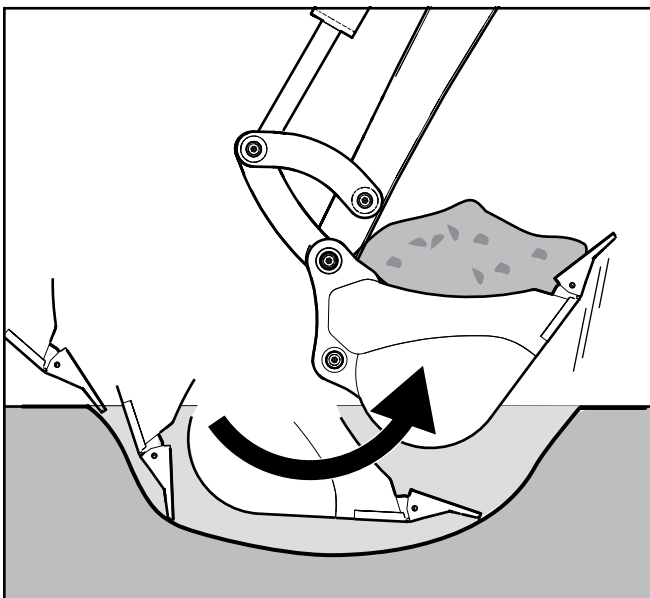

Fig. 8—Dig with the bucket

7.5.2 Dig a Trench

1. Mark the excavation area.
2. Use the boom or bucket method to dig.
3. Make the first dig shallow and accurate. The first dig keeps the next digs accurate and the trench straight.

7.5.3 Fill Holes

Use the bucket to push or pull dirt into a hole or trench.

Pull dirt into a hole or trench:

1. Position the bucket behind the dirt pile with the hole or trench in front. Make sure the skid steer does not get too close to the excavation.
2. Lower the bucket close to the ground.
3. Drive the skid steer backward to pull the material into the hole or trench.

Push dirt into a hole or trench:

1. Position the bucket in front of the dirt pile with the hole or trench behind.
2. Lower the bucket close to the ground with the back of the bucket facing the dirt pile.
3. Drive the skid steer forward to push the material into the trench or hole.

7.6 Stop and Park

Take care when exiting a skid steer. Use three points of contact and only step on non-slip surfaces.

1. Stop the skid steer on dry, level ground.
2. Lower the skid digger bucket to the ground.
3. Apply the parking brake.
4. Idle the skid steer engine for five minutes to cool it.
5. Turn OFF the hydraulic circuit.
6. Turn OFF the skid steer engine and remove the key.

7.7 Stop in an Emergency

Be familiar with the controls for your skid steer. Know how to stop the engine and attachment quickly in an emergency.

1. Immediately release the hydraulic controls to neutral to stop movement.
2. Apply the parking brake.
3. Turn OFF the skid steer.
4. Evaluate the situation to determine the safest way to proceed.

7.8 Transport

IMPORTANT! Equipment that is transported on a public roadway must comply with the local laws that govern the safety and transport of machinery.

The skid digger is not intended for use or transport on public roadways.

For specific skid steer requirements, contact your local transportation authority.

Read and follow the transport instructions provided by the skid steer manufacturer.

7.8.1 Transport Safety

- Never allow any person to ride on the skid digger or skid steer.
- Do not exceed a safe travel speed. Slow down for rough terrain and cornering.
- Stay clear of ditches and excavations to avoid a tip over.
- Turn into curves or go up or down hills only at a low speed with a gradual steering angle.
- Make sure the skid digger is securely attached to the skid steer and all the lock pins have retainers installed.
- Warn and stay clear of other people.
- Avoid abrupt starts, stops, and turns.

7.8.2 Prepare for Transport

1. Fully extend the bucket straight ahead of the skid steer.
2. Remove all mud, debris, and entangled material.
3. Lower the skid digger until it is close to the ground for stability and visibility.

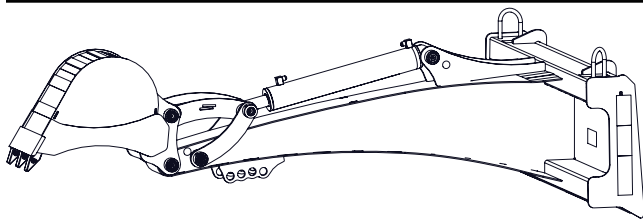

Fig. 9 – Transport position

7.9 Storage

When the skid digger will not be used for an extended length of time, disconnect it from the skid steer and place it in storage. Repair or replace any worn or damaged components to prevent any unnecessary down time at next use.

- Store the skid digger in an area away from human activity. Select an area that is dry, level, and free of debris.
- Do not allow children to play on or around stored equipment.

7.10 Place in Storage

1. Thoroughly wash the skid digger using a pressure washer to remove all dirt, mud, and debris.
2. Remove the skid digger from the skid steer. For instructions, see *Remove from a Skid Steer on page 20*. Place blocks or planks under the base and bucket.
3. Inspect the bucket and boom for damage or entangled material. Repair or replace damaged parts. Remove all entangled material.
4. Lubricate all grease fittings. Make sure all grease cavities have been filled with grease to remove any water residue from washing.
5. Touch up all paint nicks and scratches to prevent rusting. Replace any damaged safety signs.
6. Apply a coat of heavy grease to exposed cylinder rams to prevent rusting.
7. If the skid digger cannot be stored inside, cover it with a waterproof tarp.

7.11 Remove from Storage

1. Remove the grease or protective coating from the cylinder rod.
2. Attach the skid digger to a skid steer. For instructions, see *Attach to a Skid Steer on page 19*.
3. Complete the tasks described in the *Pre-operation Checklist on page 22*.

8. Service and Maintenance

CAUTION!

Do not risk injury by working in an unsafe situation. Take steps to make the machine safe to work on before performing any maintenance or service procedure.

Follow steps listed to put the machine in a Safe Condition.

W049

Safe Condition

1. Rest the bucket on the ground.
2. Turn off the hydraulic system.
3. Apply the parking brake.
4. Turn off the skid steer engine and remove the ignition key.
5. Activate the hydraulic controls to relieve the pressure.
6. Make sure all components have stopped moving.
7. Block or chock the skid steer wheels.

8.1 Maintenance Safety

- Read and understand all the information in the Safety section that starts on *page 7*.
- Have a minimum of two workers present when performing maintenance on this equipment. Never work alone in case an emergency should arise.
- Follow good shop practices that include, but are not limited to the following:
 - Keep the service area clean and dry.
 - Ground electrical outlets and tools correctly.
 - Make sure that there is an adequate amount of light for the current task.
- Never operate the tractor in a closed building. The exhaust fumes may cause asphyxiation.
- Never work underneath equipment unless it is securely supported by blocks.
- Always wear the appropriate PPE.
- When replacement parts are required, only use genuine original equipment manufacturer (OEM) parts. Wallenstein Equipment cannot be held responsible for damage or injuries that are caused by use of unapproved parts or accessories.
- Inspect and tighten all bolts, nuts, and screws.

- Reinstall all safety shields and covers after completing service or maintenance.
- Use regular cleaners to clean parts. Do not use gasoline.
- Always use the correct tools for the task, make sure that the tools are in good condition, and understand how to use them.

8.1.1 Hydraulic System Safety

- Make sure that all the components in the hydraulic system are kept clean and in good condition.
- Make sure all components are tight, and that lines, hoses and couplings are not damaged before applying pressure to the system.
- Do not use your hand to check for hydraulic oil leaks. Hydraulic fluid escaping under pressure can penetrate the skin causing serious injury. Use a piece of cardboard instead.
- Wear proper hand and eye protection when searching for a high-pressure hydraulic leak.

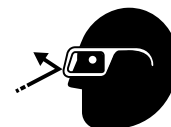

- Seek medical attention immediately if injured by a concentrated high-pressure stream of hydraulic fluid. Serious infection or toxic reaction can develop from hydraulic fluid piercing the skin surface.
- Do not attempt any makeshift repairs to the hydraulic lines, fittings, or hoses by using tape, clamps, or cements. Doing so can cause sudden failure and create a hazardous and unsafe condition.
- Relieve pressure on the hydraulic system before working it. The hydraulic system operates under extremely high pressure.
- Replace any hydraulic hose immediately that shows signs of swelling, wear, leaks, or damage before it bursts.
- Do not bend or strike high-pressure lines, tubes or hoses, or reinstall them in a bent or damaged condition.
- Check to make sure hydraulic hoses are not worn or damaged and are routed to avoid chafing.
- Never adjust a pressure relief valve or other pressure-limiting device to a higher pressure than specified.

8.2 Maintenance Schedule

Perform maintenance procedures at time shown or hour interval, whichever comes first.

As Required Maintenance	
Remove any entangled material.	

Every 8 hours of operation or daily	
Grease the skid digger.	See page 27.
Check that all fasteners are tight.	See page 31.
Check the condition of all hydraulic lines, hoses, and fittings. Replace any that are damaged. Reroute those that are rubbing, pinched, or crimped. Tighten any fitting that is leaking. Ensure fittings are clean and free of dirt.	See page 32.

Every 50 hours of operation or weekly	
Check condition of bucket teeth. Replace, if required.	See page 28.

Every 100 hours of operation or annually	
Clean—remove any entangled material or debris build-up.	

8.3 Grease Points

Look for this decal on the skid digger. It indicates a grease point and the number of hours between greasing.

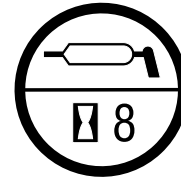

For the grease point locations, see the following image (Fig. 10—Grease points on page 27). Look for the following symbol, which indicates the number of grease points at each location.

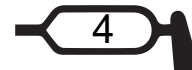

Use an SAE multi-purpose high temperature grease with extreme pressure (EP) performance. Also acceptable is an SAE multipurpose lithium-based grease.

Grease the skid digger regularly to keep it working efficiently and extend its life.

- Use a hand-held grease gun. Typically, two applications per fitting is enough; however, pump grease until it is visible at the joint.
- Wipe off grease fittings with a clean cloth before greasing to avoid injecting dirt and grit.
- If fittings do not take grease, remove, and clean them thoroughly. Replace grease fittings, as required.
- Immediately replace or repair grease fittings that are not working correctly.

Always grease the skid digger after pressure-washing it.

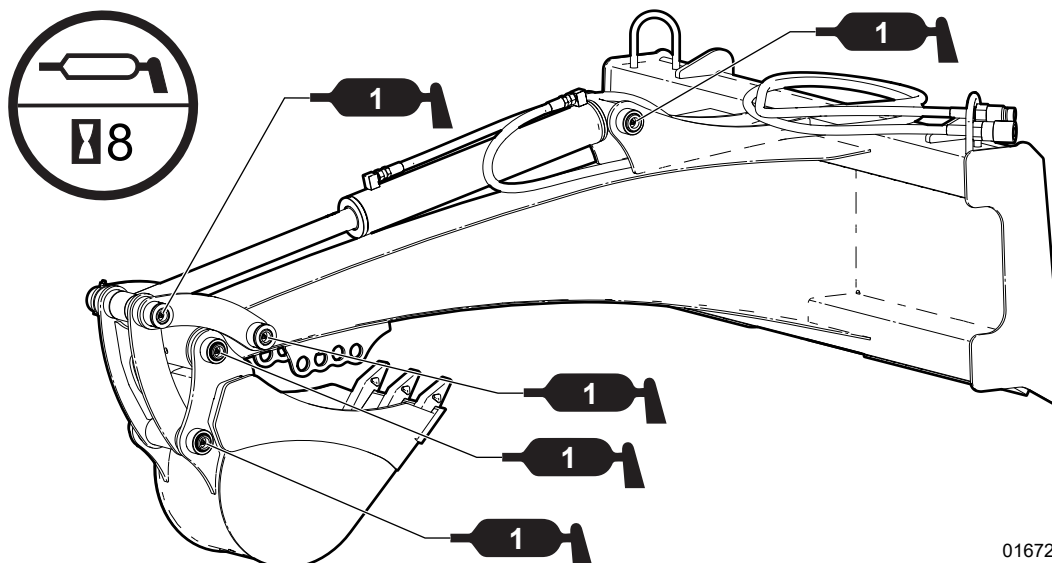

Fig. 10—Grease points

8.4 Replace a Bucket Tooth

Check bucket teeth condition weekly. Replace if bent, damaged, or worn out.

1. Bucket teeth are held in place with a roll pin (1). Drive out the roll pin to remove the tooth (2).
2. Clean the shank (3) with a wire brush.
3. Install the new tooth as shown, then drive the roll pin back in to hold it on.

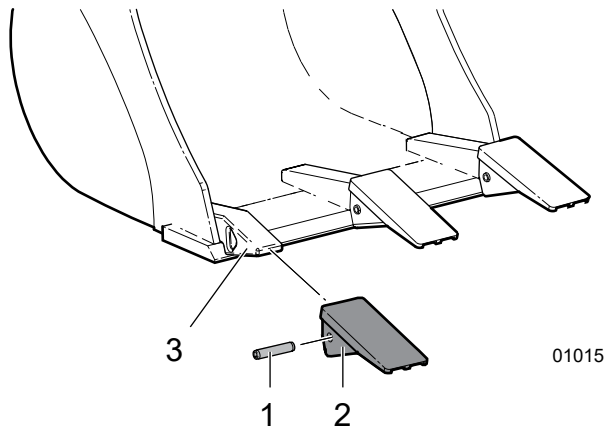

Fig. 11 – Replace a bucket tooth

1. Roll pin
2. Tooth
3. Tooth shank

8.5 Remove the Bucket

If changing to a different accessory or size of bucket, support the boom so that the bucket is resting on the ground. Make sure the boom cannot move unexpectedly when the pins are driven out.

1. Remove retaining bolts and nuts that secure the pins.
2. Carefully drive the pins out. If the pins do not move, shift the boom, link, or bucket (be careful that the bucket doesn't drop). Do not pound hard on the end of the pin. It could mushroom and become stuck.
3. Remove the bucket and position the new attachment in place.
4. Clean and lightly grease the pins.
5. Insert the pins and carefully drive them in. Adjust the position of the boom or link as required.
6. Install the retaining bolts and nuts.
7. Lubricate both pins through the grease fitting on the end before putting the skid digger into operation.

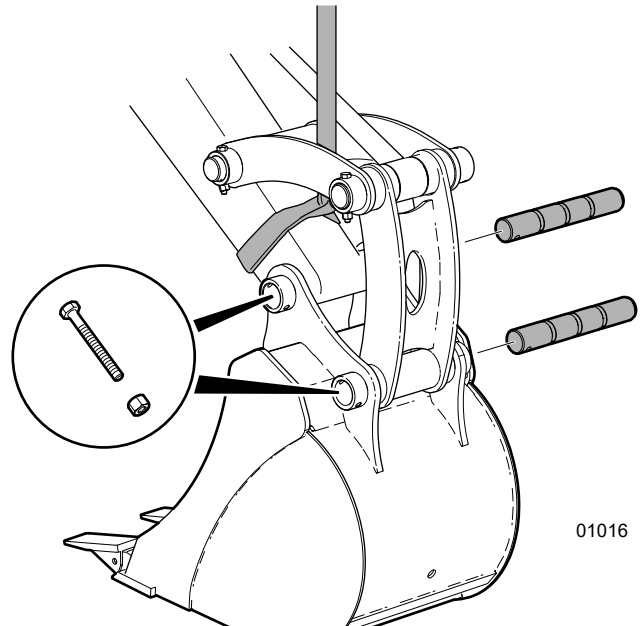

Fig. 12 – Remove the bucket

9. Troubleshooting Guide

If a problem is encountered that is difficult to solve, even after having read through this troubleshooting section, contact your local dealer, distributor, or Wallenstein Equipment.

Have the serial number for your skid digger available. See the *Serial Number Location on page 5*.

Problem	Cause	Solution
Cylinder rods do not move or move slowly.	No pressurized hydraulic oil.	Oil filter plugged. Change filter. Low hydraulic oil level. Add oil to reservoir.
	Pressure and return hoses to the skid digger are reversed.	Change hose connections.
	Not enough oil flow.	Flow control set too low. Adjust for more flow.
	Stuck / damaged / mismatched couplers.	Clean or replace couplers. Make sure mating couplers are same style.
	Check valve stuck.	Clean or replace.
	Engine speed too slow.	Increase engine speed to correct rpm.
Cylinder movements jerky.	Hydraulic system leak. Air in hydraulic system.	Tighten all hydraulic connections. Cycle cylinders to remove air.
Control handle does not go to neutral when released.	Return springs collapsed.	Check and replace if required.
	Control valve may be damaged.	Call technician. Valve may need to be serviced or replaced.
Hydraulic hose leaking.	Hose worn or damaged.	Replace hose. Check hose routing to avoid chafing or rubbing.
	Loose hose connection. Adapters or hose ends damaged.	Tighten or replace if damaged.
Cylinder leaking oil.	Seals worn.	Call technician. Seal replacement may be required.
Hydraulic system behaving erratically.	Mismatched control valve. Valve type must be same as tractor hydraulic circuit (open or closed center).	Determine if hydraulic system on tractor is open or closed center. Make sure is same.
Bucket drifts down.	Seals leaking (bypassing).	Replace seals.

10. Specifications

10.1 Equipment Specifications¹

Model	XD600S
Digging depth	6 ft (183 cm)
Skid steer engine HP range	30–65 hp
Required hydraulic flow	3–22 gpm (14–83 Lpm)
Total weight	296 lb (134 kg)
Maximum system pressure	3,000 psi (20,694 kPa)
Mounting System Type	Universal quick-attach plate

10.2 Accessories

Accessory	Description
Nine-inch bucket	Three teeth, 0.8416 cubic ft volume
12-inch bucket	Three teeth, 1.2 cubic ft volume
15-inch bucket	Four teeth, 1.5 cubic ft volume
18-inch bucket	Four teeth, 1.8 cubic ft volume
24-inch bucket	Five teeth, 2.4 cubic ft volume
24-inch ditching bucket	No teeth, 2.4 cubic ft volume
Mechanical thumb	Pin attached mechanical thumb
Quick-change bucket adapter	Quickly change to a different bucket. Two greaseable pins for each bucket are required (sold separately).
Greaseable pins	Two required per bucket for use with a quick-change bucket adapter (sold individually).
Ripper tooth	Recommended for breaking up hard ground.

¹ Specifications are subject to change without notice.

10.3 Common Bolt Torque Values

Bolt Torque, Checking

The tables shown give correct torque values for various bolts and capscrews. Tighten all bolts to the torque values specified in the table, unless indicated otherwise. Check tightness of bolts periodically.

IMPORTANT! If replacing hardware, use fasteners of the same grade.

IMPORTANT! Torque figures indicated in the table are for non-greased or non-oiled threads. Do not grease or oil threads unless indicated otherwise. When using a thread locker, increase torque values by 5%.



Bolt grades are identified by their head markings.

Imperial Bolt Torque Specifications						
Bolt Diameter	Torque Value					
	SAE Gr. 2		SAE Gr. 5		SAE Gr. 8	
	lbf•ft	N•m	lbf•ft	N•m	lbf•ft	N•m
1/4"	6	8	9	12	12	17
5/16"	10	13	19	25	27	36
3/8"	20	27	33	45	45	63
7/16"	30	41	53	72	75	100
1/2"	45	61	80	110	115	155
9/16"	60	95	115	155	165	220
5/8"	95	128	160	215	220	305
3/4"	165	225	290	390	400	540
7/8"	170	230	420	570	650	880
1"	225	345	630	850	970	1320



SAE Gr. 2



SAE Gr. 5



SAE Gr. 8

Metric Bolt Torque Specifications				
Bolt Diameter	Torque Value			
	Gr. 8.8		Gr. 10.9	
	lbf•ft	N•m	lbf•ft	N•m
M3	0.4	0.5	1.3	1.8
M4	2.2	3	3.3	4.5
M6	7	10	11	15
M8	18	25	26	35
M10	37	50	52	70
M12	66	90	92	125
M14	83	112	116	158
M16	166	225	229	310
M20	321	435	450	610
M30	1,103	1 495	1,550	2 100



8.8



10.9

10.4 Hydraulic Fitting Torque Values

Tightening Flare Type Tube Fittings

1. Check flare and flare seat for defects that might cause leakage.
2. Align tube with fitting before tightening.
3. Hand-tighten swivel nut until snug.
4. To prevent twisting the tube, use two wrenches. Place one wrench on the connector body and tighten the swivel nut with the second. Torque to values shown.

If a torque wrench is not available, use the FFFT (Flats From Finger Tight) method.

Hydraulic Fitting Torque							
Tube Size OD	Hex Size Across Flats	Torque value		Flats From Finger Tight			
		Inches	Inches	lbf•ft	N•m	Flats	Turns
3/16	7/16			6	8	2	1/6
1/4	9/16			11–12	15–17	2	1/6
5/16	5/8			14–16	19–22	2	1/6
3/8	11/16			20–22	27–30	1-1/4	1/6
1/2	7/8			44–48	59–65	1	1/6
5/8	1			50–58	68–79	1	1/6
3/4	1-1/4			79–88	107–119	1	1/8
1	1-5/8			117–125	158–170	1	1/8

Values shown are for non-lubricated connections.

11. Product Warranty



LIMITED WARRANTY

Wallenstein products are warranted to be free of defects in materials and workmanship under normal use and service, for a period of

Five Years for Consumer Use

Two Years for Commercial/Rental Use

from the date of purchase, when operated and maintained in accordance with the operating and maintenance instructions supplied with the unit. Warranty is limited to the repair of the product and/or replacement of parts.

This warranty is extended only to the original purchaser and is not transferable.

Repairs must be done by an authorized dealer. Products will be returned to the dealer at the customer's expense. Include the original purchase receipt with any claim.

This warranty does not cover the following:

- 1) Normal maintenance or adjustments
- 2) Normal replacement of wearable and service parts
- 3) Consequential damage, indirect damage, or loss of profits
- 4) Damages resulting from:
 - Misuse, negligence, accident, theft or fire
 - Use of improper or insufficient fuel, fluids or lubricants
 - Use of parts or aftermarket accessories other than genuine Wallenstein parts
 - Modifications, alteration, tampering or improper repair performed by parties other than an authorized dealer
 - Any device or accessories installed by parties other than an authorized dealer
- 5) Engines. Engines are covered by the manufacturer of the engine for the warranty period they specify. For the details of your engine warranty, see your engine owner's manual. Information about engine warranty and service is also available in the FAQ section at www.wallensteinequipment.com

12. Index

	A			M
Accessories.....		30	Maintenance Decals.....	6
Attach to a Skid Steer.....		19	Maintenance Safety.....	10, 26
	B		Maintenance Schedule.....	27
Before Startup.....		22	As required.....	27
Bolt torque.....		31	Every 8 hours or daily.....	27
Bolt Torque, Checking.....		31	Every 50 hours or weekly.....	27
Bucket			Every 100 hours or annually.....	27
Remove.....		28		O
Replace a Tooth.....		28	Operating Safety.....	9
	C		Operation.....	22
Controls.....		21	Before Startup.....	22
	D		Digging.....	23
Designated Safe Area.....		11	Machine Break-in.....	23
Digging.....		23	Pre-operation Checklist.....	22
Dig a Trench.....		24	Safe Operating Techniques.....	23
Dig with the Boom.....		24	Stop and Park.....	24
Dig with the Bucket.....		24	Stop in an Emergency.....	24
Fill Holes.....		24	Storage.....	25
	E		Transport.....	25
Equipment Matching.....		19	Work Site Safety.....	22
Equipment Specifications.....		30	Operator Orientation.....	17
	F			P
Familiarization.....		17	Place in Storage.....	25
Operator Orientation.....		17	Pre-operation Checklist.....	22
Skid Digger Components.....		18	Product Labels.....	6
To the New Operator.....		17		R
Training.....		17	Remove from a Skid Steer.....	20
Fill Holes.....		24	Remove the Bucket.....	28
Foreword			Replace a Bucket Tooth.....	28
Delivery Inspection Report.....		4	Replacing Damaged Safety Signs.....	16
Types of Decals on the Machine.....		6		S
	G		Safe Operating Techniques.....	23
Grease Points.....		27	Safety.....	7
	H		Equipment Guidelines.....	8
Hydraulic			Hydraulic System Safety.....	10
Fitting Torque Values.....		32	Maintenance Safety.....	10
System Safety.....		10, 26	Operating Safety.....	9
	I		Safety Alert Symbol.....	7
Informative Labels.....		6	Safe Zone.....	11
Installation.....		19	Set Up a Work Zone.....	11
Attach to a Skid Steer.....		19	Signal Words.....	7
Equipment Matching.....		19	Sign-Off Form.....	13
Remove from a Skid Steer.....		20	Training.....	9
	L		Why Safety is Important.....	7
Lifting Objects.....		22	Safety Alert Symbol.....	7
			Safety Notice Labels.....	6
			Safety Rules.....	8
			Safety Signs	
			Replacing Damaged Safety Signs.....	16
			Safety Sign Explanations.....	15
			Safety Sign Locations.....	14

Safe Zone.....	11
Serial Number Location.....	5
Service and Maintenance.....	26
Grease Points.....	27
Hydraulic System Safety.....	26
Maintenance Safety.....	26
Maintenance Schedule.....	27
Remove the Bucket.....	28
Replace a Bucket Tooth.....	28
Set Up a Work Zone.....	11
Skid Digger Components.....	18
Skid steer	
Attachment weight.....	19
Horsepower.....	19
Hydraulic system.....	19
Specifications.....	30
Accessories.....	30
Common Bolt Torque Values.....	31
Equipment Specifications.....	30
Hydraulic Fitting Torque.....	32
Stop and Park.....	24
Stop in an Emergency.....	24
Storage	
Place in Storage.....	25
Remove from Storage.....	25

T

Transport.....	25
Transport Safety.....	25
Troubleshooting Guide.....	29

W

Work Site Safety.....	22
Work Zone.....	11, 22

WALLENSTEIN