



Heavy Duty Pick-Up Broom

For

Skid Steer Loaders

Operator's Manual
Set-Up Assembly
Maintenance
Parts Information



Read this Manual Before Use

TABLE OF CONTENTS

SAFETY	3-4
SERIAL NUMBER/DECAL LOCATION	5-6
USER'S MOUNTING INSTRUCTIONS	7-8
OPERATING INSTRUCTIONS	9-12
ROUTINE MAINTENANCE	13-16
SET-UP ASSEMBLY	17-28
BOLT TORQUE INFORMATION	29
PARTS INFORMATION	30-37
GENERAL SPECIFICATIONS	38
WARRANTY	39

REFERENCE INFORMATION

Write the serial number for your attachment in the spaces below. Always refer to this serial number when calling for service or parts.

Serial Number....._____

YOUR ATTACHMENT DEALER

ADDRESS: _____

PHONE: _____

CONTACT: _____

NOTE: *Erskine Attachments LLC reserves the right to make improvements in design or changes in specifications at any time without notice and without incurring any obligations to install them on units previously sold.*

SAFETY

DO NOT use or perform maintenance on this machine until this manual has been read and understood. In addition, read the Operation and Maintenance Manual(s) pertaining to the attachment and the attachment carrier (“Loader”).

The user is responsible for inspecting the machine daily, and for having parts repaired or replaced when continued use of the machine would cause damage, excessive wear to other parts or make the machine unsafe for continued operation.

If an operating procedure, tool device, maintenance or work method not specifically recommended is used, you must satisfy yourself that it is safe for you and others. You must also ensure that the attachment will not be damaged or made unsafe by the procedures you choose.

Erskine Attachments LLC cannot anticipate every possible circumstance that might involve potential hazard. The safety messages found in this manual and on the machine are therefore not all inclusive.

Throughout this manual reference may be made to the left hand (LH) or right hand (RH) side. These terms are used as viewed from the operator’s seat facing forward.

The signal words **CAUTION**, **WARNING**, or **DANGER** are used to indicate hazards.

⚠ CAUTION Indicates a potentially hazardous situation which, if not avoided, may result in minor or moderate injury.

⚠ WARNING Indicates a potentially hazardous situation which, if not avoided, could result in death or serious injury.

⚠ DANGER Indicates a potentially hazardous situation which, if not avoided, will result in death or serious injury.

The word **IMPORTANT** is used in the text when immediate damage will occur due to improper technique or operation.

The word **NOTE** is used to convey information that is out of context with the manual text; special information such as specifications, techniques, reference information, and other information of a supplementary nature.

Improper operation can cause serious injury or death.

Pre-operation

- This machine is designed for sweeping dirt and small debris from hard surfaces only. **NEVER** use this machine for any other purpose.
- Read the operator's manual for the "Skid Steer Loader." **NEVER** allow untrained people to operate.
- Operating instructions must be given to everyone before operating this attachment and at least once a year thereafter in accordance with OSHA regulations.
- **NEVER** exceed the maximum recommended input power or speed specifications for the attachment. Over-powering or over-speeding the attachment may cause personal injury and/or machine damage.
- Keep all shields, guards, and covers in place.
- Do not modify equipment or add attachments that are not approved by Erskine Attachments LLC.
- Use adequate safety warning lights and devices as required by local regulations. Obey all local laws and regulations regarding machine operation on public property.

Operation

- Always wear eye protection that meets ANSI z87.1 standard or use with a loader enclosure that provides similar protection.
- Hydraulic connections may be hot after use. Use gloves if connecting or disconnecting after use.
- Check and be sure all operating controls are in neutral before starting the engine.
- Keep people away from loader, attachment and discharge when in use. This attachment sends objects flying and has rotating parts. **NEVER** direct discharge toward people – rocks and debris can be thrown.
- Depending on how this attachment is used, dust can be created. Prolonged exposure to dust can cause chronic and acute health problems. A NIOSH-approved respirator may be required.

Operation (continued)

- **NEVER** operate near embankments or terrain that is so steep that rollover could occur.
- Always stay in the operator position when using the attachment.
- Before leaving the operators position, disengage hydraulic drive, lower the attachment to rest flat on the ground, stop engine, set park brake, and wait for all motion to stop.
- **NEVER** place hands in the discharge area or clear debris while engine is running.

Avoid High Pressure Fluids Hazard



- Escaping fluid under pressure can penetrate the skin causing serious injury.
- Avoid the hazard by relieving the pressure before disconnecting hydraulic lines.
- Use a piece of paper or cardboard, NOT BODY PARTS, to check for suspected leaks. Wear protective gloves and safety glasses or goggles when servicing or performing maintenance on hydraulic systems.
- If an accident occurs, see a doctor immediately. Any fluid injected into the skin must be surgically removed within a few hours or gangrene may result.

Maintenance

- **NEVER** make adjustments, lubricate, clean, or perform any service on the machine while it is in operation.
- Make sure the attachment is serviced on a daily basis. Improper maintenance can cause serious injury or death in addition to damage to the attachment and/or your equipment.

SERIAL NUMBER AND SAFETY DECAL LOCATIONS

Serial Number Location:

It is important to refer to the serial number of the attachment when making repairs or ordering parts. Early or later models (identification made by serial number) may use different parts, or it may be necessary to use different procedures in doing a specific operation.

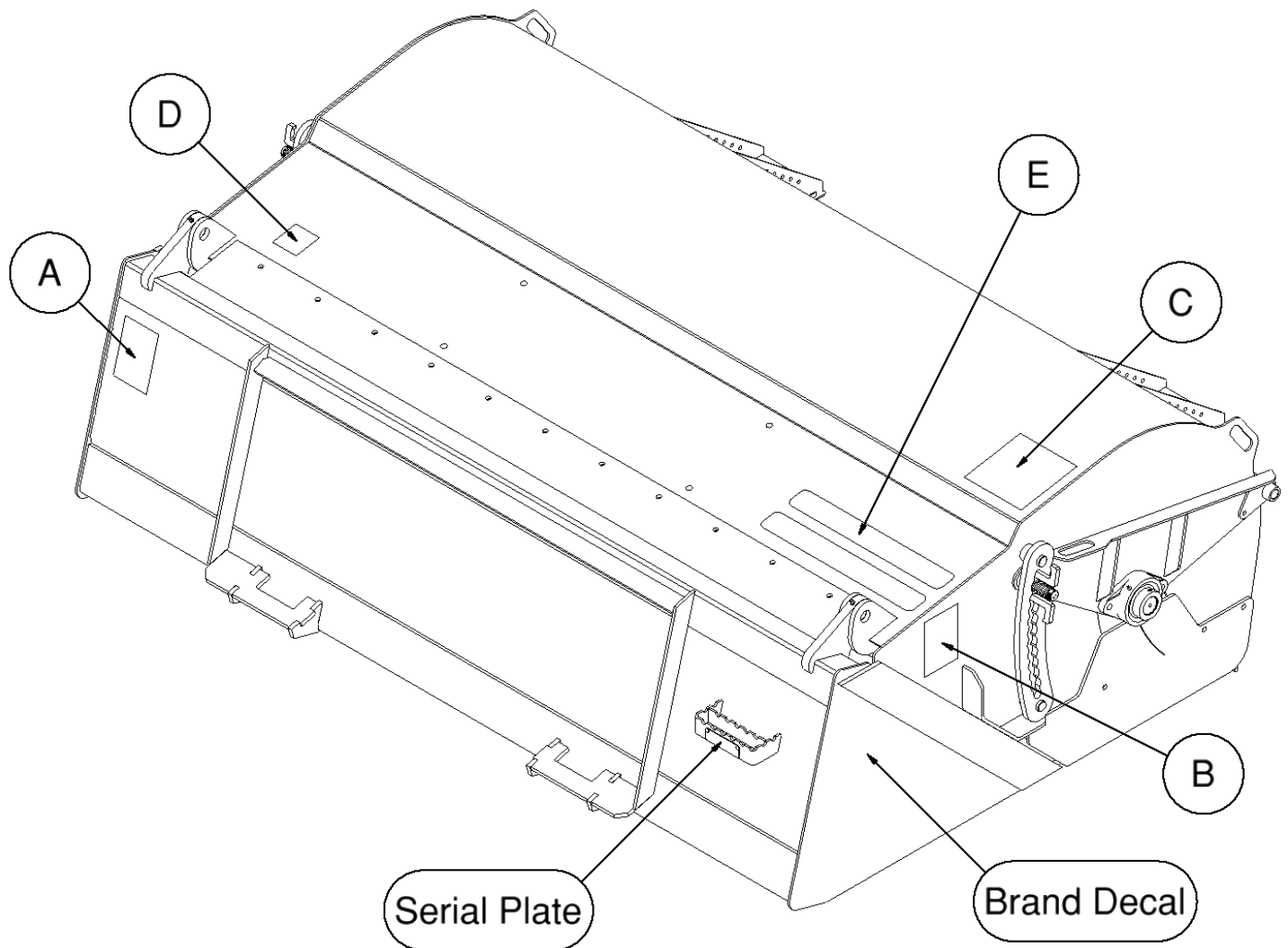

SERIAL NUMBER AND SAFETY DECAL LOCATIONS



Part number: 200001

Location: On back of bucket, left side

Quantity: 1



Part number: 203234

Location: On each side of broom near pivot

Quantity: 2

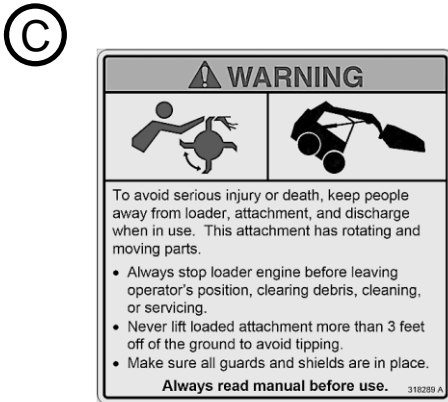

Part number: 318289

Location: On top of hood, right side

Quantity: 1

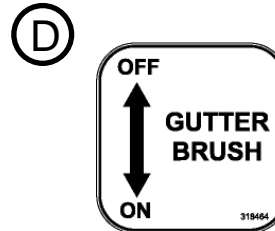

Part number: 318464

Location: On top of hood, next to opt. valve

Quantity: 1 (w/ Optional Curb Sweeper)

E

Part number: 202153 (Anti-skid tape 2x16)

Location: On top of hood, right side

Quantity: 2

Small Brand Decal

Location: On each side of bucket

Quantity: 2

Safety Decals Locations:

The locations of the safety decals are shown. If these decals are missing, damaged, or painted over they must be replaced. Call Erskine Attachments LLC (218-435-4045) for replacement decals.

USER'S MOUNTING INSTRUCTIONS

After the initial set-up assembly is completed use the following procedure to mount the attachment to the loader.

⚠ WARNING Levers must be fully down and locked. Failure to secure wedges or pins can allow the attachment to come off and cause injury or death.



1. Use the step, safety treads, and grab handles to get on and off the loader and attachment.

2. Sitting in the operator's seat, lower seat bar (if so equipped) and fasten the seat belt.

3. Drive the loader to the rear of the attachment. Put the loader quick attach coupler into the attachment mounting bracket.

4. Tilt the loader coupler backward a small amount until it is fully engaged in the attachment mounting bracket.

5. Stop the engine and engage the park brake.

6. Secure the coupler locking mechanism that attaches the attachment to the loader.

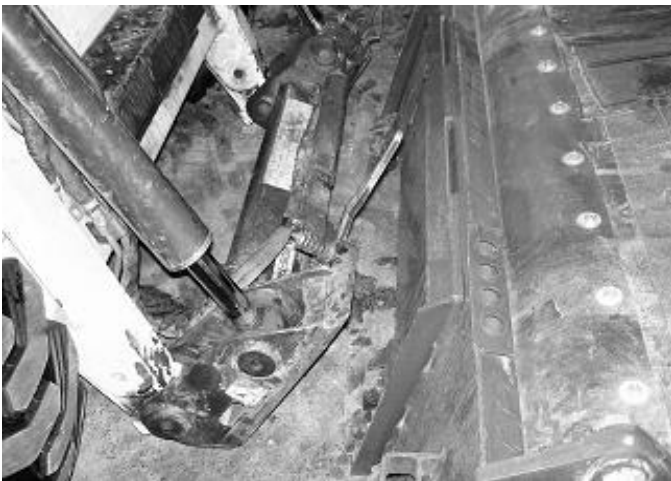

USER'S MOUNTING INSTRUCTIONS

7. Connect the hydraulic quick couplers from the attachment to the loader.

IMPORTANT: Wipe the ends of the hydraulic quick couplers (both lead and loader) with a rag to remove any possible contamination. Contamination can cause hydraulic components to fail and is not covered under warranty.

IMPORTANT: Make sure the quick couplers are fully engaged. If the quick couplers do not fully engage, check to see that the couplers are the same size and brand. Do not force the quick couplers together.

NOTE: See the loader's operator's manual for auxiliary hydraulic specifications and connection instructions.

NOTE: Attachment is shipped with 12FJX (1-1/16" Female JIC Swivel) fittings on the ends of the lead hoses.

8. Make sure the hoses are properly routed to fit your specific loader. If the hoses are not routed correctly, hoses may get pinched or rub on tires. Be sure to check the hose routing through the full range of intended motion of the attachment before operating it.

More than one routing may be acceptable depending on the loader. Pick the routing that best suits your loader.

IMPORTANT: Proper hose routing is the responsibility of the owner and/or operator. Pinched or stretched hoses are not covered under warranty.

Mounting is now complete and the attachment is ready for operation. Use reverse order of above instructions to dismount the attachment from the loader.

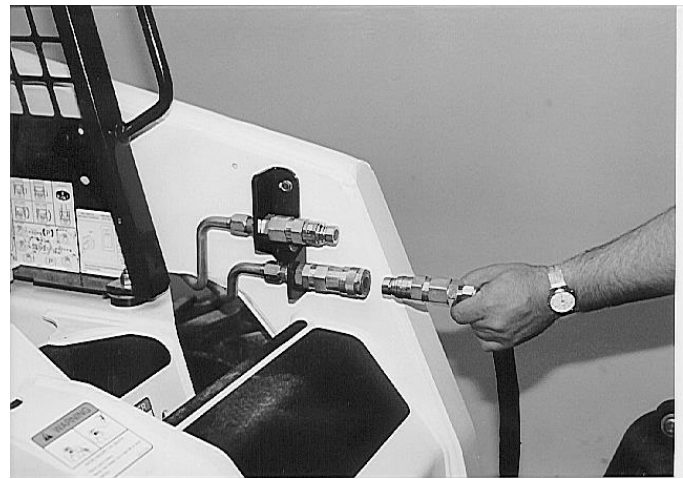

OPERATING INSTRUCTIONS

1. With the operator in the seat of the loader, the seatbelt fastened, and the seat bar lowered (if so equipped), start the engine.

2. Position the attachment so that the bucket is slightly off of the ground, and the broom assembly wheel is resting on the ground.

IMPORTANT: Excessive down pressure will cause premature bristle wear or breakage.

NOTE: The down pressure on the broom determines the broom contact area on the surface, or the length of bristle contact with the surface. It is recommended to maintain a 2" to 4" bristle contact area while sweeping.

3. At low engine **idle** speed, activate the loader's auxiliary hydraulics in continuous flow mode to start the broom bristles turning.

IMPORTANT: To prevent hydraulic motor damage, always reduce engine speed to idle when engaging and disengaging auxiliary hydraulic flow.

4. Gradually increase engine speed until operating rpm is reached.

IMPORTANT: When making sharp turns, raise the front wheel of the attachment off of the ground slightly to avoid damage to the caster assemblies.

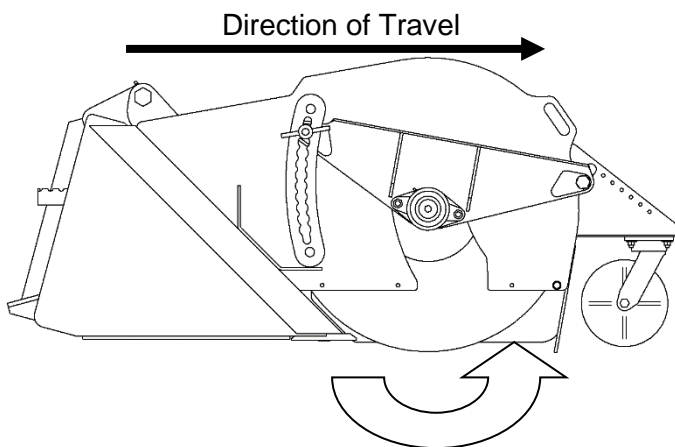
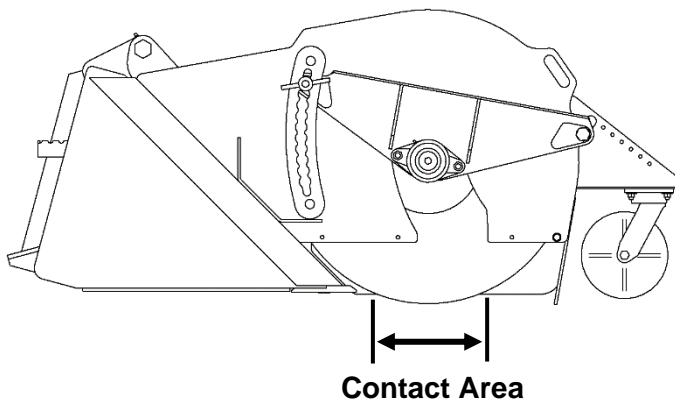

Forward Travel

For normal sweeping, position the bucket cutting edge slightly above the ground (this helps avoid scratching of the surface being swept), activate the auxiliary hydraulics so that the bristles sweep away from the operator (as shown), and slowly drive the loader forward.

OPERATING INSTRUCTIONS

Backwards Travel

If the debris is packed onto the surface being swept, or to pick up larger/heavier material, position the bucket with the cutting edge flat on the ground, activate the hydraulics so that the bristles sweep toward the operator (as shown), and slowly drive the loader backwards.

IMPORTANT: If the pick-up broom is equipped with the optional curb sweeper, make sure the curb sweeper arm has been secured in the up position. The curb sweeper is not designed to be used in the reverse direction. Doing so may result in damage to the curb sweeper.

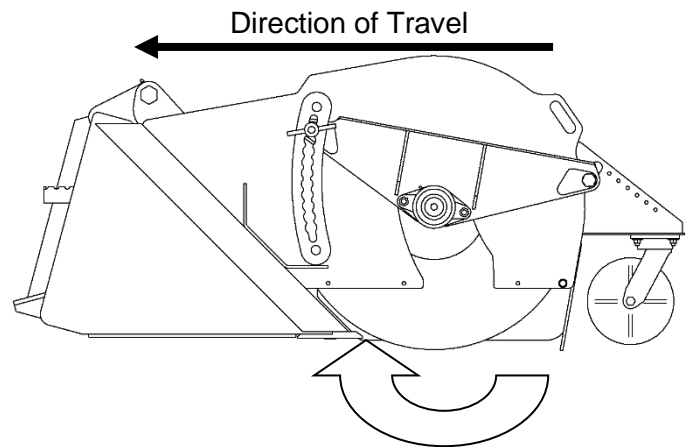

Dumping the Bucket

1. When debris starts falling out of the bucket back onto the surface, this is an indication that the bucket is full and needs to be dumped.
2. Reduce engine speed to idle, disengage the hydraulic drive, raise the attachment slightly off the ground, and drive the loader to the desired dumping area.

⚠ WARNING To avoid serious injury or death due to tip-over, carry attachment as low as possible while transporting.

3. Raise the loader lift arms and tip the attachment forward in order to empty the bucket of debris.

⚠ WARNING To avoid serious injury or death due to tip-over, NEVER lift loaded attachment more than 3 feet off of the ground.

4. Lower the attachment and resume sweeping operation.



OPERATING INSTRUCTIONS

Operating the Optional Curb Sweeper

1. With the loader engine off, the attachment resting flat on the ground, and the park brake set, remove the holding pin from the curb sweeper arm.

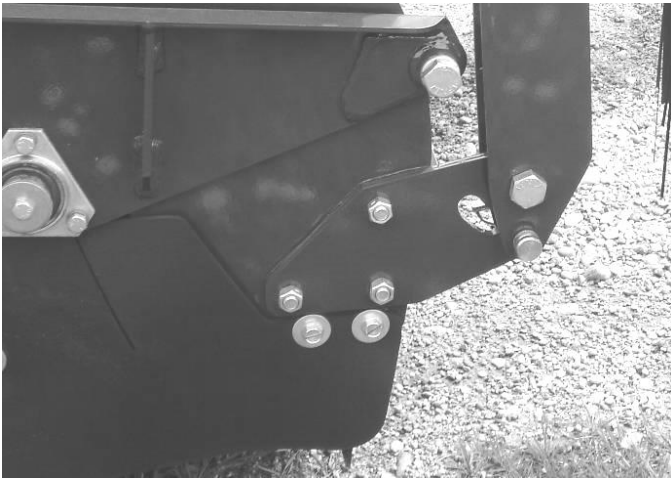

2. Holding onto the handle on the curb sweeper arm, slowly lower the curb sweeper to rest on the ground and install the pin in the floating position.



3. Pull the knob on the valve out to allow oil to flow to the curb sweeper hydraulic motor.

IMPORTANT: Always disengage the auxiliary hydraulics before attempting to shift the manual valve. Failing to do so can damage the valve.

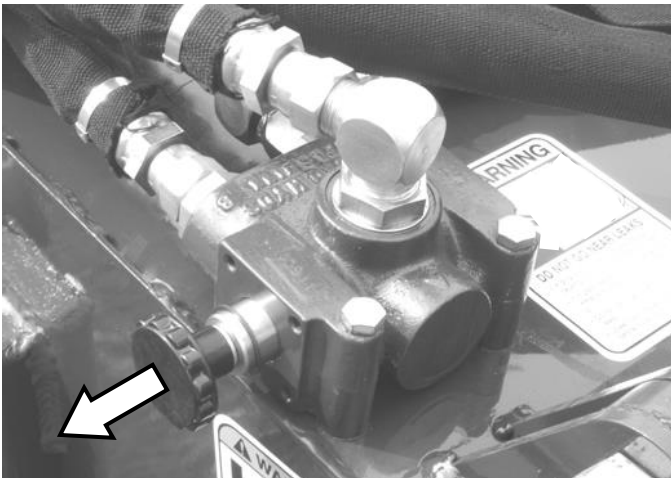

OPERATING INSTRUCTIONS

4. With the operator in the seat of the loader, seat bar lowered (if so equipped), and seat belt fastened, start the loader engine.
5. At low engine idle speed, activate the auxiliary hydraulics to start the broom bristled turning away from the operator. The curb sweeper will also start turning.
6. Gradually increase engine rpm to operating speed, and slowly drive the loader forward to begin sweeping.

IMPORTANT: When sweeping next to curbs, be sure that only the bristles on the curb brush touch any vertical surfaces.

IMPORTANT: The curb sweeper is only designed to be used while travelling in the forward direction. Operating the curb sweeper while travelling in the reverse direction can damage the curb sweeper.



To disengage the curb sweeper:

1. At low engine idle speed, disengage the hydraulic drive, lower the attachment to rest flat on the ground, shut down the engine, engage the park brake, and wait for all motion to stop.
2. Push the knob on the valve in to stop oil flow to the curb sweeper motor.

IMPORTANT: Always disengage the auxiliary hydraulics before attempting to shift the manual valve. Failing to do so can damage the valve.

3. Remove the pin from the floating position, use the handle to lift the curb sweeper arm up to the storage position, and reinstall the pin to lock the curb sweeper arm up in place.

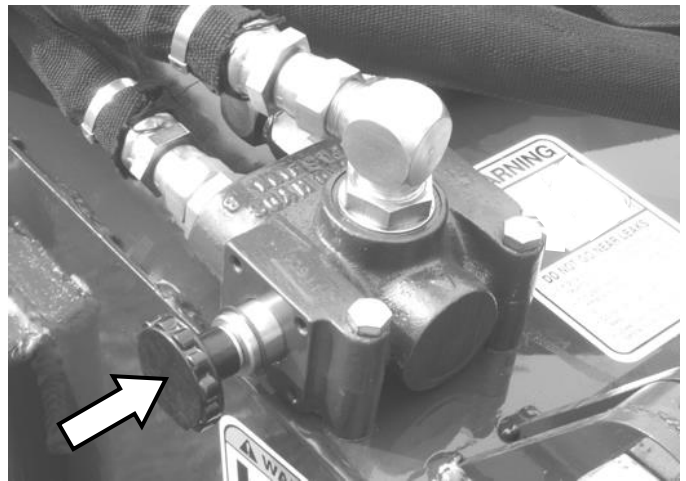





ROUTINE MAINTENANCE

⚠ WARNING Lower the attachment to rest flat on the ground, disengage the hydraulic drive, shut down the engine, relieve the hydraulic pressure to the attachment, set the park brake, and wait for all motion to stop before leaving the operator's seat to perform service of any kind.

It is the operator's responsibility to make daily inspections of the loader and attachment for damage, loose bolts, fluid leaks, or anything else that could cause a potential service or safety problem. Preventive maintenance is the easiest and least expensive type of maintenance.



IMPORTANT: Bolts and set screws can loosen after initial usage. After the first hour of operation check all bolts and set screws.

LUBRICATION

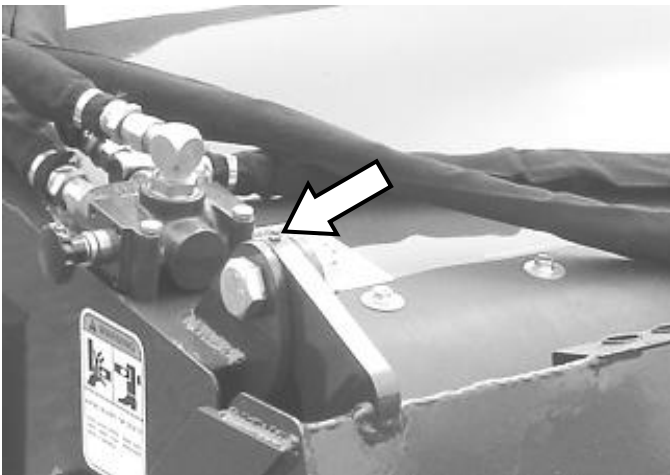
Lubrication Legend	 Multipurpose spray lube	 No. 2 Lithium base gun grease	 Clean engine oil	 Intervals at which lubrication is required
---------------------------	-----------------------------------------------------------------------------------------------------------	-----------------------------------------------------------------------------------------------------------------	-----------------------------------------------------------------------------------------------------	--------------------------------------------------------------------------------------------------------------------------------



Use No. 2 lithium base gun grease when lubricating all attachment grease fittings.

	
-------------------------------------------------------------------------------------	--------------------------------------------------------------------------------------

Grease both pivot ear zerks every **8 hours** of operation.

ROUTINE MAINTENANCE

Replacing Brush Sections

1. Remove the side rubber shields from both sides of the attachment.
2. Remove the two endplate mounting bolts and nuts on each side. Retain for later reassembly.

NOTE: The motor hex drive block will be removed with the endplate.

3. Using a hoist or other suitable lifting method, raise the hood and block it up in place with jack stands.

4. Carefully remove the brush head assembly.

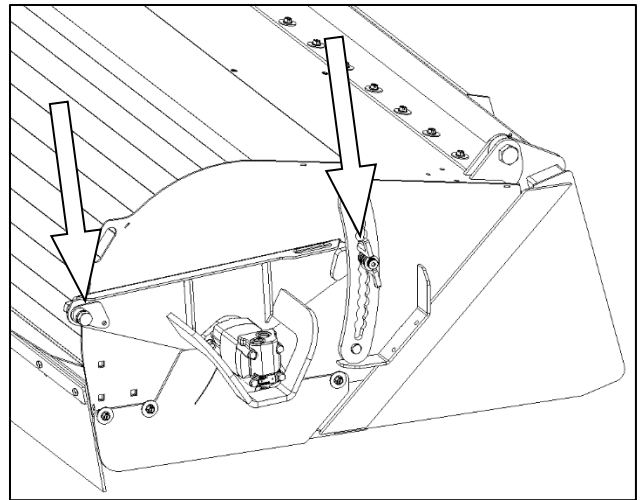

ROUTINE MAINTENANCE

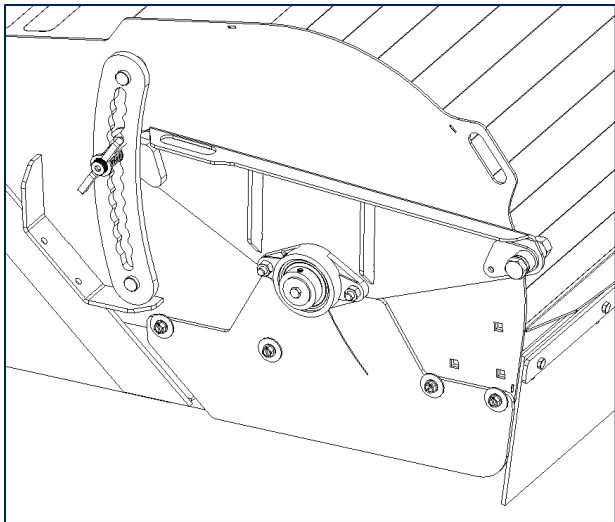

5. Remove the bearing retaining bolt and washer.
6. Loosen the set screw on the bearing collar and slide the bearing and endplate off of the arbor.
7. Remove the three bolts holding the brush retainer to the arbor, and remove the brush retainer.

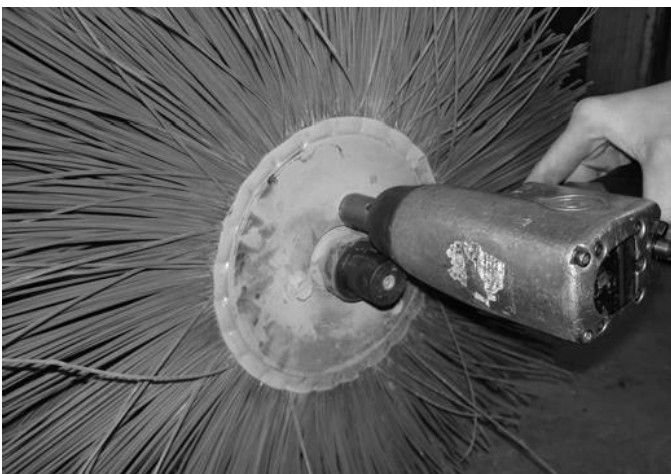

8. Remove the old brush sections.
9. Number the ribs on the arbor as 1, 2, and 3.

10. Slide the first “wavy” brush section on so that the pins are around rib 1.

11. Slide the second “wavy” brush section on so that the pins are around rib 2.

NOTE: Every other brush section will need to be flipped so that the high spots of the bristle “waves” on the neighboring sections hit each other.

12. Slide the third “wavy” brush section on so that the pins are around rib 3.

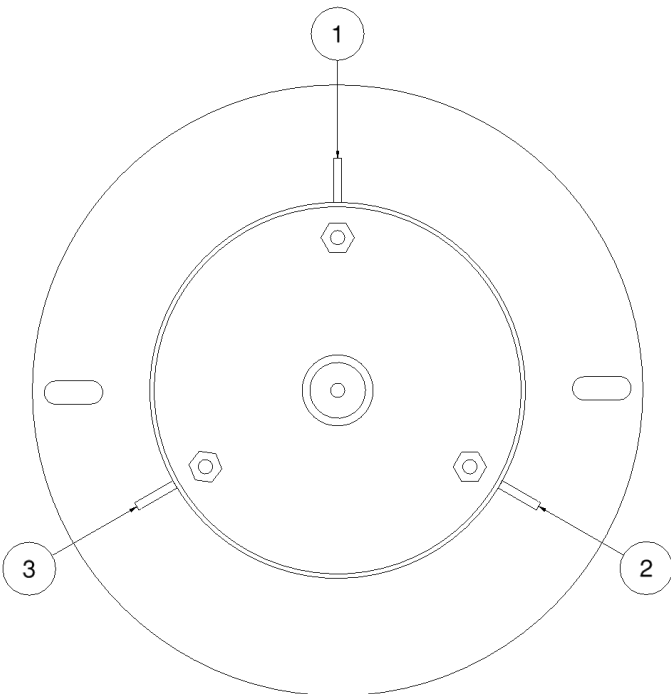

ROUTINE MAINTENANCE

13. Continue this pattern until all “wavy” brush sections are installed.

NOTE: Install 38 “wavy” brush sections on a 72” arbor, or 44 “wavy” brush sections on an 84” arbor.

14. Reinstall the brush retainer and three bolts.
15. Slide the bearing/endplate assembly onto the end of the arbor. Tighten the bearing setscrews, and reinstall the bearing retaining bolt and washer.



16. Move the arbor and brush assembly into the bucket housing. Lower the hood and make sure the endplates and rubber side shields are in place for reinstallation.



17. Align the bolt holes and secure the endplates to the hood. Slide the motor and endplate assembly into the arbor, aligning the hex drive block inside the arbor.

18. Be sure to adjust the arbor height to ensure a 2” to 4” bristle contact area. This is done by positioning the rear endplate bolts in the appropriate holes on the adjustment bars.



19. Tighten all hardware to the proper torque(s). Refer to the bolt torque chart on page 29 of this manual.

SET-UP ASSEMBLY

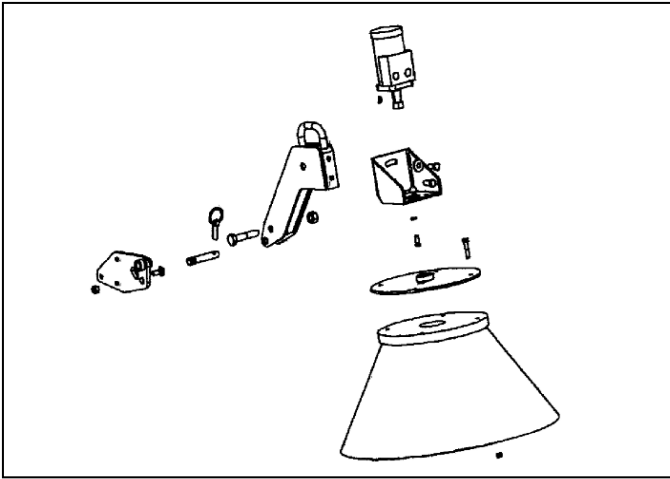

Curb Sweeper Installation

Unpack the parts and compare them to the parts list. If any parts are damaged or missing, contact Erskine Attachments LLC for replacement parts.

The curb sweeper is designed to be mounted on either the right or the left side. Ideally, it is recommended to mount the curb sweeper on the right side (farthest away from the operator).

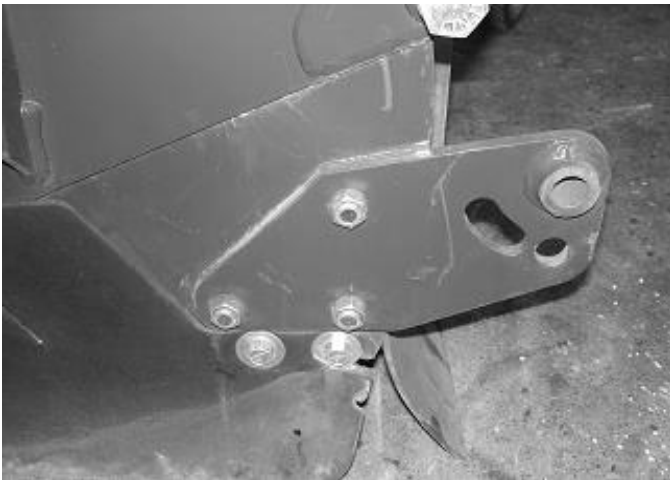

1. Attach the mount plate with the three carriage bolts and lock nuts provided.

IMPORTANT: Tighten the mounting bolts to 65-70 ft.-lbs.

NOTE: The shield may be removed to allow easier access to the mounting holes.



2. Mount the sweeper arm to the mounting bracket using the 3/4" x 3-1/2" bolt and lock nut provided. Position the sweeper arm in the up position, and secure in place with the 3-point pin and lynch pin.

IMPORTANT: Tighten the bolts to 220-240 ft.-lbs.

SET-UP ASSEMBLY

3. Mount the motor bracket to the sweeper arm using two 1/2" x 1-1/4" bolts and one 1/2" flat washer as shown.

IMPORTANT: Tighten the bolts to 65-70 ft.-lbs.



4. Mount the motor to the motor bracket using the four bolts and lock washers.

IMPORTANT: Tighten the bolts to 25-30 ft.-lbs.

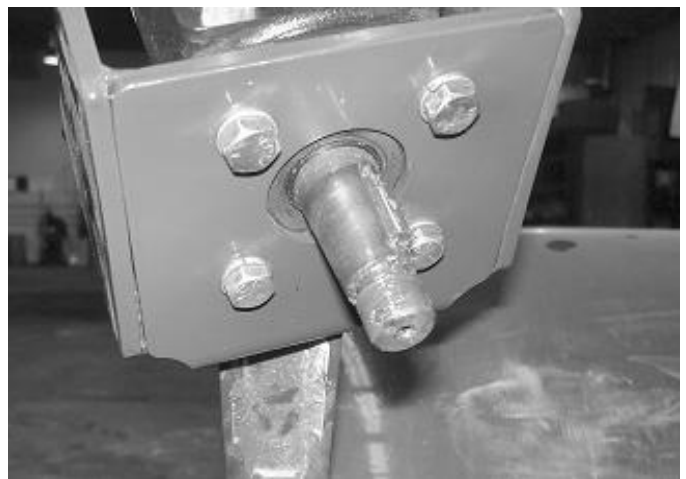

5. Install the two straight hydraulic fittings into the motor. Be sure to leave the exposed ends capped until the hoses are installed.

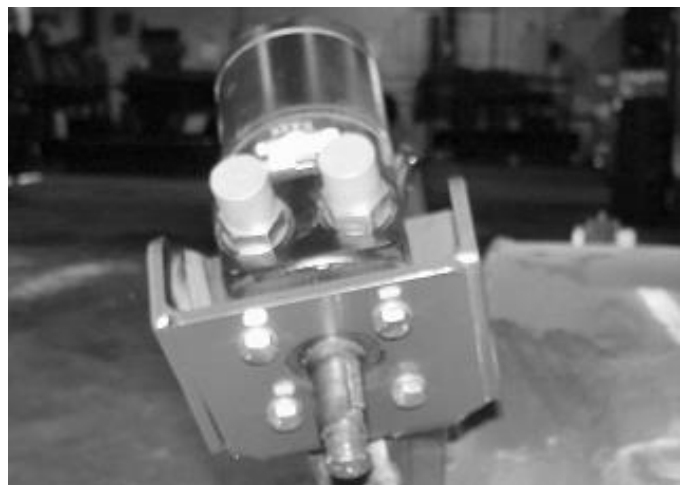

SET-UP ASSEMBLY



6. Mount the hub plate to the motor using the woodruff key and nut.



7. Mount the sweeper brush to the hub plate with the four 3/8" x 2" bolts and lock nuts.

IMPORTANT: Tighten the bolts to 25-30 ft.-lbs.

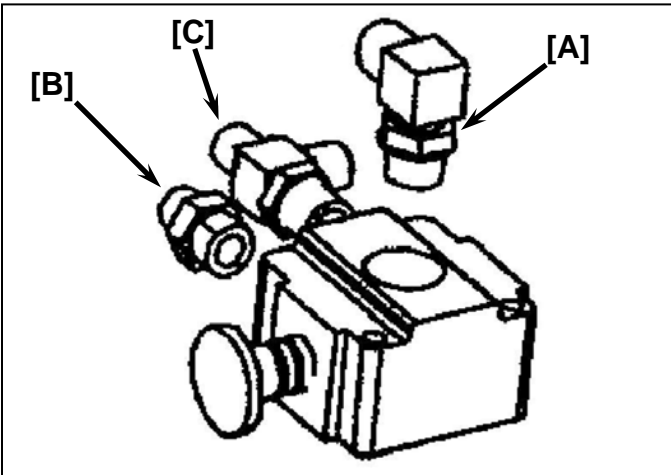

8. Attach the elbow [A], straight [B], and tee [C] fittings to the valve as shown, if not already pre-assembled.

SET-UP ASSEMBLY

9. Mount the selector valve with the two bolts and lock nuts provided. Reach underneath the rear rubber shield in order to install the lock nut.

IMPORTANT: Tighten the bolts to 25-30 ft.-lbs.

NOTE: Do not overtighten the bolts, as this will interfere with the valve's operation.



10. Attach the 90° hose ends of the 120" hoses to the motor mounted on the curb sweeper.

If installing the curb sweeper on the right side of the attachment, attach the hose from port "A" on the motor to the tee adaptor, and attach the hose from port "B" on the motor to the straight adaptor. Reverse the hose orientation if mounting the curb sweeper on the left side of the attachment. This will ensure proper brush rotation.



11. Route the valve-to-motor hoses as shown, and secure in place with the provided cable ties.



SET-UP ASSEMBLY

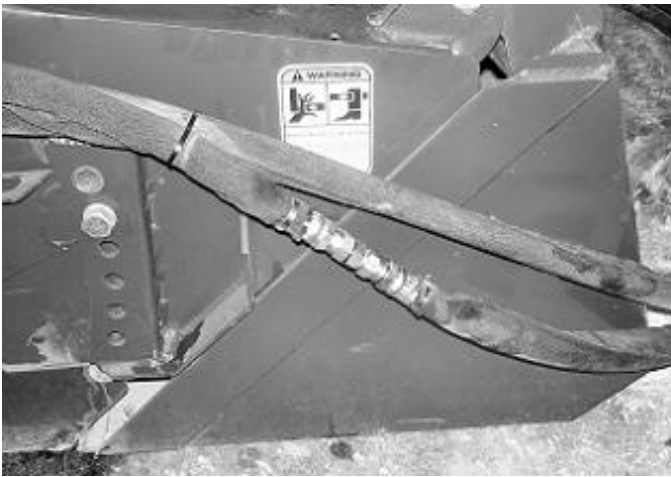

12. Remove the union fitting from the two-piece lead hose.

NOTE: Have a pan ready to catch the hydraulic fluid from the hoses.

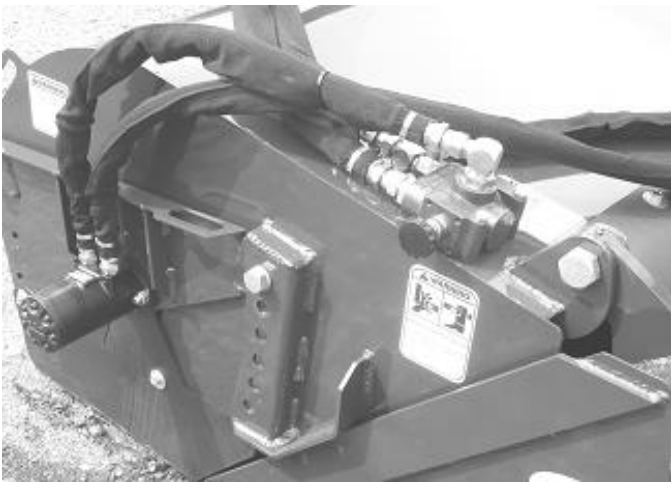

13. Connect the shorter hose from the motor to the elbow fitting on top of the selector valve. Connect the longer hose to the tee fitting.



14. Clean the surface of the hood next to the valve block, and install the "On-Off" decal as shown.

IMPORTANT: Refer to pages 11-12 of the "Operating Instructions" in this manual for proper operation of the curb sweeper.

SET-UP ASSEMBLY

Water Kit Installation

Unpack the parts and verify that all parts are included. If any parts are damaged or missing, contact Erskine Attachments LLC for replacement parts.

Nozzle Body Assembly

1. Insert the brass spray tip into the nozzle cap.
2. Insert the rubber gasket into the nozzle cap on top of the inlet side of the brass tip.
3. Insert the tip strainer into the nozzle body. The mesh in the strainer goes inside of the nozzle body.
4. Align the notches on the nozzle body with the recesses in the nozzle cap, and twist one quarter turn to secure the assembly.
5. Repeat all steps for the three remaining nozzle body assemblies.



SET-UP ASSEMBLY



6. Loosen the screw in the nozzle clamp and insert the nozzle body. Tighten the screw to secure the nozzle body. Repeat for the three remaining nozzle body assemblies.

NOTE: The two single nozzle bodies should have opposite orientations in the nozzle clamps.



Hose Assembly

1. When assembling the hoses, it is helpful to place both hose clamps around the hose before inserting any fittings. Use the three short 3/8" ID hoses to connect the nozzle bodies.

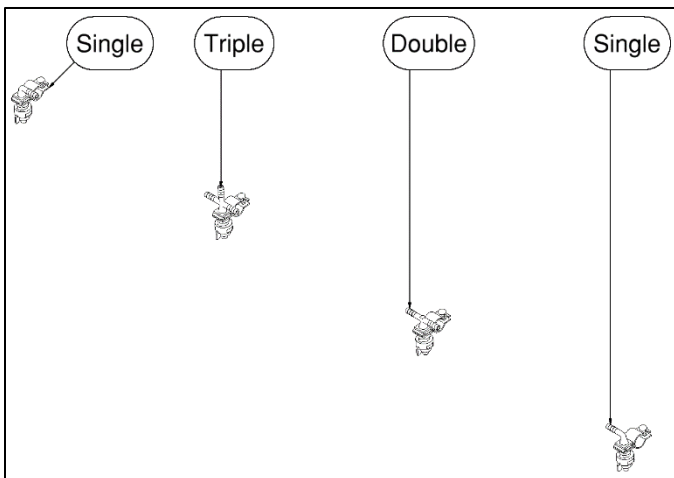

The fittings order from right to left (as viewed from sitting in the loader's operator's seat) is as follows: single, triple, double, and single.

SET-UP ASSEMBLY

2. Before tightening the hose clamps, adjust the orientation of the nozzle bodies so they are approximately aligned. Fine adjustments can be made later when the spray boom is mounted on the broom.

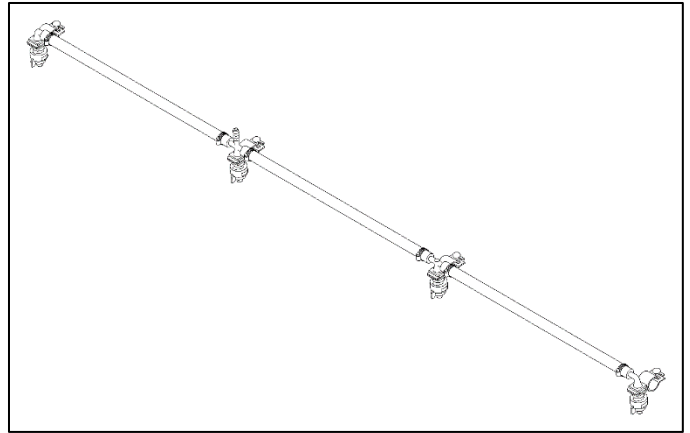

3. Slide the hose clamp over the location of the barb on the fitting and tighten using a screwdriver or 1/4" nut driver. Tighten until snug.

IMPORTANT: Do not over-tighten. Over-tightening the hose clamp may damage the hose.



4. Remove the male plug from the coupler and insert into one end of the shortest 3/8" ID hose. Secure with hose clamps. Insert the 3/8" swivel fitting at the other end. Tighten hose clamps. This is the pump outlet hose.

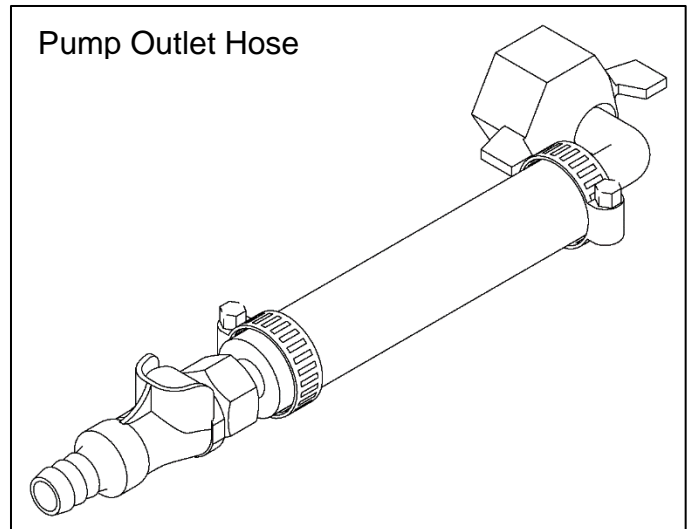

SET-UP ASSEMBLY

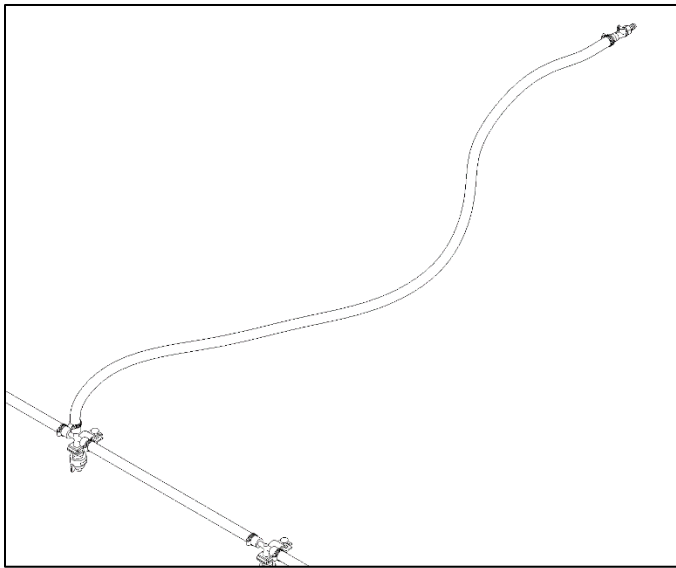

5. Insert the female end of the coupler into one end of the longest 3/8" ID hose and secure with hose clamps. Connect the other end of the hose to the triple nozzle body. Tighten the hose clamps.

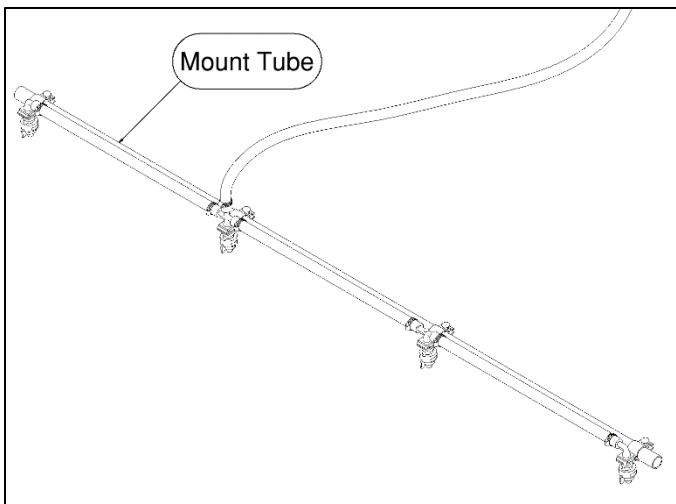

6. The spray boom hose assembly can now be mounted to the tube.

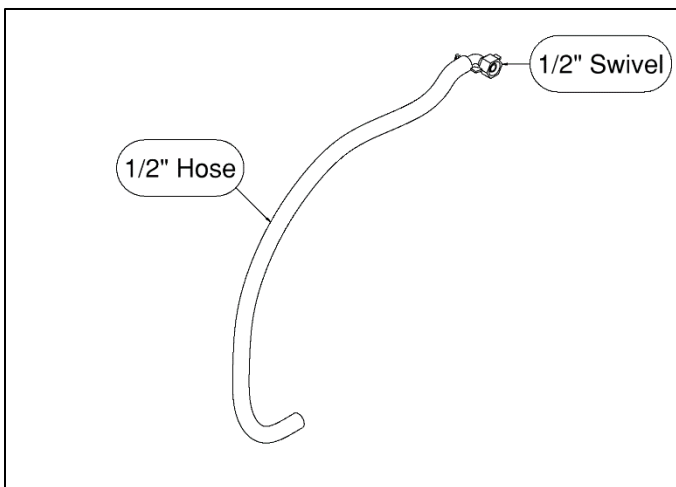

7. Connect the 1/2" hose to the 1/2" swivel fitting using hose clamps. This is the pump inlet hose.

SET-UP ASSEMBLY

- Remove the plug from the outlet port at the bottom of the water tank. Thread the straight adapter and 1/2" straight fitting into the outlet port.

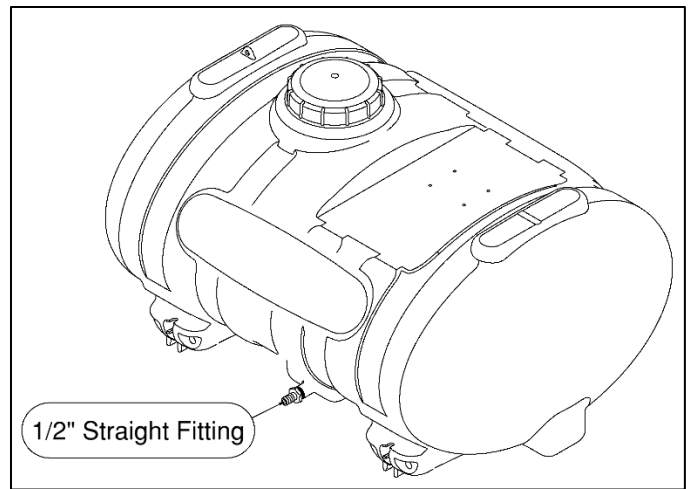

- Thread the swivel end of the line strainer onto the inlet side of the pump. Thread the 3/8" swivel fitting from the pump outlet hose onto the outlet side of the pump.

IMPORTANT: Swivel fittings are designed to be hand tightened only. Over-tightening swivel fittings can damage the fitting and/or pump.

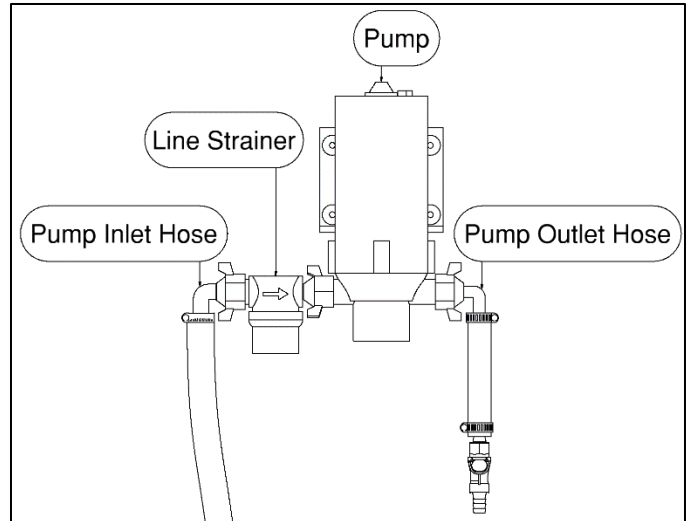

Mounting the Water Tank

- Attach tank mount to top of hood using bolts and washers provided.

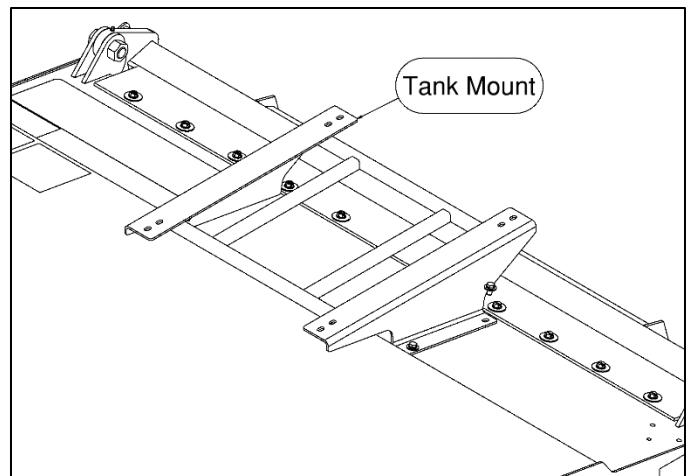

SET-UP ASSEMBLY

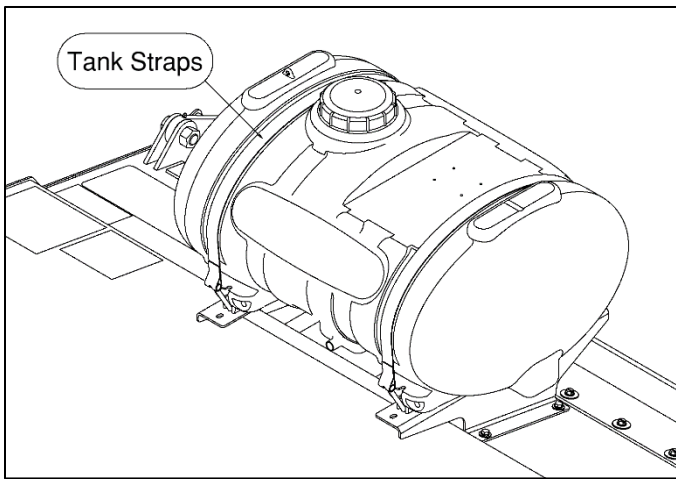

2. Place tank on tank mount, and secure to mount using steel tie-down straps provided.

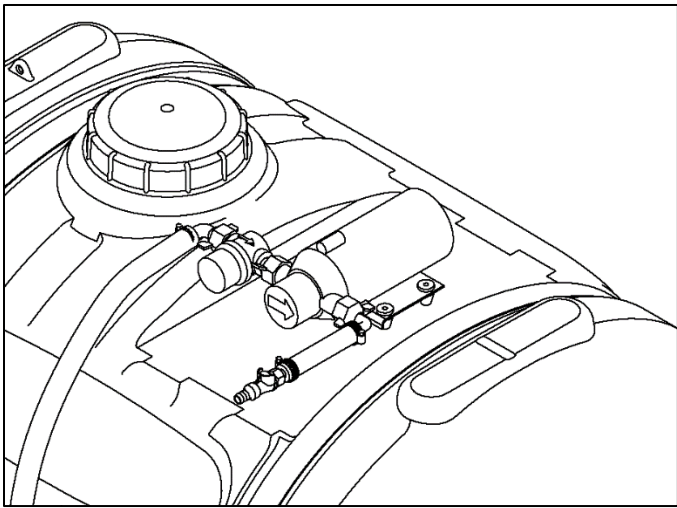

3. Mount water pump on top of tank and secure using screws provided.

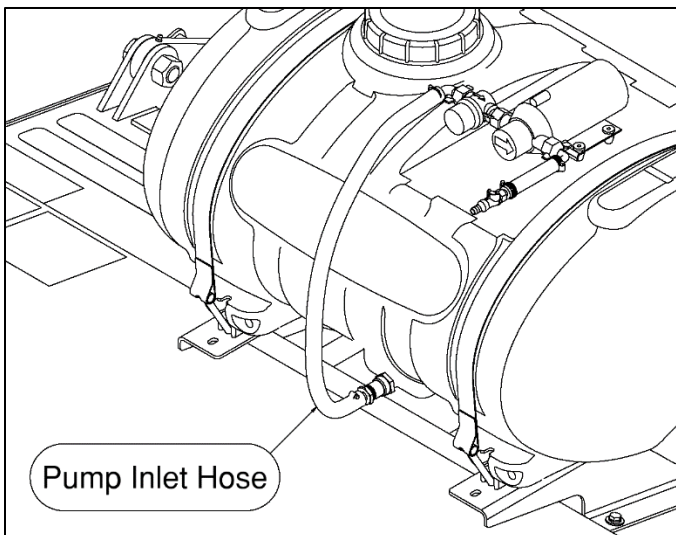

4. Connect pump inlet hose to tank outlet fitting, and tighten hose clamp.

SET-UP ASSEMBLY

5. Bolt spray boom mount brackets to caster plates on front of hood.

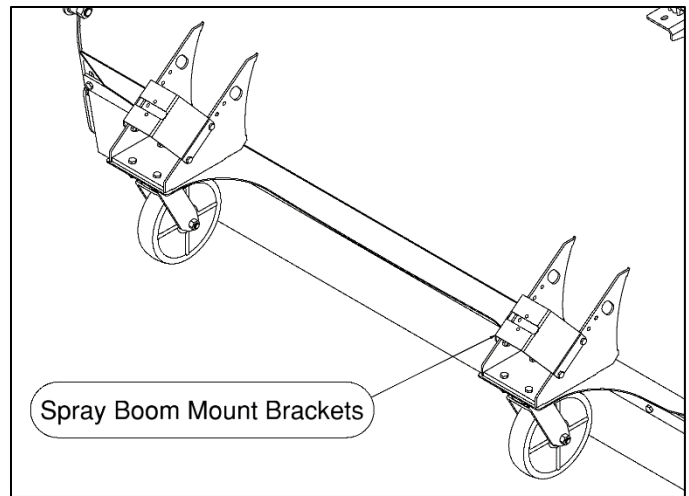

6. Attach spray boom to mount brackets using U-bolts. Make sure spray tips are pointed down, and tighten U-bolts to secure spray boom in place.

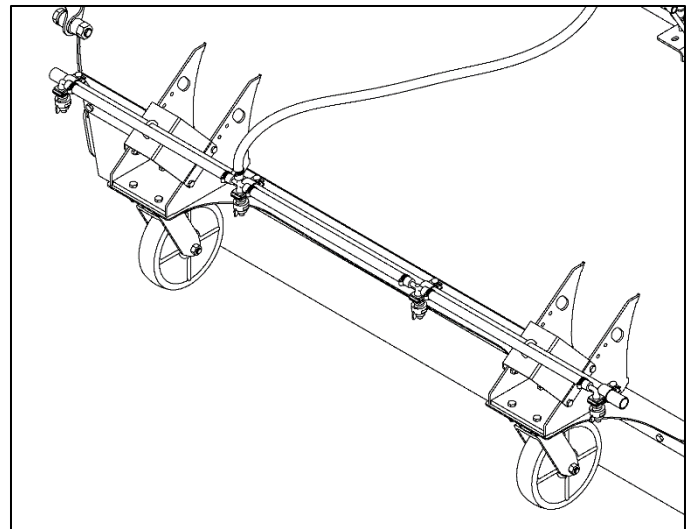

7. Connect pump outlet hose and spray boom hose by connecting the quick coupler halves.

8. Installation of the water kit is complete. To turn the pump on, plug the power cord into the loader's 12V receptacle. To turn the pump off, remove the plug from the 12V receptacle.

IMPORTANT: The 12V receptacle is not mounted on the loader lift arms, therefore the distance between the 12V socket and the pump will change as the lift arms are raised. Be sure there is sufficient slack when dumping the pick-up broom. Check the harness slack through the full range of intended motion of the attachment before operating. Proper wire harness routing is the responsibility of the owner and/or operator. Pinched or stretched wire harnesses are not covered under warranty.

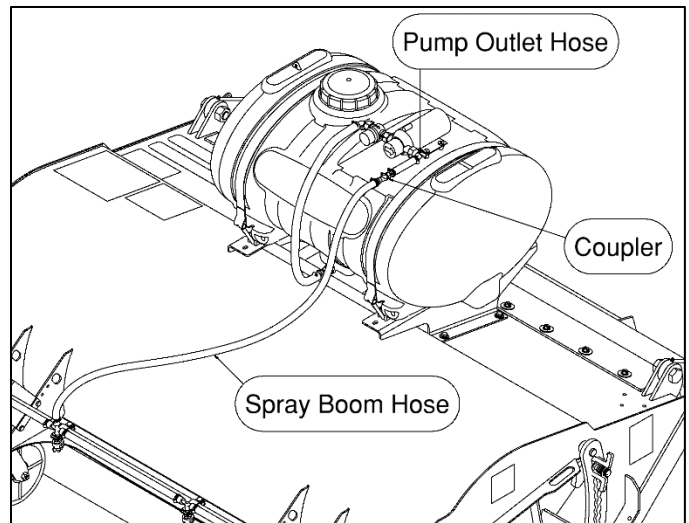

NOTE: If the water kit is being run for the first time, or if it was previously run until empty, the pump may need to prime before it starts spraying. The pump will self-prime and begin to spray in less than 1 minute.

BOLT TORQUE INFORMATION

Torque-Tension Relationships for SAE J429 Grade Bolts

Nominal Thread Size	SAE J429 Grade 2			SAE J429 Grade 5			SAE J429 Grade 8		
	Clamp Load (lbs)	Tightening Torque		Clamp Load (lbs)	Tightening Torque		Clamp Load (lbs)	Tightening Torque	
		K = .15	K = .20		K = .15	K = .20		K = .15	K = .20
Unified Coarse Thread Series									
1/4-20	1,300	49 in-lbs	65 in-lbs	2,000	75 in-lbs	100 in-lbs	2,850	107 in-lbs	143 in-lbs
5/16-18	2,150	101	134	3,350	157	210	4,700	220	305
3/8-16	3,200	15 ft-lbs	20 ft-lbs	4,950	23 ft-lbs	31 ft-lbs	6,950	32.5 ft-lbs	44 ft-lbs
7/16-14	4,400	24	30	6,800	37	50	9,600	53	70
1/2-13	5,850	36.5	49	9,050	57	75	12,800	80	107
9/16-12	7,500	53	70	11,600	82	109	16,400	115	154
5/8-11	9,300	73	97	14,500	113	151	20,300	159	211
3/4-10	13,800	129	173	21,300	200	266	30,100	282	376
7/8-9	11,425	125	166	29,435	321	430	41,550	454	606
1-8	15,000	187.5	250	38,600	482.5	640	54,540	680	900
Unified Fine Thread Series									
1/4-28	1,500	55 in-lbs	75 in-lbs	2,300	85 in-lbs	115 in-lbs	3,250	120 in-lbs	163 in-lbs
5/16-24	2,400	112	150	3,700	173	230	5,200	245	325
3/8-24	3,600	17 ft-lbs	22.5 ft-lbs	5,600	26 ft-lbs	35 ft-lbs	7,900	37 ft-lbs	50 ft-lbs
7/16-20	4,900	27	36	7,550	42	55	10,700	59	78
1/2-20	6,600	41	55	10,200	64	85	14,400	90	120
9/16-18	8,400	59	79	13,000	92	122	18,300	129	172
5/8-18	10,600	83	110	16,300	128	170	23,000	180	240
3/4-16	15,400	144	193	23,800	223	298	33,600	315	420
7/8-14	12,610	138	184	32,480	355	473	45,855	500	668
1-12	16,410	205	273	42,270	528	704	59,670	745	995

Clamp load estimated as 75% of proof load for specified bolts.

Torque values for 1/4 and 5/16 inch series are in inch-pounds. All other torque values are in foot-pounds.

Torque values calculated from formula $T = KDF$

where: $K=0.15$ for "lubricated" conditions

$K=0.20$ for "dry" conditions

PARTS INFORMATION

ITEM	QTY	PART NO.	DESCRIPTION	STOCK NO.
1	1	350318	BODY PUB 72 HD W/A	
	1	318545	BODY PUB 84 HD W/A	
2	1	350311	BUCKET PUB 72 HD W/A	
	1	318591	BUCKET PUB 84 HD W/A	
3	1	318575	BRKT PIVOT RH W/A	
4	1	318553	BRKT PIVOT LH W/A	
5	2	318554	HANDLE PUB W/A	
6	1	103835	BRG 1-1/2 2-B FLG	
7	2	318557	SPRING COMP .97 OD X 2	
8	2	33090	WASHER FLAT SAE	5/8"
9	2	318558	BOLT SHOULDER	5/8 X 2-1/4 UNC
10	1	13105	BOLT HEX	3/8 X 1 NC GR 5
11	1	318430	CUTTING EDGE B 74 DB	
	1	318474	CUTTING EDGE B 86 DB	
12	4	37214	NUT REV LOCK	1/2 NC GR A Z
13	4	13209	BOLT HEX	1/2 X 1-1/2 NC GR 5
14	2	33632	WASHER LOCK	3/4"
15	1	202830	WASHER PLATE .41 X 1.75 X .13 Z	
16	2	13365	BOLT HEX	3/4 X 3 NC GR 5
17	7	36314	NUT HEX FULL	5/8 NC GR 5 Z
	8	36314	NUT HEX FULL	5/8 NC GR 5 Z
18	7	33630	WASHER LOCK	5/8"
	8	33630	WASHER LOCK	5/8"
19	7	22664	BOLT PLOW	5/8 X 1-3/4 NC GR5
	8	22664	BOLT PLOW	5/8 X 1-3/4 NC GR5
20	2	13463	BOLT HEX	1 X 2-1/2 NC GR 5
21	2	37219	NUT REV LOCK	1 NC GR A Z
22	2	33626	WASHER LOCK	1/2"

PARTS INFORMATION

ITEM	QTY	PART NO.	DESCRIPTION	STOCK NO.
1	1	318417	FLAT MAT CLAMP 72 PUB Z	
	1	318473	FLAT MAT CLAMP 84 PUB Z	
2	1	318426	SHIELD RUBBER FRONT 72 PUB	
	1	318471	SHIELD RUBBER FRONT 84 PUB	
3	2	318563	SHIELD RUBBER SIDE	
4	1	318432	SHIELD RUBBER TOP 72	
	1	318475	SHIELD RUBBER TOP 84	
5	2	318559	WHEEL CASTER ASSM 10.13 X 8 X 2	
6	10	13105	BOLT HEX	3/8 X 1 NC GR 5
	12	13105	BOLT HEX	3/8 X 1 NC GR 5
7	2	13217	BOLT HEX 1/2 X 3-1/2 NC GR 5	COMES WITH WHEEL 318559
8	2	37214	NUT REV LOCK 1/2 NC GR A Z	COMES WITH WHEEL 318559
9	20	32467	BOLT THDCUT FLG	3/8 X 3/4 NC
	21	32467	BOLT THDCUT FLG	3/8 X 3/4 NC
10	20	33220	WASHER FENDER	3/8 X 1 1/2
	21	33220	WASHER FENDER	3/8 X 1 1/2
11	18	37212	NUT REV LOCK	3/8 NC GR A Z
	20	37212	NUT REV LOCK	3/8 NC GR A Z
12	8	33008	WASHER FLAT USS	3/8"
13	8	103879	BOLT HEX	3/8 X 1-1/2 NC GR 5

PARTS INFORMATION

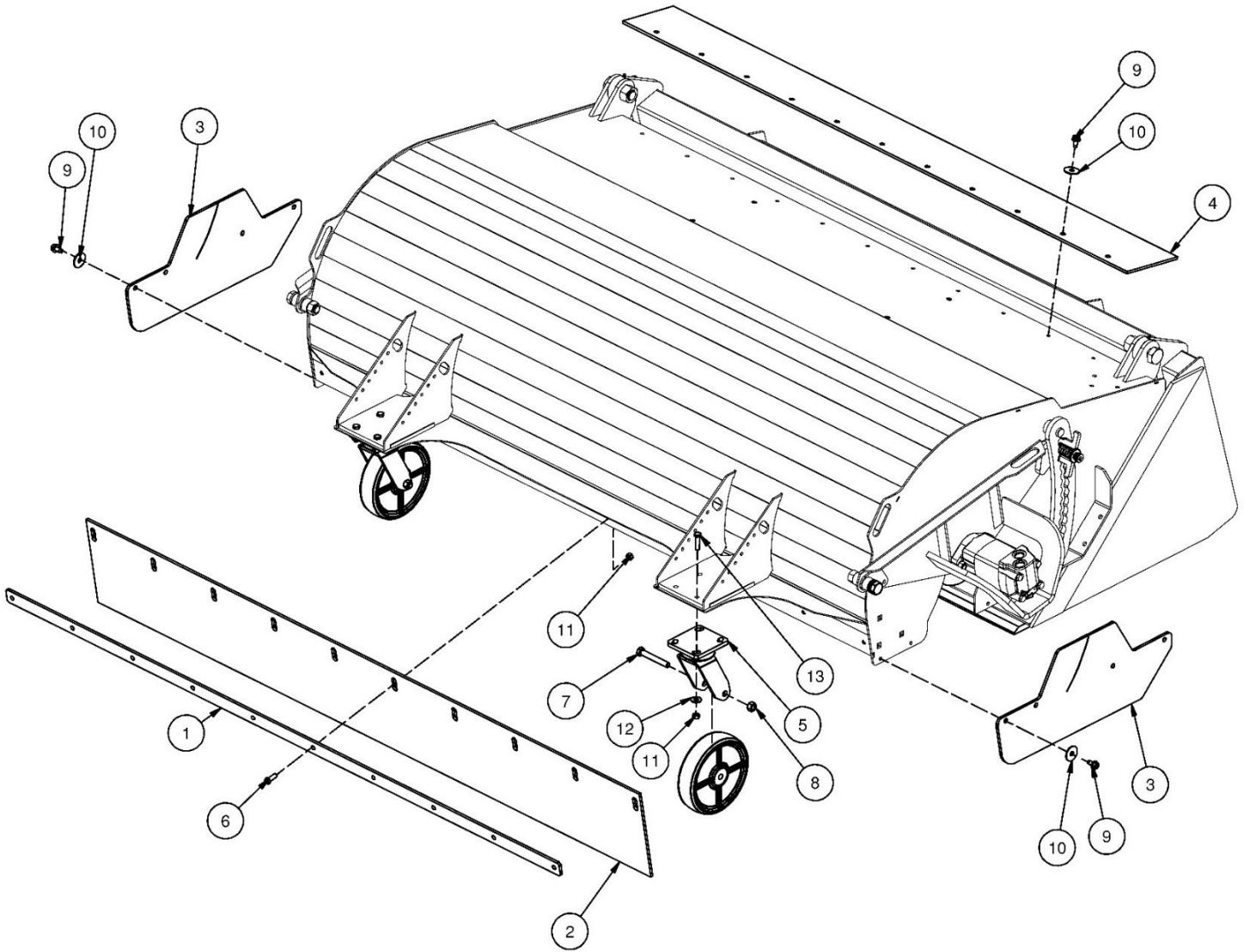

PARTS INFORMATION

ITEM	QTY	PART NO.	DESCRIPTION	STOCK NO.
1	1	350322	ARBOR PUB 6 X 72 HD W/A	
	1	318580	ARBOR PUB 6 X 84 HD W/A	
2	1	318542	ENDPLATE ARBOR 9.69 OD PAINTED	
3	1	316032	DRIVE BLOCK HEX 1.25" BORE W/SNAP RING	
4	1	313333	RING SNAP EXT 2 X .063	
5	1	13007	BOLT HEX	1/4 X 1-1/4 NC GR 5
6	1	103835	BRG 1-1/2 2-B FLG	
7	3	103880	WASHER LOCK	3/8"
8	1	33618	WASHER LOCK	1/4"
10	4	13105	BOLT HEX	3/8 X 1 NC GR 5
12	2	37214	NUT REV LOCK	1/2 NC GR A Z
13	2	13209	BOLT HEX	1/2 X 1-1/2 NC GR 5
15	2	202830	WASHER PLATE .41 X 1.75 X .13 Z	
16	1	33004	WASHER FLAT USS	1/4"
17	**	318582	WAFER PUB CONV POLY 6.38 X 26	
	**	350326	WAFER PUB CONV STEEL 6.38 X 26	
		318504	PKG WAFER 72 PUB HD POLY (26")	39 POLY WAFERS
		318505	PKG WAFER 72 PUB HD POLY/STEEL (26")	20 POLY/19 STEEL WAFERS
		318506	PKG WAFER 72 PUB HD STEEL (26")	39 STEEL WAFERS
		318507	PKG WAFER 84 PUB HD POLY (26")	45 POLY WAFERS
		318508	PKG WAFER 84 PUB HD POLY/STEEL (26")	23 POLY/22 STEEL WAFERS
		318509	PKG WAFER 84 PUB HD STEEL (26")	45 STEEL WAFERS

PARTS INFORMATION

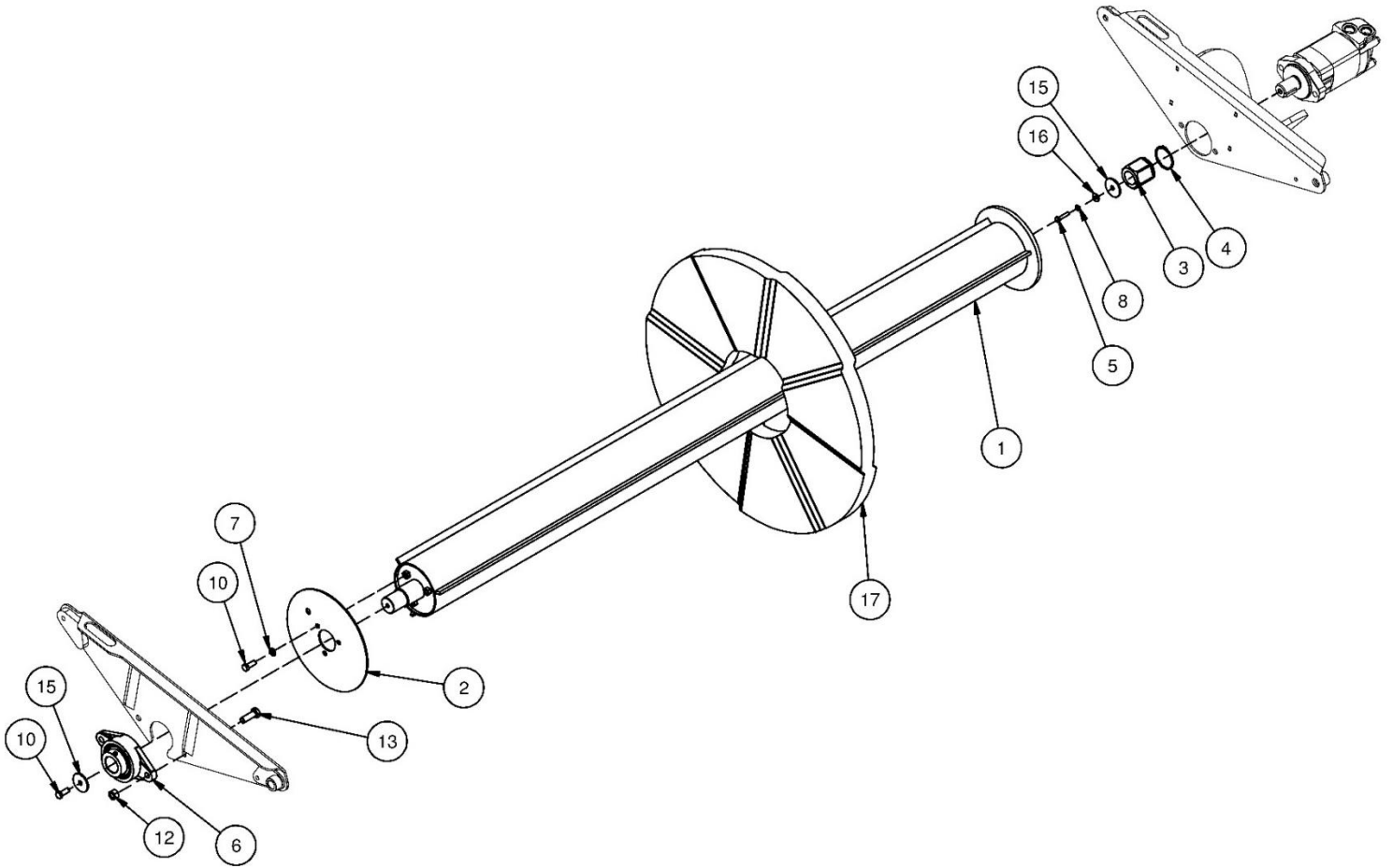

PARTS INFORMATION

ITEM	QTY	PART NO.	DESCRIPTION	STOCK NO.
1	1	320083	MOTOR 14.9 2K 1.25 KEYED	REPLACED BY 103396
	1	103396	MOTOR 24 2K 1.25 KEYED	
2	1	318489	HOSE 5/8 X 116 12FJX-10MB	
3	1	318491	HOSE 5/8 X 89" 10FJX-12FJX	
4	1	318490	HOSE 5/8 X 32 10MB-10FJX	
5	1	300214	ADPT NIPPLE 10MJ-10MJ	
6	1	315639	CLAMP HOSE 1-1/2 (R CLAMP)	
7	1	32467	BOLT THDCUT FLG	3/8 X 3/4 NC

PARTS INFORMATION

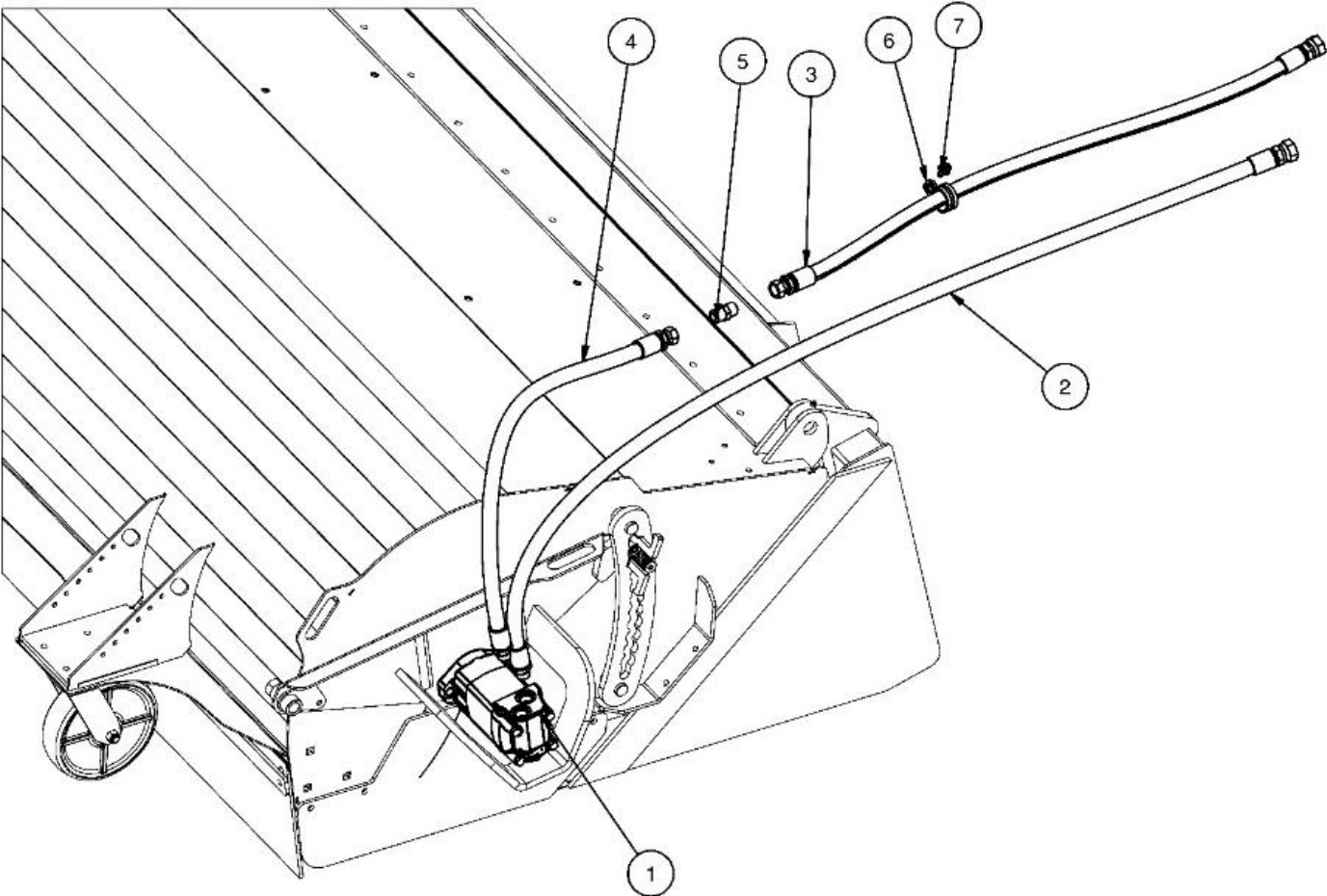

PARTS INFORMATION

ITEM	QTY	PART NO.	DESCRIPTION	STOCK NO.
		900579	PKG OPT CURB SWEEPER	
1	1	318405	ARM CURB SWEEPER W/A	
2	1	318449	BRACKET MOTOR W/A PAINTED	
3	1	318406	MOUNT CURB SWEEPER W/A	
4	1	318407	HUB PLATE CS W/A	
5	1	318437	CURB SWEEPER STEEL	
6	1	318445	MOTOR 22.6 H SERIES 1" TAPER	
7	4	103880	WASHER LOCK	3/8"
8	1	104432	PIN LYNCH 7/16 X 1-3/4	
9	1	100540	WOODRUFF KEY 1/4 X 1	COMES WITH MOTOR
10	4	13105	BOLT HEX	3/8 X 1 NC GR 5
11	4	37212	NUT REV LOCK	3/8 NC GR A Z
12	3	37214	NUT REV LOCK	1/2 NC GR A Z
13	1	37217	NUT REV LOCK	3/4 NC GR A Z
14	4	13111	BOLT HEX	3/8 X 2 NC GR 5
15	2	13207	BOLT HEX	1/2 X 1-1/4 NC GR 5
16	1	13365	BOLT HEX	3/4 X 3 NC GR 5
17	1	104397	PIN 3-PT CAT1 TOP 3/4 X 2-3/4	
18	1	33012	WASHER FLAT USS	1/2"
19	3	200066	BOLT CARRIAGE	1/2 X 1-1/4 NC GR 5

PARTS INFORMATION

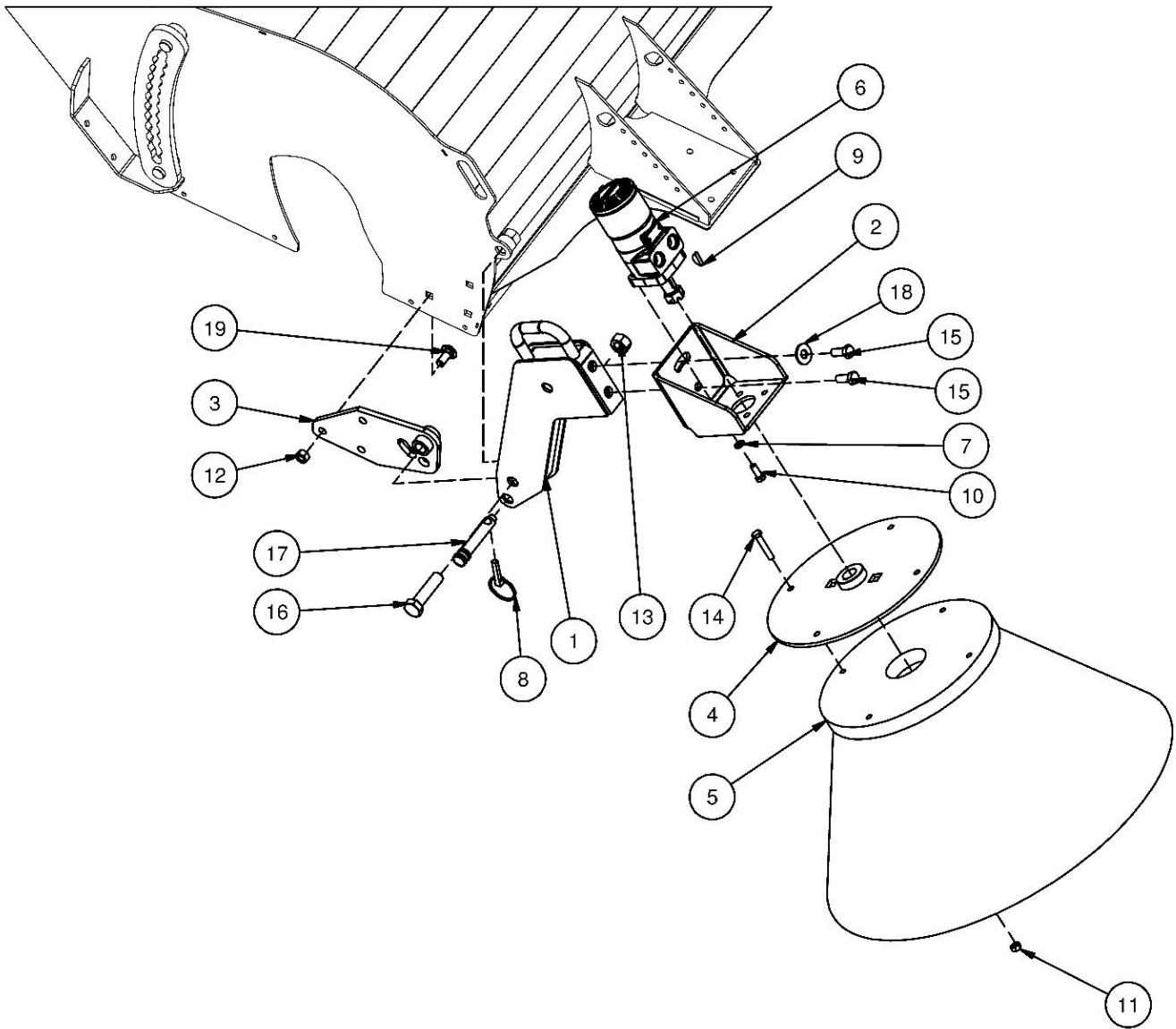

PARTS INFORMATION

ITEM	QTY	PART NO.	DESCRIPTION	STOCK NO.
		900579	PKG OPT CURB SWEEPER	
1	1	320083	MOTOR 14.9 2K 1.25 KEYED	
2	1	318441	VALVE 4-WAY SELECT MANUAL	
3	1	318489	HOSE 5/8 X 116 12FJX-10MB	
4	1	318490	HOSE 5/8 X 32 10MB-10FJX	
5	2	318492	HOSE 5/8 X 120 10FJX-10FJX90	
6	1	318445	MOTOR 22.6 H SERIES 1" TAPER	
7	2	201852	ADPT STR 10MB-10MJ	
8	1	201851	ADPT STR 12MB-10MJ	
9	1	300216	ADPT TEE 12MB-10MJ-10MJ	
10	1	300215	ADPT ELB 12MB-10MJ-90	
11	1	318491	HOSE 5/8 X 89" 10FJX-12FJX	
12	2	13114	BOLT HEX	3/8 X 2-3/4 NC GR5

PARTS INFORMATION

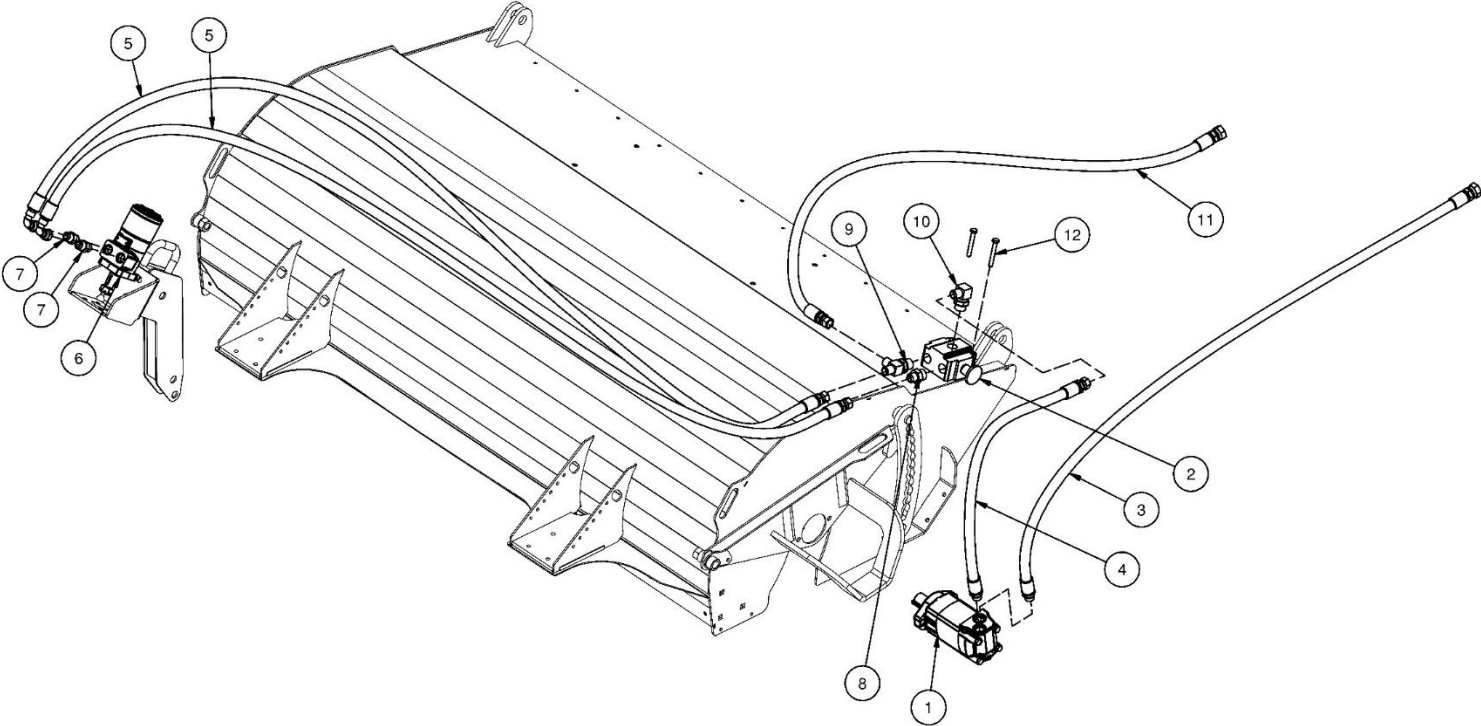

PARTS INFORMATION

ITEM	QTY	PART NO.	DESCRIPTION	STOCK NO.
		350302	PKG OPTIONAL WATER KIT HD PICKUP BROOM	
1	1	350304	TANK 40 GAL WATER	
2	1	350310	STAND WATER TANK W/A	
3	2	350303	BRKT BOOM SUPPORT PAINTED	
4	1	318648	TUBE RND 1 X .83 X 64 W/H PAINTED	
5	1	318663	HOSE 3/8 X 54 NO FITTINGS	
6	4	318645	CLAMP NOZZLE	
7	4	103880	WASHER LOCK 3/8	3/8"
8	2	42004	U-BOLT	1/4 X 1-3/4 NC GR 5 RD BEND
9	4	37210	NUT REV LOCK	1/4 NC GR A Z
10	8	318296	NUT TOP LOCK	5/16-18 NC GRD C (GR8)
11	8	13053	BOLT HEX	5/16 X 3/4 NC GR 5
12	4	33008	WASHER FLAT	3/8"
13	4	13103	BOLT HEX	3/8 X 3/4 NC GR 5
14	1	318656	HRN WATER KIT 12V	NOT SHOWN

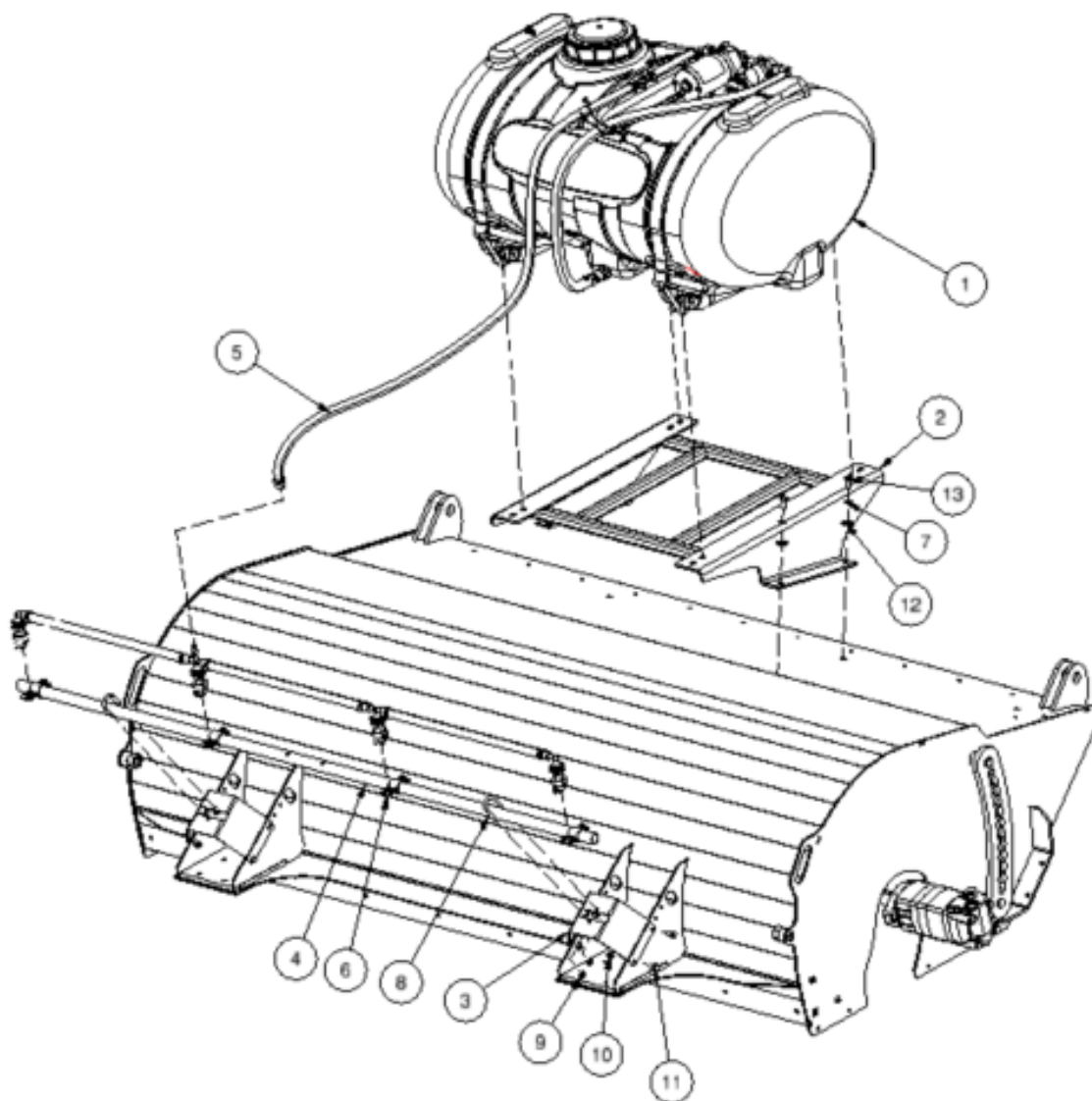

PARTS INFORMATION

ITEM	QTY	PART NO.	DESCRIPTION	STOCK NO.
		350302	PKG OPTIONAL WATER KIT HD PICKUP BROOM	
1	2	350305	STRAP SS 42.5 X .062 X 1.25	
2	3	318665	HOSE 3/8 X 19 NO FITTINGS	
3	1	318616	NOZZLE BODY DOUBLE QUICK	
4	1	318617	NOZZLE BODY TRIPLE QUICK	
5	2	318615	NOZZLE BODY SINGLE QUICK	
6	4	318623	PLATE VERTICAL ADAPTER	PART OF 318654
7	4	318620	GASKET TIP EPDM	PART OF 318654
8	4	318638	TIP SPRAY FLOODJET BRASS	
9	4	318637	TIP STRAINER	
10	6	62003	CLAMP HOSE 5/16 X 7/8 (06)	

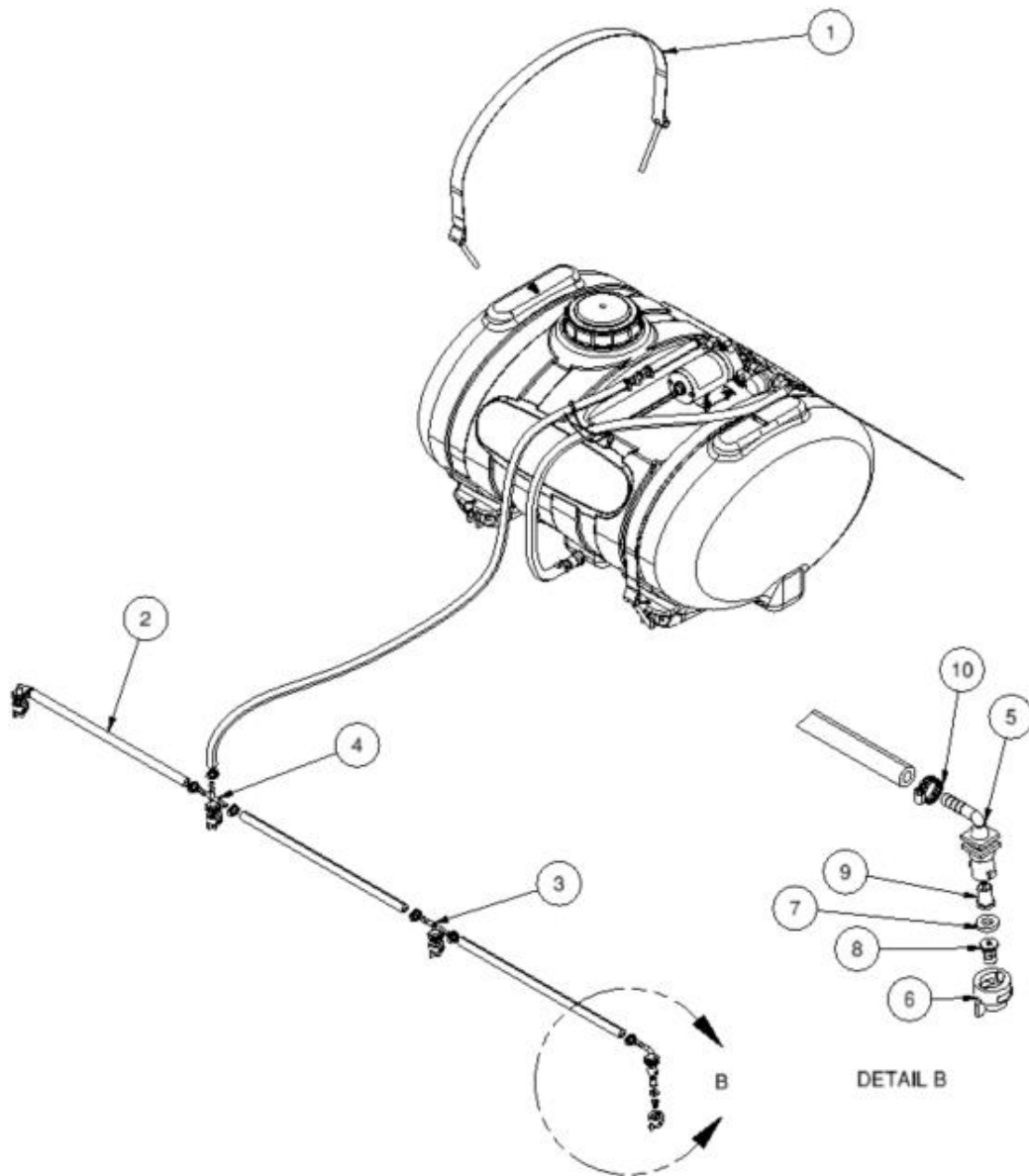

PARTS INFORMATION

ITEM	QTY	PART NO.	DESCRIPTION	STOCK NO.
		350302	PKG OPTIONAL WATER KIT HD PICKUP BROOM	
5	1	318663	HOSE 3/8 X 54 NO FITTINGS	
6	1	350330	HOSE 1/2 X 36 NO FITTINGS	
7	1	350331	HOSE 3/8 X 6 NO FITTINGS	
8	1	318658	PUMP WATER ASSM	REPLACED 318610
	1	318610	PUMP WATER ASSM OBLT	REPLACED BY 318658
9	1	318611	INLET STRAINER 1/2 NPS-M X 1/2	
10	5	62003	CLAMP HOSE 5/16 X 7/8 (06)	
11	1	350333	ADPT STR 3/4 FGHT-1/2 FPT	
12	1	350332	ADPT STR 1/2 NPT 1/2 HB NYLON	
13	1	318613	ADPT ELB 1/2 BARB POLY	
14	1	318619	CPLR QUICK 3/8 HB W/CHECK	
15	1	318614	ADPT ELB 3/8 BARB POLY	
16	2	318659	ADPT STR 3/8 MPT X 1/2 MPT NYLON	
17	4	33074	WASHER FLAT SAE #10	ECN 4318
18	4	331510	BOLT SHCS #10-24 X 1.25 NC BO	ECN 4318

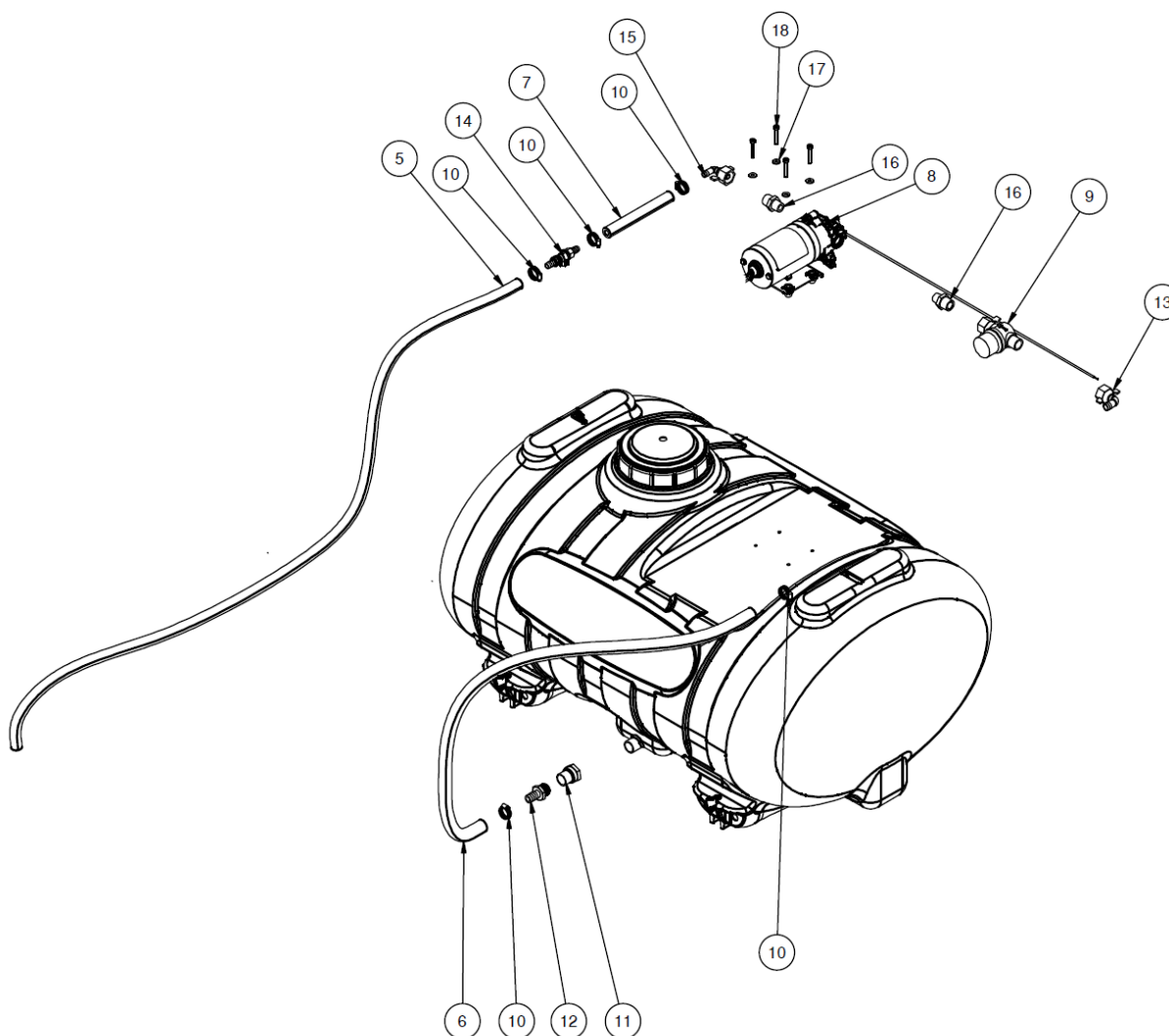

GENERAL SPECIFICATIONS

Model	72	84
Working Width	72"	84"
Wafer Diameter	26.25"	
Wafer Quantity	38	44
Cutting Edge	5/8" x 6" Bolt-on, reversible	
Drive System	Direct Drive Hydraulic Motor	
Hydraulic Flow Range	13 - 25 GPM	
Operating Weight (Standard)	960 lbs.	1050 lbs.
<i>Optional Curb Sweeper</i>		
Curb Sweeper Drive System	Direct Drive Hydraulic Motor	
Curb Sweeper Diameter	26"	
Curb Sweeper Bristle Material	Steel or Poly	
<i>Optional Water Kit</i>		
Water Tank Capacity	40 gal	
Water Pump	Electric (12V), Self-Priming	

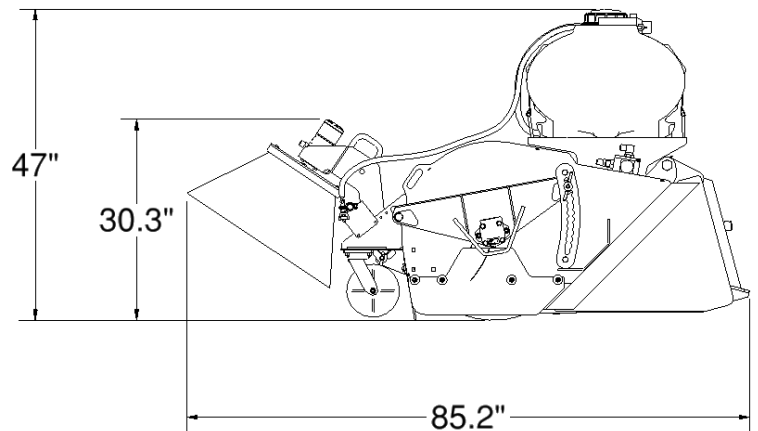
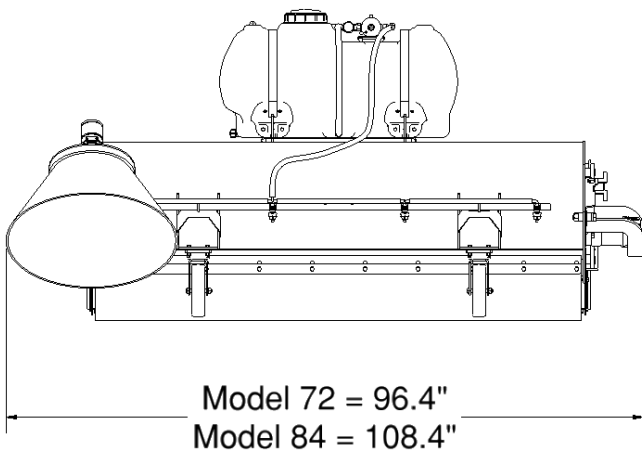
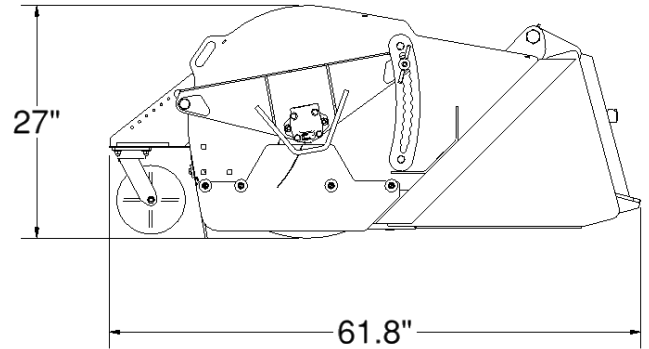
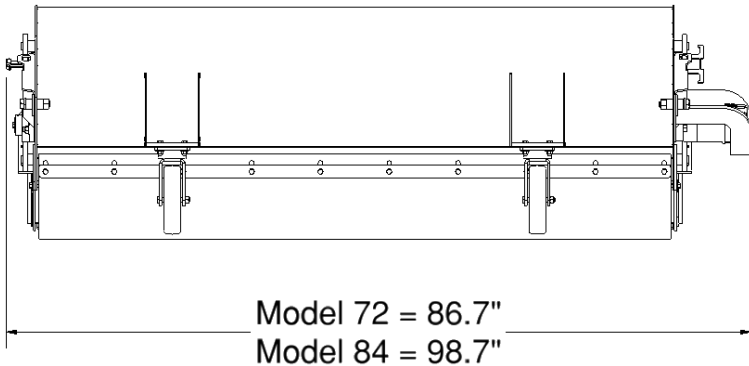

All dimensions are in INCHES.

LIMITED WARRANTY

Erskine Attachments LLC warrants each new machine manufactured by us to be free from defects in material and workmanship for a period of twenty-four (24) months from date of delivery to the original purchaser.

Our obligation under this warranty is to replace free of charge, at our factory or authorized dealership, any part proven defective within the stated warranty time limit.

All parts must be returned freight prepaid and adequately packaged to prevent damage in transit.

This warranty does not cover:

1. New products which have been operated in excess of rated capacities or negligence
2. Misuse, abuse, accidents or damage due to improperly routed hoses
3. Machines which have been altered, modified or repaired in any manner not authorized by our company
4. Previously owned equipment
5. Any ground engaging tools in which natural wear is involved, i.e. tooth tips, cutting teeth, etc.
6. Normal maintenance
7. Fork tines
8. Hydraulic motors that have been disassembled in any manor

In no event will the Sales Representative, Dealership, Erskine Attachments LLC, or any other company affiliated with it or them be liable for incidental or consequential damages or injuries, including but not limited to the loss of profit, rental or substitute equipment or other commercial loss. Purchaser's sole and exclusive remedy being as provided here in above.

Erskine Attachments LLC must receive immediate notification of defect and no allowance will be made for repairs without our consent or approval.

This warranty is in lieu of all other warranties, express or implied by law or otherwise, and there is no warranty of merchantability or fitness purpose.

No agent, employee, or representative of Erskine Attachments LLC has any authority to bind Erskine Attachments LLC to any warranty except as specifically set forth herein. Any of these limitations excluded by local law shall be deemed deleted from this warranty; all other terms apply.

This warranty may not be enlarged or modified in any manner except in writing signed by an executive officer of Erskine Attachments LLC to improve its products whenever it is possible and practical to do so. Erskine Attachments LLC reserves the right to make changes and or add improvements at any time without incurring any obligation to make such changes or add such improvements to products previously sold.

Erskine Attachments LLC
P.O. Box 1083 Alexandria, MN 56308
Phone (218) 435-4045 Fax (218) 435-5293



P/N 350327
9/22/2022
Erskine Attachments LLC

Date Printed:

Printed in U.S.A.