

OPERATOR'S MANUAL

FX Series Skidding Winch

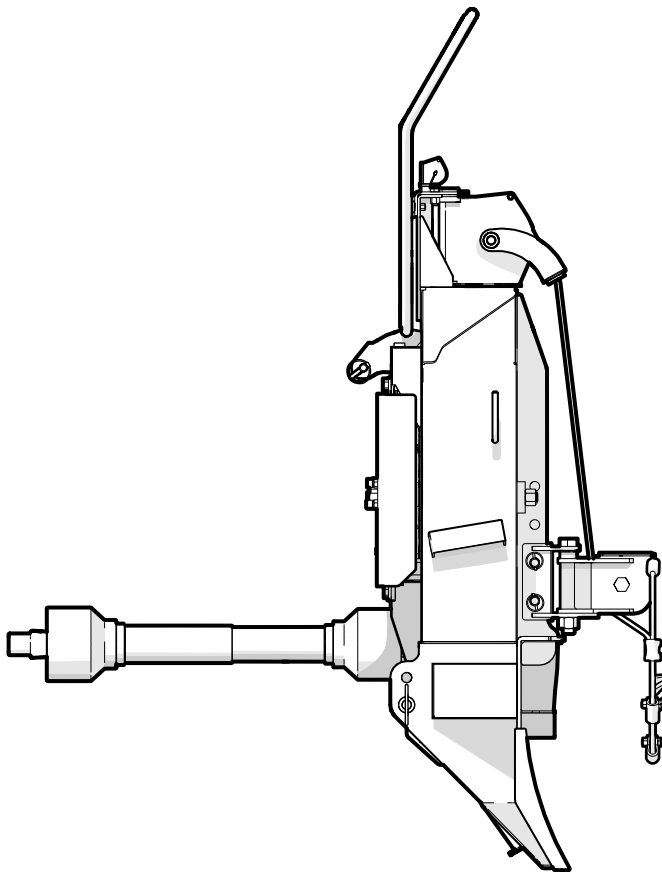

Table of Contents

1. Foreword	3	7. Service and Maintenance	37
1.1 Introduction	3	7.1 Maintenance Safety	37
1.2 Delivery Inspection Report.....	4	7.2 Maintenance Schedule	38
1.3 Serial Number Location	5	7.3 Grease Points	38
1.4 Types of Decals on the Machine	6	7.4 Drive Chain Lubrication	39
2. Safety	7	7.5 Drive Chain Tension	40
2.1 Safety Alert Symbol	7	7.6 Clutch Adjustment.....	40
2.2 Signal Words	7	7.7 Drum Brake Adjustment.....	41
2.3 Why is SAFETY important?	7	7.8 Winch Rope Replacement	42
2.4 Safety Rules	7	7.9 Synthetic Winch Rope Maintenance.....	42
2.5 Operating Safety.....	8	7.10 Brake and Clutch Rope Routing	43
2.6 Equipment Safety Guidelines	9	7.11 Storage	43
2.7 Safety Training.....	9	7.12 Transporting.....	44
2.8 Preparation	9	8. Troubleshooting	45
2.9 Sign-Off Form	11	9. Specifications	47
2.10 Safety Sign Explanations.....	12	9.1 Machine Specifications	47
3. Familiarization	16	9.2 Common Bolt Torque Values.....	48
3.1 To the New Operator	16	9.3 Hydraulic Fitting Torque Values.....	49
3.2 Operator Orientation	16	10. Accessories	50
3.3 Training.....	16	11. Product Warranty	51
3.4 Job Site Familiarization.....	16	12. Index	52
3.5 Equipment Condition	16		
3.6 Winch Components	17		
4. Attaching Winch to Tractor	18		
4.1 Winches with Remote Control	19		
4.2 Sizing PTO Shaft	20		
4.3 Alternate Method	22		
4.4 Installing PTO Shaft.....	23		
5. Controls	24		
5.1 Winch Clutch.....	24		
5.2 Winch Drum Lock	24		
5.3 Forged Cable End.....	24		
5.4 Keyhole Sliders	25		
5.5 Keyhole Slots	25		
5.6 Choker Chains	26		
5.7 Synthetic Chokers.....	26		
5.8 Lower Snatch Block	26		
5.9 Trailer Hitch	27		
5.10 Safety Screen	27		
5.11 Remote Winch Control	27		
6. Operating Instructions	31		
6.1 Pre-start Checks	31		
6.2 Machine Break-In.....	32		
6.3 Winch Safety.....	32		
6.4 Synthetic Winch Rope Safety	33		
6.5 Winch Logs	34		
6.6 Skid Logs	35		

1. Foreword

WARNING!

Do not attempt to start or operate the machine before you read this manual thoroughly. Make sure that you understand how to operate the machine correctly and safely before you use it.

Keep this manual with the machine at all times.

W034

1.1 Introduction

Congratulations on your choice of a Wallenstein PTO-Driven Log Skidding Winch!

FX Series Winches are designed to pull those hard to reach logs, even on steep hills or through swampland.

This manual covers the following FX Series models:

Model	Features
FX85	Manual Control, Steel Winch Rope
FX85R	Remote Control, Steel Winch Rope
FX85S	Manual Control, Synthetic Winch Rope
FX85RS	Remote Control, Synthetic Winch Rope
FX110	Manual Control, Steel Winch Rope
FX110S	Manual Control, Synthetic Winch Rope
FX110R	Remote Control, Steel Winch Rope
FX110RS	Remote Control, Synthetic Winch Rope
FX140	Manual Control, Steel Winch Rope
FX140R	Remote Control, Steel Winch Rope
FX140S	Manual Control, Synthetic Winch Rope
FX140RS	Remote Control, Synthetic Winch Rope

Safe, efficient and trouble-free operation of this Wallenstein product requires that anyone using or maintaining the machine reads and understands the Safety, Operation, Maintenance information contained within this Operator's Manual.

Keep this manual handy for frequent reference and to pass on to new operators or owners. Call your Wallenstein dealer or distributor if you need assistance, information or additional copies of the manuals.

Units of measurement in Wallenstein Equipment technical manuals are written as:
US Customary (SI metric).

Wallenstein Equipment Inc. • © 2022. All rights reserved.

No part of this work may be copied, reproduced, replaced, distributed, published, displayed, modified, or transferred in any form or by any means except with the prior permission of Wallenstein Equipment Inc.



Model Configuration

FX110RS

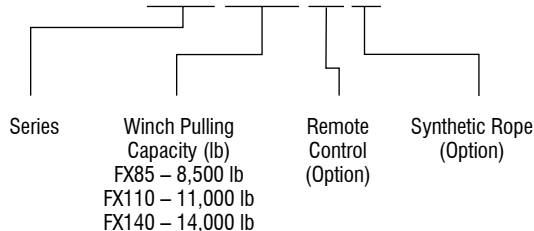

1.2 Delivery Inspection Report

Wallenstein FX Series Logging Winch

To activate warranty, register your product at WallensteinEquipment.com.

This form must be filled out by the dealer and signed by the dealer and customer at the time of delivery.

The product manuals have been received by me and I have been thoroughly instructed as to care, adjustments, safe operation, and applicable warranty policy.

I have thoroughly instructed the buyer on the equipment care, adjustments, safe operation and applicable warranty policy and reviewed the manuals.

Customer

Address

City, State/Province, ZIP/Postal Code

()

Phone Number

Contact Name

Model

Serial Number

Delivery date

Dealer

Address

City, State/Province, ZIP/Postal Code

()

Phone Number

1.2.1 Dealer Inspection Report

_____ Check condition of winch rope / spooled correctly.

_____ Drive chain tension checked

_____ PTO shaft telescopes, is greased. Shield turns

_____ Fasteners tight

_____ Grease zerks, pivot points lubricated

_____ Clutch rope moves freely

_____ Brake rope moves freely

FX85R, FX110R, FX140R

_____ Remote control functions correctly

_____ Clutch hydraulic cylinder functions

_____ Check electrical power connections

_____ Check wiring connections

Safety Checks

_____ All safety decals installed

_____ Guards and shields installed and secured

_____ Retainer installed through hitch points

_____ Review operating and safety instructions

1.3 Serial Number Location

Always provide the model and serial number of your Wallenstein product when ordering parts or requesting service or other information. This information is found on the serial number plate shown in the illustration below.

Record product information in the spaces provided for future reference.

Record Product Information Here	
Model:	
Serial Number:	

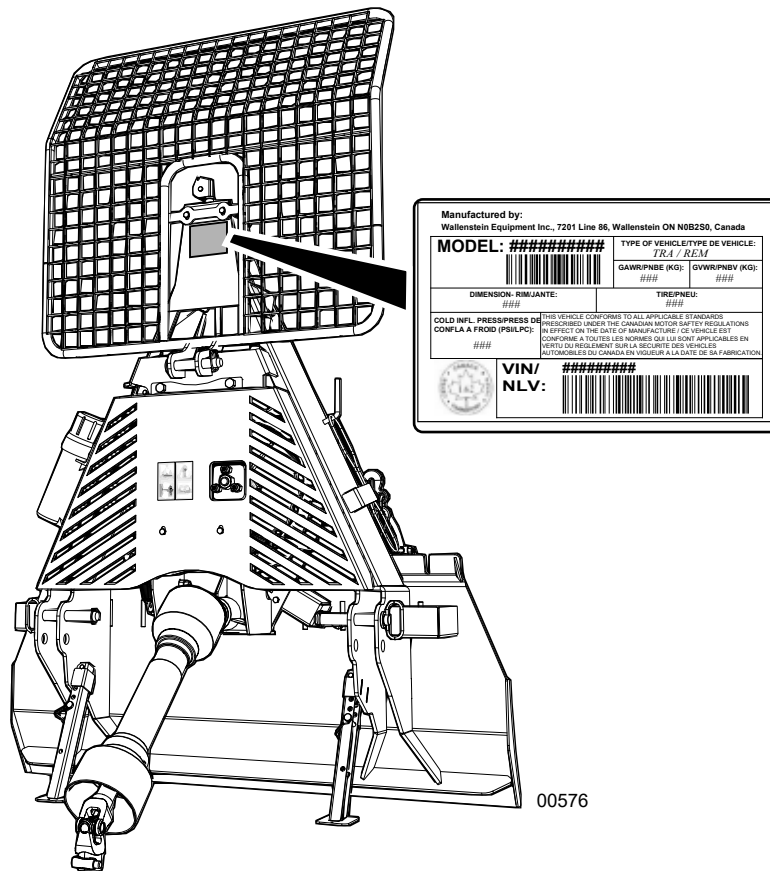
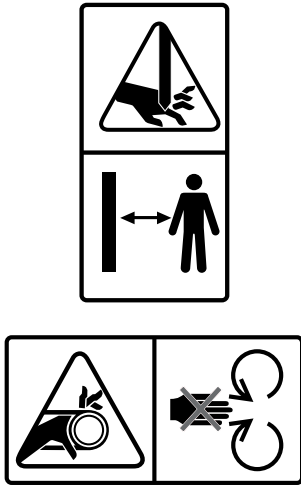

Fig. 1—Serial Number Plate Location

1.4 Types of Decals on the Machine

When getting familiar with the Wallenstein product, notice that there are numerous decals located on the machine. There are different types of decals for safety, information, and product identification. The following section explains what they are for and how to read them.

Safety Decals have a yellow background and are generally two panel. They can be either vertical or horizontal.



Safety Notice Decals are pictorial with a blue background and generally rectangular with single or multiple symbols. This decal informs what Personal Protective Equipment is required for safe operation.



Informative Decals are generally pictorial with a white background and can vary in the number of panels. This type of decal explains the operation of a control.

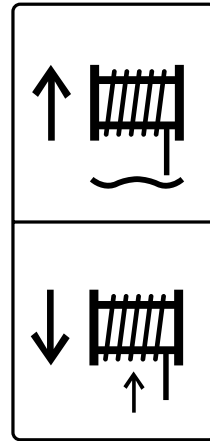

Product Decals indicate machine model and serial number, and other important information.

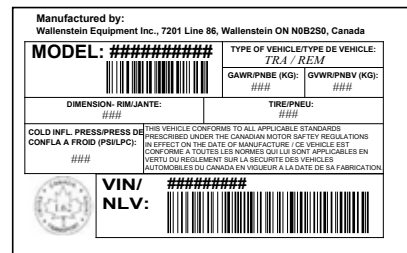

See the section on safety signs for safety decal definitions. For a complete illustration of decals and decal locations, download the parts manual for your model product at WallensteinEquipment.com.

2. Safety

2.1 Safety Alert Symbol

This Symbol means:

**ATTENTION! BE ALERT!
YOUR SAFETY IS INVOLVED!**

The Safety Alert Symbol identifies important safety messages on the Wallenstein product and in the manual.

When you see this symbol, be alert to the possibility of personal injury or death! Follow the instructions in the safety message.



2.2 Signal Words

The signal words **DANGER**, **WARNING** and **CAUTION** determine the seriousness level of the warning messages in this manual. The appropriate signal word for each message in this manual has been selected using the following guidelines:

DANGER –

Indicates an imminently hazardous situation that, if not avoided, **will** result in death or serious injury. This signal word is to be limited to the most extreme situations typically for machine components which, for functional purposes, cannot be guarded.

WARNING –

Indicates a potentially hazardous situation that, if not avoided, **could** result in death or serious injury, and includes hazards that are exposed when guards are removed. It may also be used to alert against unsafe practices.

CAUTION –

Indicates a potentially hazardous situation that, if not avoided, **may** result in minor or moderate injury. It may also be used to alert against unsafe practices.

IMPORTANT – To avoid confusing equipment protection with personal safety messages, a signal word **IMPORTANT** indicates a situation that if not avoided, could result in damage to the machine.

2.3 Why is SAFETY important?

Three Big Reasons:

- Accidents Disable and Kill
- Accidents Cost
- Accidents Can Be Avoided

YOU are responsible for the SAFE operation and maintenance of your Wallenstein Log Skidding Winch. **YOU** must make sure that anyone who is going to use, maintain or work around the winch is familiar with the operating and maintenance procedures and related **SAFETY** information contained in this manual.

Remember, **YOU** are the key to safety. Good safety practices not only protect you but also the people around you. Make these practices a working part of your safety program. Be certain that **EVERYONE** using this equipment is familiar with the recommended operating and maintenance procedures and follows all the safety precautions. Most accidents can be prevented.

Do not risk injury or death by ignoring good safety practices.

2.4 Safety Rules

- **DO** give operating instructions to operators or employees before allowing them to operate the machine.



- **DO** always wear appropriate Personal Protective Equipment (PPE). This equipment includes but is not limited to the following:
 - A hard hat
 - Heavy gloves
 - Hearing protection
 - Protective shoes with slip resistant soles
 - Protective glasses, goggles or face shield



- **DO** set the machine in a Safe Condition before performing any service, maintenance work, storage preparation, or hooking up. **Safe Condition** involves performing the following:

SAFE CONDITION
<ol style="list-style-type: none"> 1. Disengage the PTO. 2. Set the parking brake. 3. Turn tractor engine off. Remove the ignition key. Block the tractor wheels. 4. Make sure all components have stopped moving. 5. Check winch rope is not under tension.

- **DO** have a first-aid kit available for use should the need arise and know how to use it.



- **DO** read and learn all safety signs located on the machine before using, maintaining, adjusting or cleaning the winch.
- **DO** inspect and secure all guards before starting.
- **DO** have a fire extinguisher available for use should the need arise and know how to use it.



- **DO NOT** expect a person who has not read and understood all use and safety instructions to operate the machine. An untrained operator is not qualified and exposes himself and bystanders to possible serious injury or death. It is the owner's responsibility to the operator to make sure familiarity and understanding of the machine.
- **DO NOT** modify the equipment in any way. Unauthorized modification may impair the function and/or safety and could affect the life of the equipment.
- **DO NOT** allow riders during transport.
- **DO NOT** risk injury or death by ignoring good safety practices.

2.5 Operating Safety

- Understand the meaning of the safety signs on the machine. Keep them clean. Replace them if they become damaged.
- Never operate this winch with guards or shields removed. The manufacturer has designed this skidding winch to be used with all its safety equipment properly attached, to minimize the chance of accidents.
- Read and understand the operator's manual before starting. Review safety instructions annually.
- Do not allow anyone within 20 ft (6 m) of machine or logs during operation.
- Stand at least 10 ft (3 m) to the side to activate the winch.
- Do not touch or stand directly in line with rope during operation.
- Check rope condition before using winch. Rope can break if it is kinked, corroded, knotted, or has broken strands. Replace if damaged.
- Never consume alcohol or take drugs that could hinder alertness or coordination while operating this equipment. Consult a doctor about operating this machine if taking prescription medications.
- Do not allow riders on this machine at any time. There is no safe place for any riders.
- Keep rear tractor wheels on level ground and lower winch blade when winching to provide stability.
- Do not exceed winching angle of more than 25° off center.
- Always winch up a slope. It is not safe to winch down slope. Logs could roll unpredictably. Do not winch across a slope.
- If the winch is equipped with a synthetic rope, always use a choker chain. NEVER wrap the rope around the log or hook the forged end back onto the rope. The rope can be damaged and break.

- Replace synthetic rope if kinked, badly frayed, has knots, cuts, or broken strands. If rope fails under tension it can snap back with great force causing injury or death. Avoid sudden jerks, quick starts or stops. Start slowly and smoothly.
- Do not operate on hillsides or when working area is cluttered, wet, muddy or icy to prevent slipping and tripping.
- Keep all components of PTO systems shielded and guarded.
- Regularly test driveline guards by spinning or rotating them to make sure they have not become stuck to the shaft.
- Disengage the PTO and shut off the tractor before dismounting to clean, repair, service, or adjust machinery.
- Walk around tractors and machinery rather than stepping over a rotating shaft.
- Do not exceed a safe travel speed when transporting.

2.6 Equipment Safety Guidelines

- Keep all shields in place. If shield removal becomes necessary for repairs, replace the shield prior to use.
- Replace any safety sign or instruction sign that is not readable or is missing. Location of such safety signs are indicated in this manual on page 12.
- Do not modify the equipment in any way. Unauthorized modification may result in serious injury or death and may impair the function and life of the equipment.
- Never exceed the limits of the machine. If its ability to do a job is in question, or to do so safely – **STOP!**

2.7 Safety Training

- Safety is a primary concern in the design and manufacture of our products. Unfortunately, our efforts to provide safe equipment can be wiped out by a single careless act of an operator or bystander.
- The best safety feature is an informed, careful operator—we ask you to be that kind of an operator. It is the operator's responsibility to read, understand and follow ALL safety and operation instructions in the manual. Review *page 12*.



- Working with unfamiliar equipment can lead to careless injuries. Read this manual before assembly or using the machine to acquaint yourself with it. If this machine is used by any person other than yourself, or is loaned or rented, it is the machine owner's responsibility to make certain that prior to using, the operator:
 - reads and understands the owner's manual
 - is instructed in safe and proper use of the equipment
 - understands and knows how to perform the Safe Condition procedure
- Train all new personnel and review instructions frequently with existing workers. Be certain only a properly trained and physically able person will use the machinery. Anyone not familiar with operation and safety instructions is not qualified to use the machine. An untrained operator exposes himself and bystanders to possible serious injury or death. If the elderly are assisting with the work, their physical limitations need to be recognized and accommodated.
- Know your controls and how to stop the machine quickly in an emergency. Read this manual thoroughly.

2.8 Preparation

- Never use the machine until the operators have been adequately trained in the safe operation of the machine and have read and completely understand:
 - safety, operation and feature sections of this manual
 - each of the safety messages found on the safety signs on the machine.
 - engine operator's manual
- PPE is recommended during assembly, installation, operation, adjustment, maintaining, repairing, removal, cleaning, or moving the trailer. Do not allow long hair, loose fitting clothing or jewelry around equipment.
- Prolonged exposure to loud noise may cause permanent hearing loss! Power equipment with or without equipment attached can often be noisy enough to cause permanent, partial hearing loss. We recommend that you wear hearing protection on a full-time basis if the noise in the Operator's position exceeds 80 dB. Noise over 85 dB on a long-term basis can cause severe hearing loss. Noise over 90 dB adjacent to the Operator over a long-term basis may cause permanent, total hearing loss.
- Be aware of overhead hazards: branches, cables, electrical wires.
- Use only in daylight or good artificial light.
- Make sure that all safety shielding and safety signs are properly installed and in good condition.



- Perform the **Pre-start Checks** procedure before starting work (see *page 18*).
- Replace any hydraulic hose immediately that shows signs of swelling, wear, leaks or damage before it bursts.
- Do not bend or strike high-pressure lines, tubes or hoses, or reinstall them in a bent or damaged condition.
- Check to make sure hydraulic hoses are not worn or damaged, and are routed to avoid chafing.
- Never adjust a pressure relief valve or other pressure-limiting device to a higher pressure than specified.

2.10 Safety Sign Explanations

Safety signs on the equipment are explained in the pages that follow.

Working safely requires familiarizing yourself with the various safety signs, the type of warning and the area, or particular function related to that area, that requires your SAFETY AWARENESS.

IMPORTANT! If parts are replaced that have safety signs on them, new signs must be applied. Safety signs must always be replaced if they become damaged, are removed, or become illegible.

Safety signs are included in the product decal kit available from your authorized dealer. Decals are not available separately.

Think SAFETY! Work SAFELY

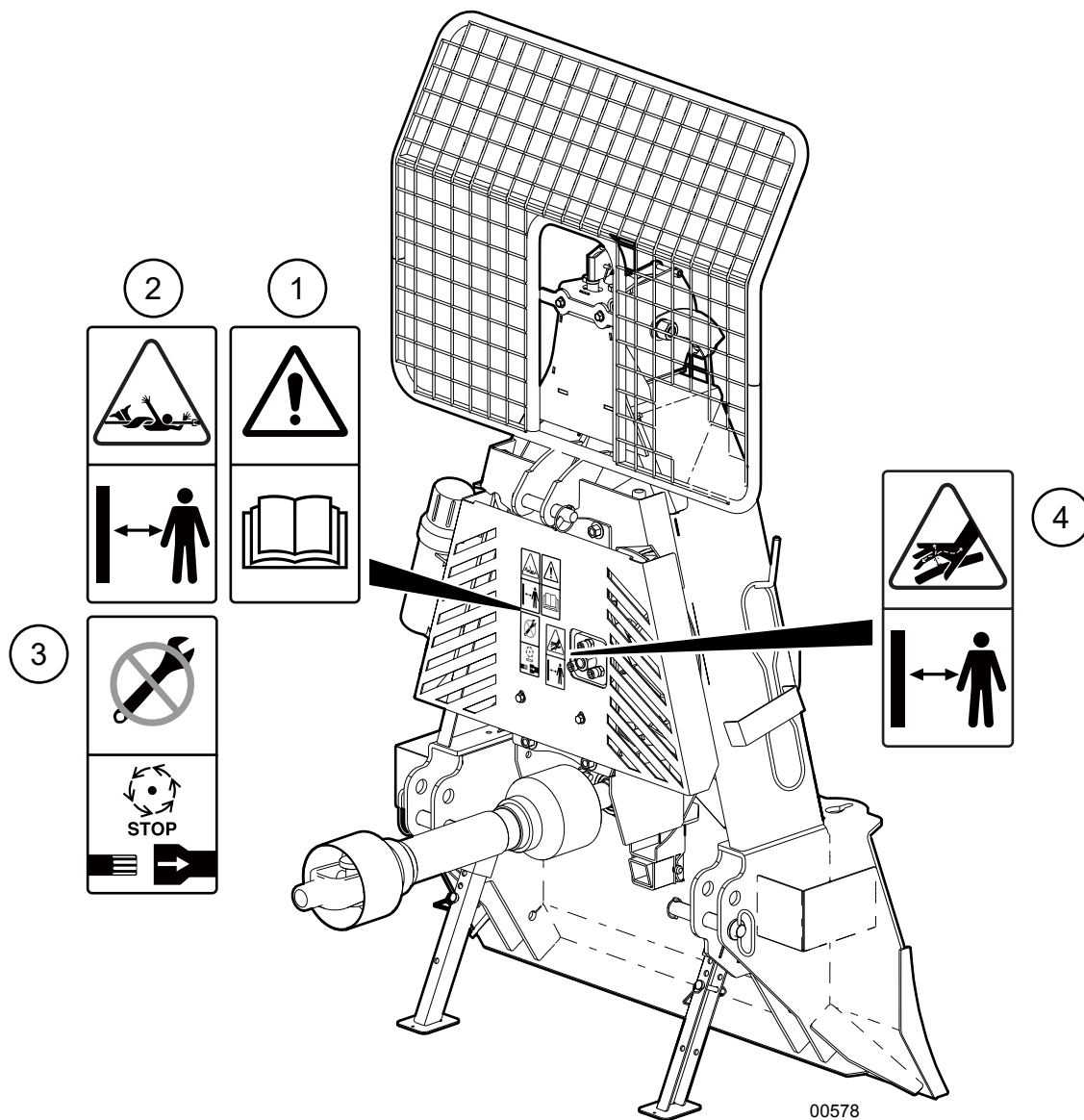

Fig. 2 –FX-Series Safety Decal Placement

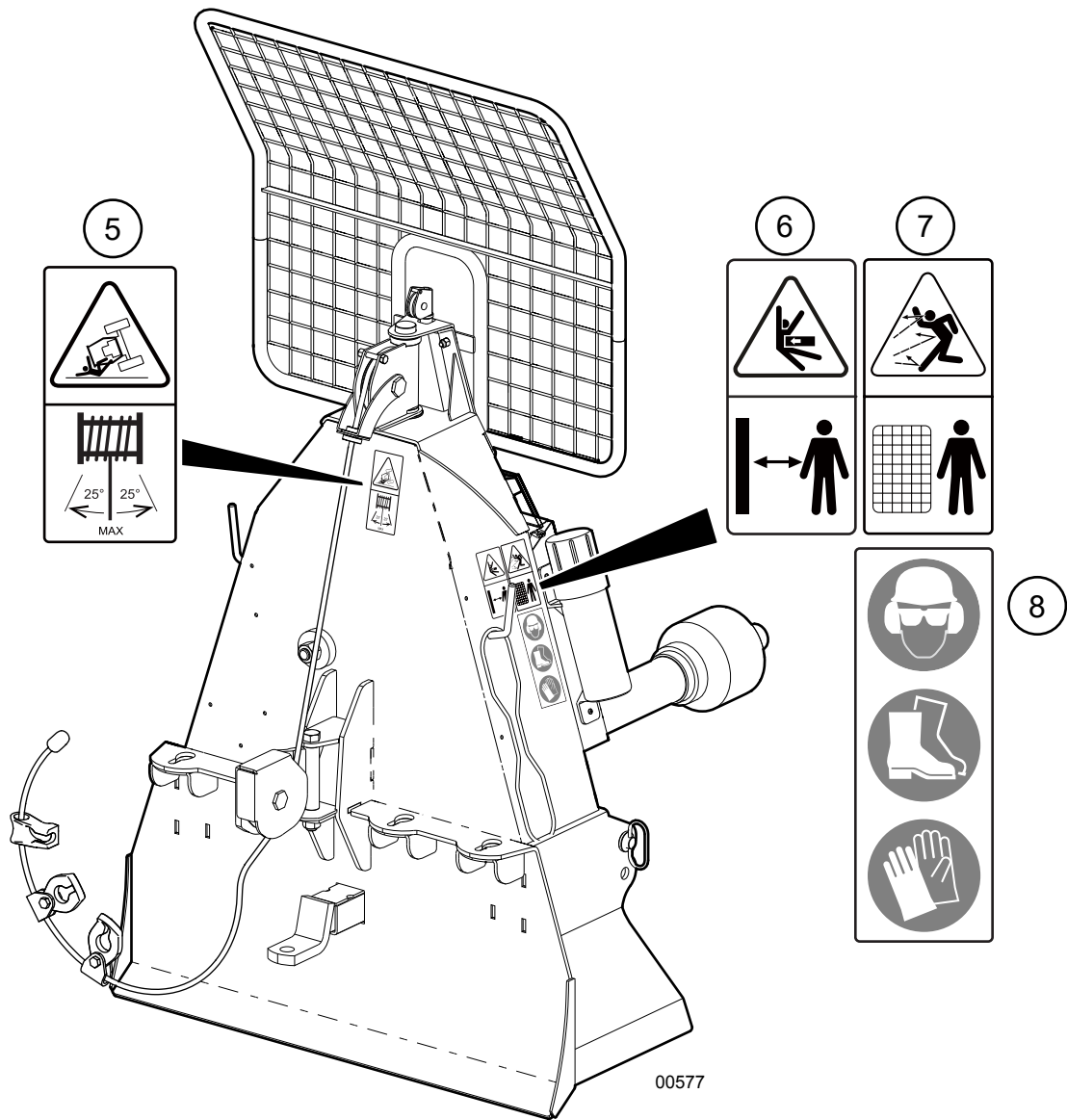
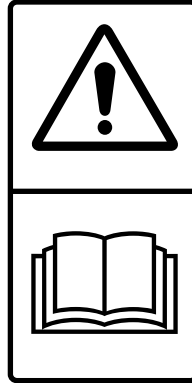

Fig. 3 – FX-Series Safety Decal Placement

1. Caution!

Refer to the operator's manual. Read ALL operating instructions in the manual and learn the meaning of ALL safety signs on the machine.

The best safety feature is an informed operator.



4. Warning!

Concealed hydraulic fluid connection under pressure.

Use caution when removing panels or guards. Do not check for leaks with your hand or fingers when the system is pressurized. Serious injury can result.

(R-models only, equipped with remote control)



2. Warning!

Risk of entanglement from rotating driveline.

Keep hands, loose clothing, and long hair away from driveline while it is rotating.

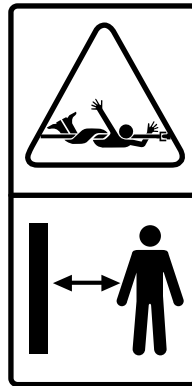

5. Warning!

Risk of tractor overturning.

Do not operate with the winch rope angle greater than 25° off center, in either direction.

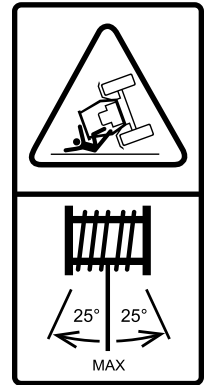

3. Warning!

Risk of injury when servicing or repairing this machine.

Disconnect the driveline before working on this machine.

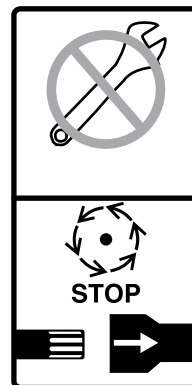

6. Warning!

Crushing hazard.

Do not stand in front of the winch when using it. Stand to the side at a minimum 10 ft (3 m) away.



7. Warning!

Be aware of the risk of injury from flying objects. Stay behind the protective screen when possible. Rope could release from a log unexpectedly and snap back fast enough to cause injury.

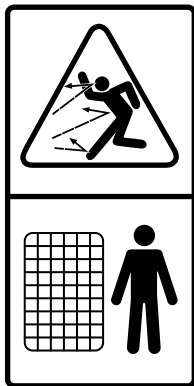

8. Warning!

Always wear appropriate Personal Protective Equipment when using this machine. For example:

- A hard hat
- Heavy gloves
- Hearing protection
- Protective shoes with slip resistant soles
- Protective glasses, goggles or face shield



IMPORTANT! If parts are replaced that have safety signs on them, new signs must be applied. Safety signs must always be replaced if they become damaged, are removed, or become illegible.

Safety signs are included in the product decal kit available from your authorized dealer. Decals are not available separately.

2.10.1 Replacing Damaged Safety Signs

- Always keep safety signs clean and legible.
- Replace safety signs that are missing or have become illegible.
- Parts that were replaced with a safety decal on them must also have the safety sign replaced.
- Replacement safety signs are available from your authorized Distributor, Dealer Parts Department, or Wallenstein Equipment.

Procedure

1. Be sure that the installation area is clean and dry.
2. Be sure temperature is above 50 °F (10 °C).
3. Determine exact position before removing from the backing paper.
4. Pull the decal off the backing sheet, align the sign over the specified area, then carefully press the exposed sticky backing in place.
5. Use a piece of the backing paper to smooth the decal out, pressing from the center outwards.
6. Small air pockets can be pierced with a pin and smoothed out using the piece of sign backing paper.

3. Familiarization

IMPORTANT! Before starting work with the winch, become familiar with the location and function of all controls.

3.1 To the New Operator

It is the responsibility of the owner or operator to read this manual and to train all other operators before they start working with the machine. Follow all safety instructions exactly.

By following recommended procedures, a safe working environment is provided for the operator, bystanders and the area around the work site. Untrained operators are not qualified to use the machine.

3.2 Operator Orientation

IMPORTANT! When describing controls as mentioned throughout this manual, the directions for left-hand, right-hand, backward and forward, are determined when sitting in the tractor seat, facing the direction of forward travel.

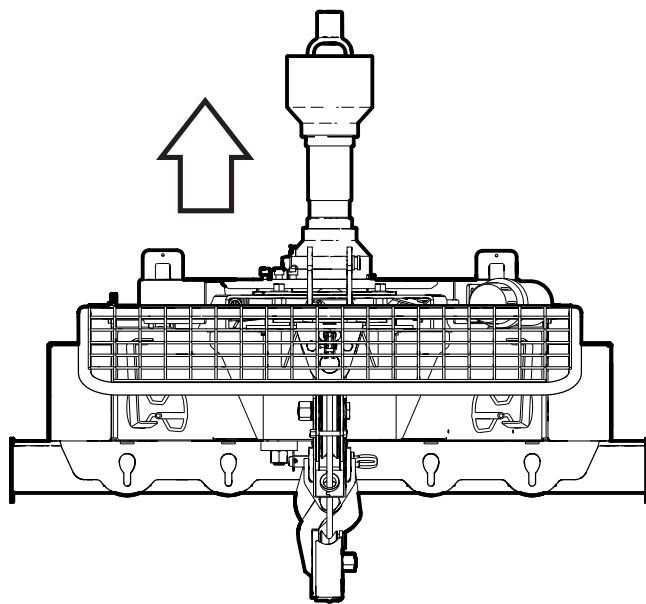

Fig. 4—Direction of forward travel

3.3 Training

Each operator must be trained in the proper set-up and operating procedures prior to being allowed to operate the machine.

1. Review control location, function and movement directions.
2. Move the unit to a large open area to allow the operator to become familiar with control function and machine response.
3. When a new operator is familiar and comfortable with the machine, they can proceed with the work. Do not allow untrained operators to use the machine. They can endanger themselves and others or damage property and the machine.

3.4 Job Site Familiarization

It is the responsibility of the operator to be thoroughly familiar with the work site prior to starting. Prevent the chance or possibility of problems or accidents by not being in the situation to start with. Some items the operators should check include but are not limited to:

1. Close or cramped work space. Be sure there is sufficient space and clearance for the machine to winch-in the log during operation.
2. Organize the working area to minimize the winching and wood removal distances. The shorter the distances, the faster the work will be finished.
3. Use care when pulling logs from a pile as they can roll when attaching the rope or winching.
4. Position the tractor so prevailing winds blow engine exhaust fumes away from operator.

3.5 Equipment Condition

1. Periodically check the general condition of the winch. Make sure that all nuts and bolts are secure and that a moveable parts are secured and in their proper place.
2. Always inspect the rope as it is pulled out of the winch. Do not use the machine if the rope is cut, frayed, worn or knotted. Any problem can result in early failure and create an unsafe operating condition. Replace damaged rope before resuming work.

3.6 Winch Components

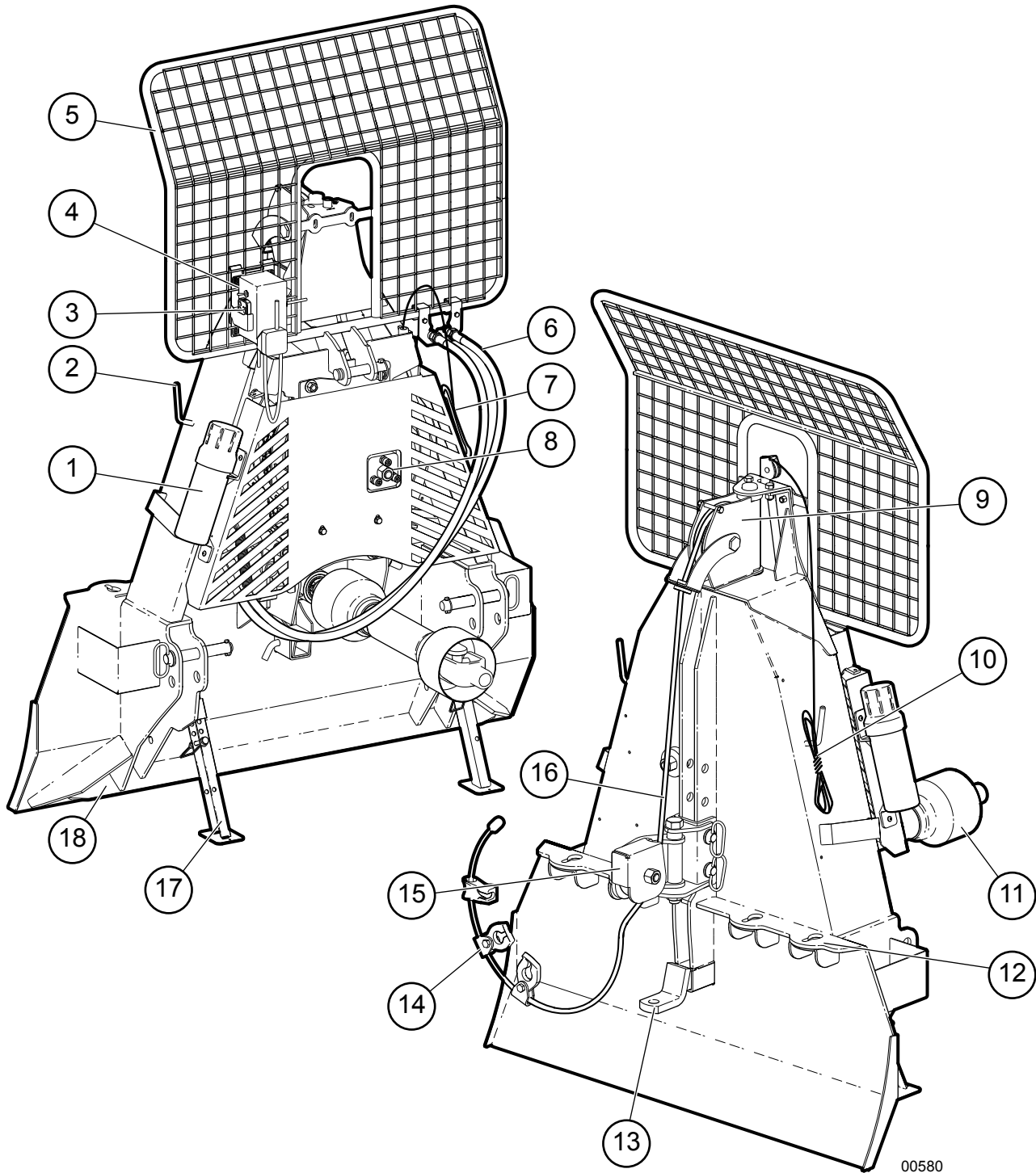

00580

Fig. 5—Winch Components

- | | |
|--|--|
| 1. Operator's Manual Canister | 10. Winch Clutch Rope (white) |
| 2. Chain Hook | 11. PTO Shaft |
| 3. Remote Control Transmitter (R-Models) | 12. Chain Tow Bar |
| 4. Remote Control Receiver (R-Models) | 13. Draw Bar (FX85/R, FX110/R, FX140/R models) |
| 5. Safety Screen | 14. Key Hole Sliders (FX85/R, FX110/R, FX140/R models) |
| 6. Hydraulic Hoses (R-Models) | 15. Snatch Block |
| 7. Drum Lock Rope (green) | 16. Wire Rope (Synthetic Rope on S-Models) |
| 8. Clutch Adjuster | 17. Support Legs |
| 9. Top Cable Pulley | 18. Anchor Blade |

4. Attaching Winch to Tractor

- FX85/R winches are Category I.
- FX110/R, FX140/R winches are Category II.
- All winches are three-point hitch mount, and not Quick Hitch or iMatch™ compatible.

WARNING!

Never let anyone stand between the tractor and the implement during hitching. Too fast of an approach or the operator's foot slipping from the clutch can lead to injury or fatality to the person standing nearby.

W048

Before hooking the winch up to the tractor, make sure PTO shaft length is correct. If the length has not been checked, see page 20.

IMPORTANT! For safety and maximum PTO life, PTO shaft should be as level as possible when the winch is in the lowered, working position.

 **NOTE:** R-models are equipped with the remote winch control and require 1–2 gpm hydraulic flow and a 12 VDC power source.

Make sure there is enough room and clearance to safely back the tractor up to the winch.

1. Move the tractor drawbar forward for clearance, if required.
2. Place the tractor lift arms in their full sway position. Remove the hitch pins from the winch.
3. At the slowest speed, back the tractor up keeping it lined up with the winch.
4. When reversing, raise or lower the lift arms to align them to the hitch pin holes on the winch.

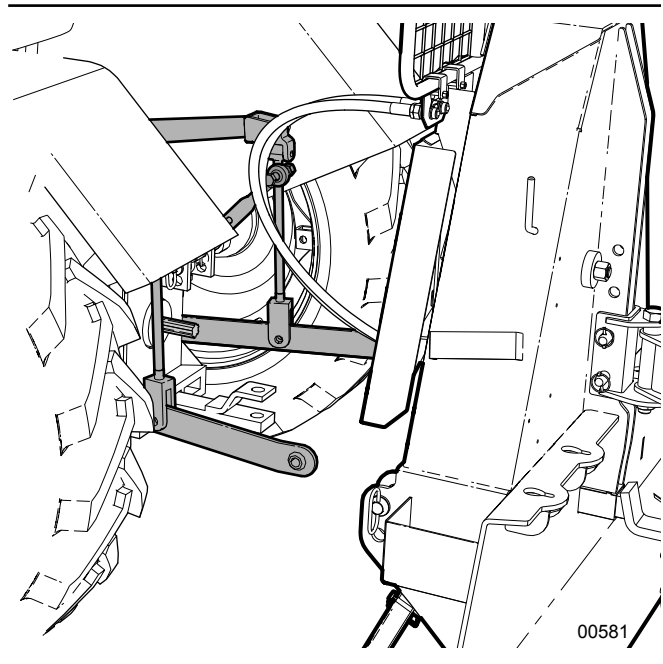

Fig. 6—Align Tractor to Winch

5. Once properly aligned, apply the tractor park brake and turn the engine off.
6. Slide a hitch pin through the lower lift arm holes and hitch pin holes on both sides. Install the lynch pin retainers on each pin.

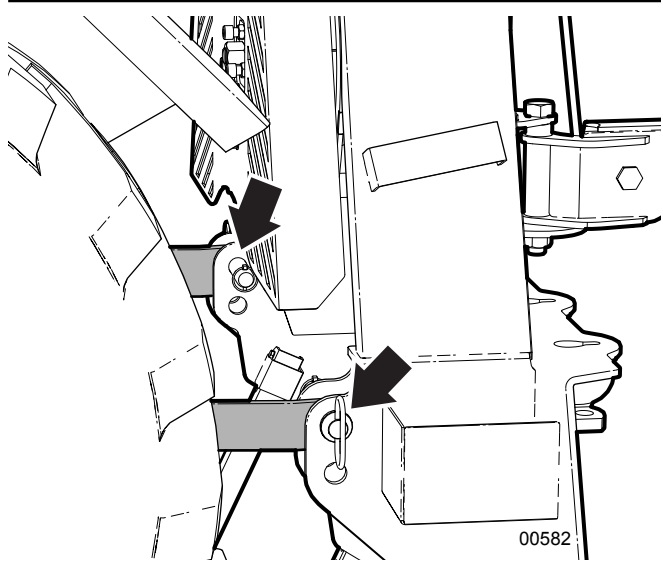

Fig. 7—Hitch Pins Installed

7. Remove the top pin and install the top link.
8. Adjust turnbuckle to align the top link. Insert the hitch pin and retainer. Adjust so the winch is level.

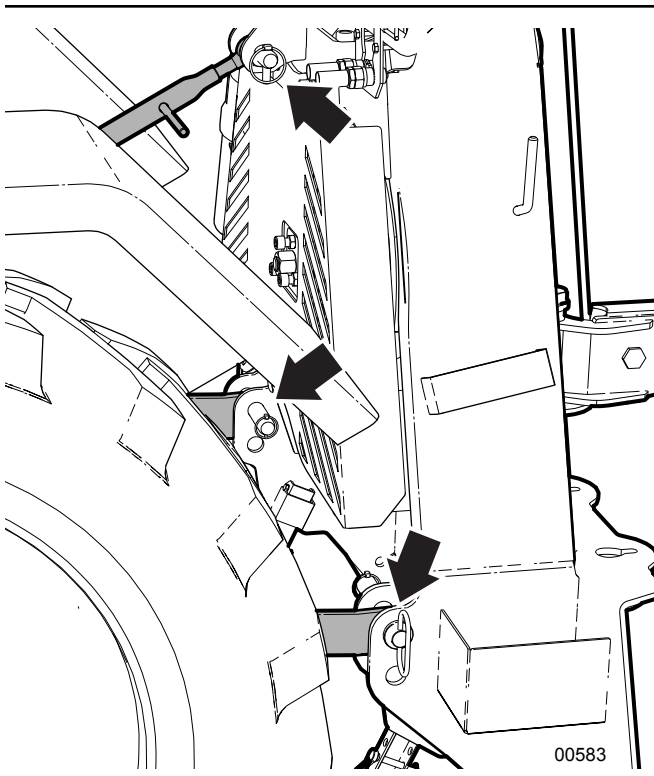

Fig. 8—Winch Attached

9. Slide the collar back on the PTO shaft yoke. Align the splines and slide the yoke on the tractor PTO.
10. Release the collar and make sure the locking pin clicks into position.
11. Attach the shield anchor safety chain to an adjacent frame member. The chain keeps the integral journal shield from spinning.

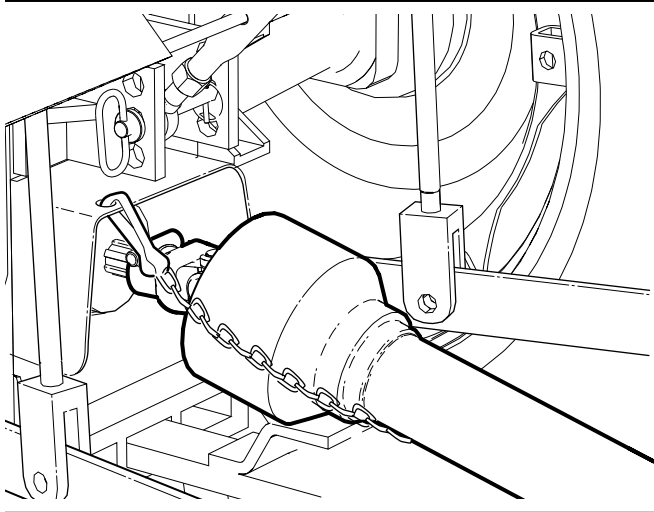

Fig. 9—PTO Shaft Installed

12. Raise winch support legs to the storage position. Insert snap lock pins.

13. Start the tractor and slowly raise the machine up through its working range to make sure the telescoping portion of the PTO shaft does not bottom out.

To detach winch from the tractor, reverse the above steps.

4.1 Winches with Remote Control

FX85R, FX110R and FX140R models include a wireless remote winch control. The system consists of a hand-held transmitter control and a receiver mounted on the winch.

For the remote to function, the following electrical and hydraulic connections to the winch must be made.

Electrical Connection

- A **12 VDC, 1.5 amp** power source is required from the tractor electrical system.
- The white wire from the receiver should be connected to positive, black to ground.
- Connectors are not supplied on the wire ends. Wire ends are supplied bare to permit different adaptations.

Hydraulic Connection

- A valve on the winch controls the winch clutch. The system is designed for an open-center hydraulic system. Oil flow required is **1–2 gpm (3.8–7.5 L/m)**. This oil flow rate provides the best starting/stopping speeds to prolong rope life.
- The 1/2" pressure and return hoses have quick-disconnect ends and are connected to the tractor rear remote power supply.
- The hoses have colored, protective caps to indicate function. Red is pressure and blue is return.



In the event pressure and return hoses are not identifiable, check the connection on the control valve. 'R' is indicated on the return port. 'P' is indicated on the pressure port.

4.2 Sizing PTO Shaft

IMPORTANT! The PTO shaft that came with your machine may need to be shortened. A longer shaft is supplied because tractor lift arms vary in length.

The PTO shaft must be free to telescope and not bottom out when going through its working range. It should never completely collapse in use. There should always be 2" (50 mm) of space for retract.

If the shaft bottoms out, the bearings on both ends can be overloaded and could fail causing damage or injury.

WARNING!

Avoid the risk of personal injury or machine damage! Read the operator's manual before using the equipment. Carefully read all safety messages in the manual and follow all safety signs on the machine.

CAUTION!

Wear suitable eye protection when cutting steel tubes.

Remove the PTO shaft and mount the attachment on the tractor three-point hitch.

1. Start the tractor and raise the three-point hitch up off the ground until the machine's input shaft is level with the tractor PTO output shaft. **This is the shortest distance between the input and output shafts.**
2. Make sure tractor is shut off with parking brake applied.
3. Pull the PTO shaft apart and place one end on the tractor *output* spline. Place the other on the implement *input*.

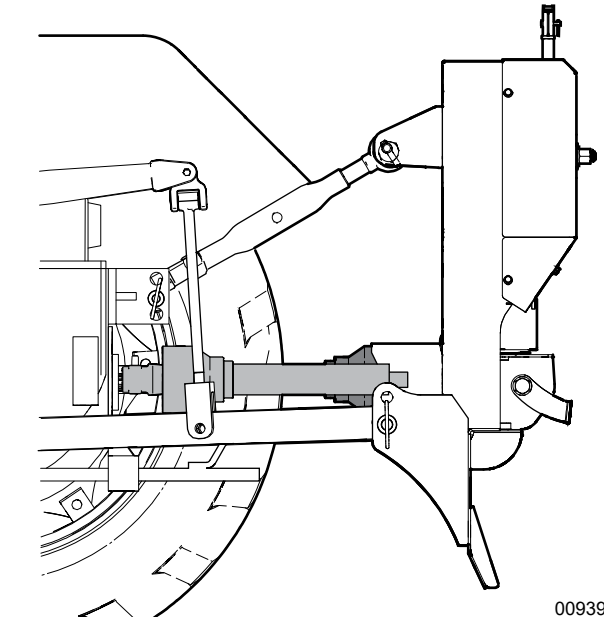

Fig. 10—Input shaft and output shaft

4. Lift the shaft ends up so that they are as parallel to each other as possible. Support them with blocking or tie them together. If the shafts are too long or there is not enough room, see Alternate Method on page 4.

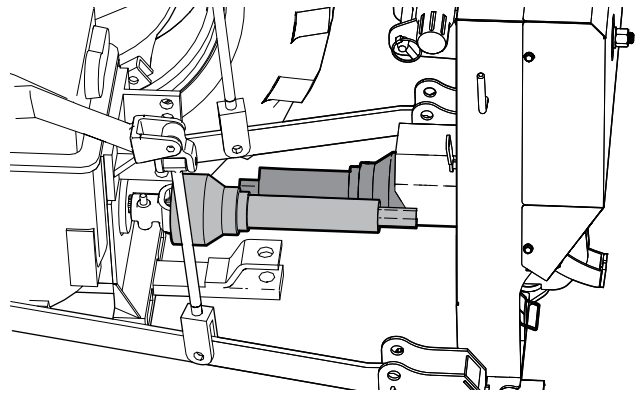

Fig. 11—Lift shaft ends up parallel

- Using a straight edge, transfer a mark from the end of one tube section to the other section as shown.

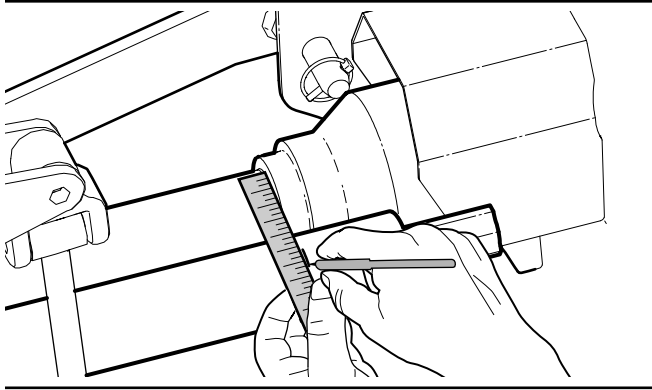

Fig. 12—Transferring the mark

- Add 2 inches (50 mm) to that measurement and place a second mark on the outer plastic tube. This is where the plastic shielding needs to be cut off.

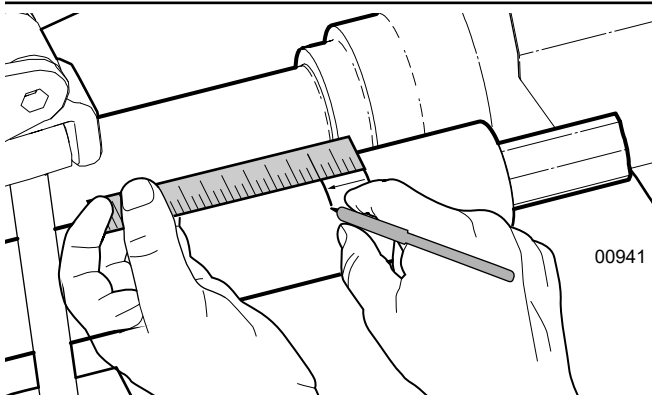

Fig. 13—Place mark to cut plastic tube

- Cut the plastic tube off at the mark, leaving the steel shaft inside.

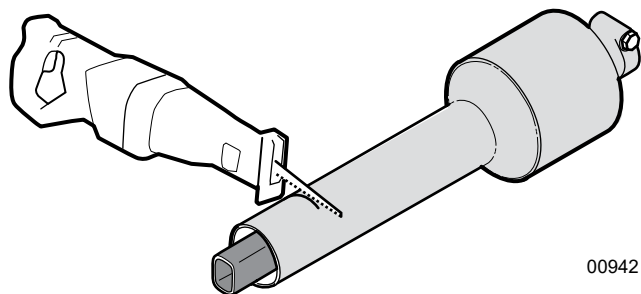

Fig. 14—Cut plastic tube at the mark

- Using the cut-off length of plastic tube as a guide, mark the steel tube. Align the end of the plastic tube with the end of the steel shaft.

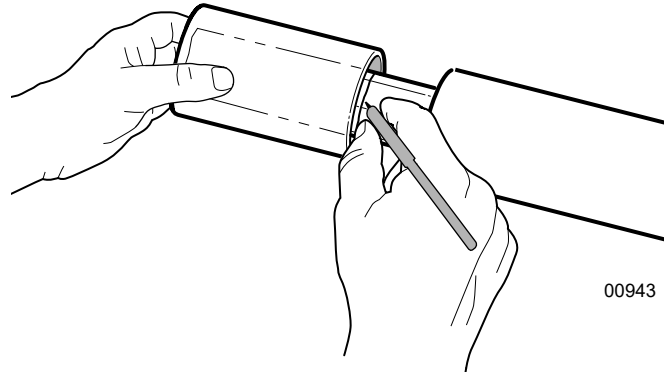

Fig. 15—Marking steel tube.

- Cut the steel tube off at the mark.
- Using the cut-off length of plastic tube to mark the remaining cuts, repeat this process for **BOTH** PTO shaft halves.



Place the end of the steel shaft to be cut off in a vice so it is easier to control your cut.

- Remove the burrs from the edges of the steel shaft that were cut. Clean the steel shaft halves.
- Grease the inner tube so the tube halves slide together easier.

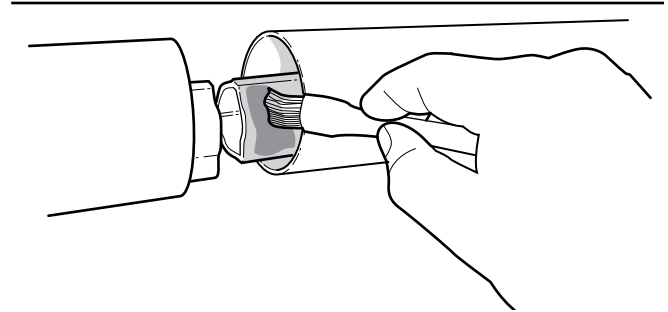

Fig. 16—Grease the inner tube

- Assemble the two halves of the PTO shaft.

IMPORTANT! Using a driveshaft not supplied with your machine may result in being assembled out of phase (universal joint yokes are not aligned with each other). Make sure driveshaft is assembled with u-joints in phase otherwise unbalances cause wear and eventually lead to failure.

- Make sure the shaft can telescope freely before installing. If it does not, separate the two parts and inspect for burrs or cuttings on the shaft ends.

IMPORTANT! The two PTO shaft halves should overlap inside at least 6" (150 mm).

4.3 Alternate Method

This method can be used if the two ends of the PTO shaft cannot be put close enough together to measure.

1. Install the attachment on the tractor. Lift the attachment up so that the tractor output is level with implement input shaft.
2. Take the PTO shaft that came with your machine, fully collapse it, and measure the distance between the locking yokes. Call this measurement 'A'.

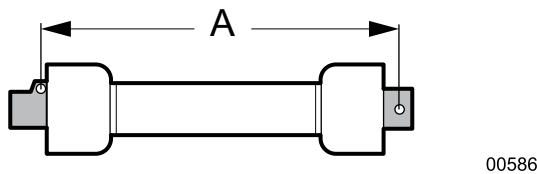

Fig. 17 – Measurement A

3. Measure the distance between the grooves for the locking collars on each input. Subtract 2 inches (50 mm) from this measurement. Call this measurement 'B'.

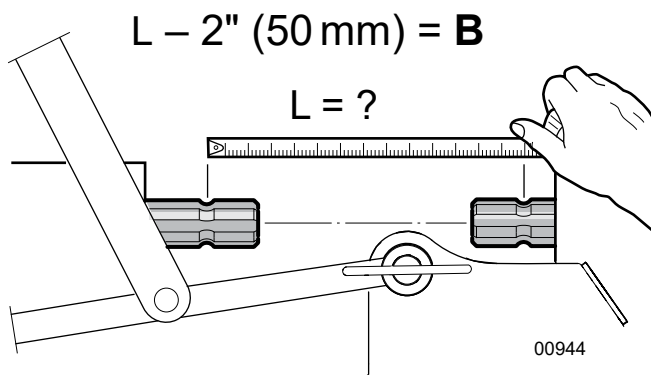

Fig. 18 – Measurement B

4. If the collapsed length **A** is longer than measurement **B** from Step 3, the PTO shaft must be shortened.
5. Subtract **B** from the uncut PTO shaft measurement **A**. ($A - B$)

The result is how much **BOTH** halves of the PTO shaft need to be shortened. Call this value **C**.

$$A - B = C$$

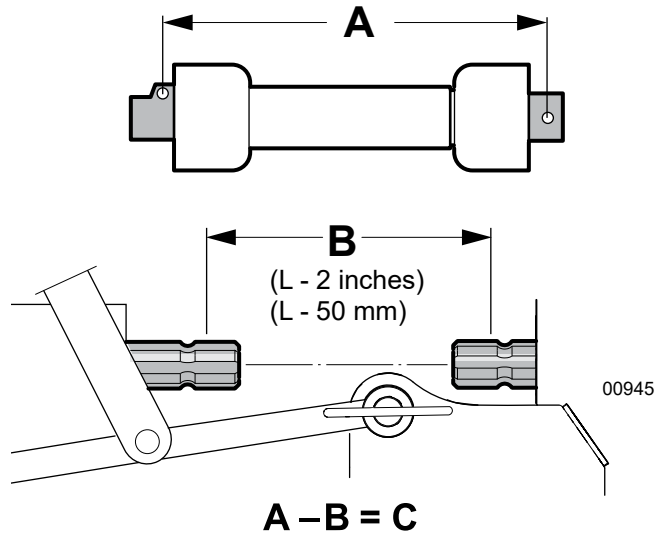

Fig. 19 – C = Cut Length

6. Pull the PTO shaft apart, then measure and cut the length **C** from both the outer plastic covers and the inner metal tubes.



Tip: Use the cut off piece of outer shielding to mark the inner tube. Leave the steel center tubes longer than the plastic outer tubes, otherwise they can be harder to put back together.

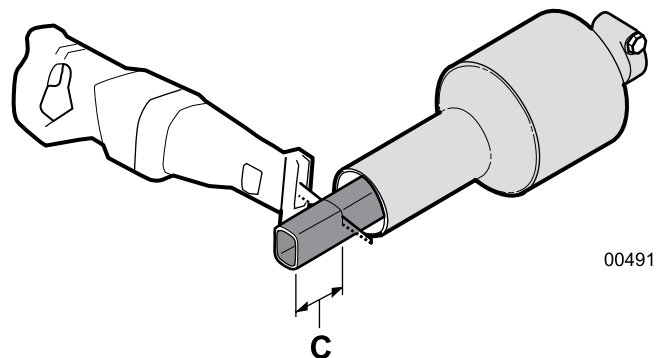

Fig. 20 – Cut off the Length C from both PTO Shaft halves

4.4 Installing PTO Shaft

The implement must be mounted to the tractor, and fully lowered to the ground. Make sure tractor is shut off with parking brake applied.

Check to make sure the shielding on the PTO shaft is in good condition and able to turn freely, independent of the PTO shaft.

Make sure the PTO yoke ends are clean. Adding a small amount of lubricant on the splines can help them slide on.



A decal on the shielding indicates the tractor-end of the driveshaft.

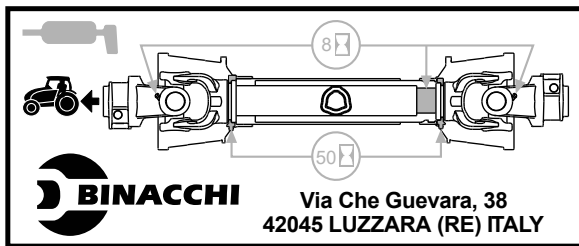

01655

1. Install the PTO shaft on the implement. Press the locking pin button and push the shaft end onto the input PTO. Connect the safety chain to the implement so that the shielding does not turn during operation.

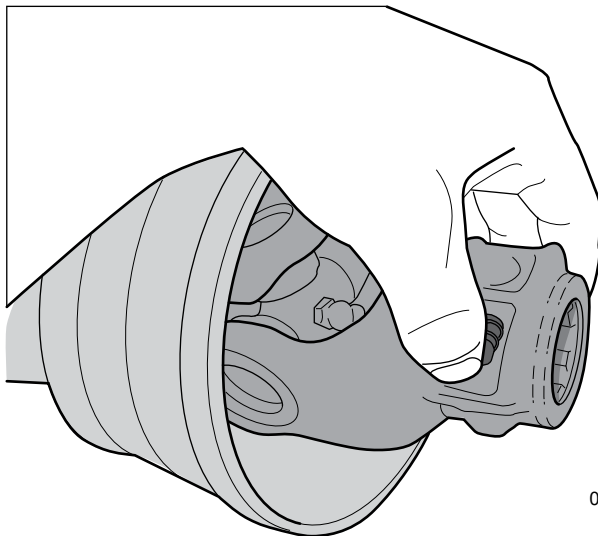

00866

Fig. 21 – Locking Pin Button

2. Slide out the end of the PTO shaft up to the tractor output PTO, aligning the two shaft splines. Press the locking pin button and push the shaft end onto output PTO.
3. Once started, slide the shaft all the way on. You might hear a click and your button should retract to the original position.

4. To check that the shaft lock is fully seated, pull back on the shaft with your hands off the button.
5. Start the tractor and raise / lower the attachment to check clearances. A correctly sized shaft should never bottom out or come apart.

IMPORTANT! Check driveshaft alignment. During operation, the working angle should not be greater than 15° between the tractor and the implement. Misalignment can cause premature wear and eventually failure.

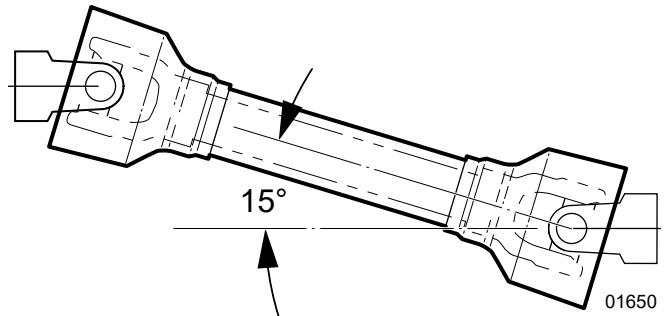

Fig. 22 – Driveshaft Alignment

6. Check the rotation direction. A decal on the machine indicates correct rotation.

5. Controls

5.1 Winch Clutch

The clutch control rope runs through a swivel pulley at the top of the winch allowing it to be operated from any angle.

The winch clutch is engaged by pulling the white winch clutch control rope (1). Relaxing the rope disengages the clutch.

- Pull the rope out firmly to engage the clutch and retract winch rope.
- Release the rope to disengage.

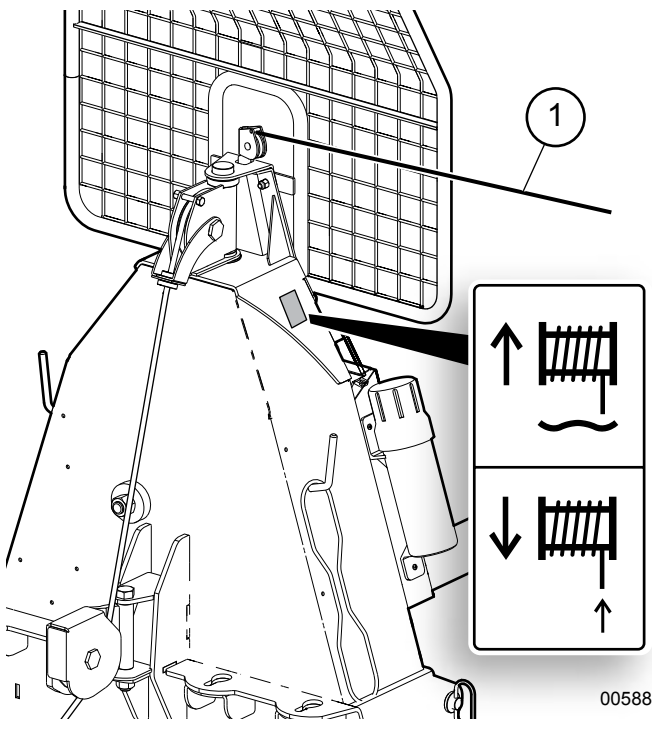

Fig. 23—Winch Clutch

5.2 Winch Drum Lock

Lock the winch drum to prevent the rope unwinding while skidding.

5.2.1 Engaging Drum Lock

- Pull sharply on the green winch lock rope (2). The latch engages on the cogged winch drum.
- While the tractor is moving forward, pressure is applied to the latch and it remains engaged, so the rope can be relaxed.

With the winch drum locked, and the machine can tow or pull a load.

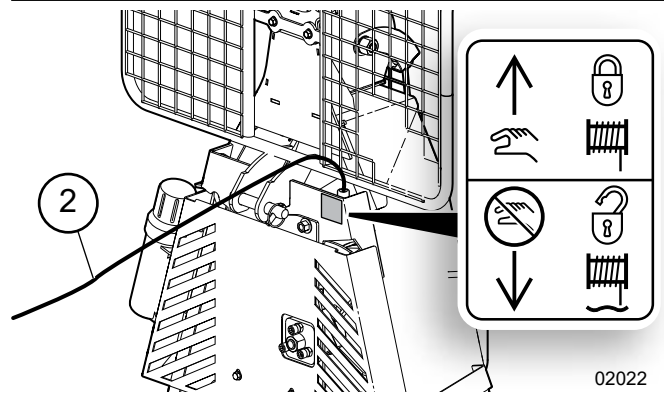

Fig. 24—Drum Lock

NOTE: The latch may disengage if the tractor stops moving forward.

5.2.2 Disengaging Drum Lock

- To disengage the drum lock, stop the tractor or momentarily engage the clutch. Tension is relieved from the latch and the drum releases.
- With the drum lock disengaged, the winch then can freespool. Rope can be pulled out.

5.3 Forged Cable End

The standard steel rope has a heavy duty forged steel end and choker.

- Wrap the rope end around a log and set the forged cable end into the choker.

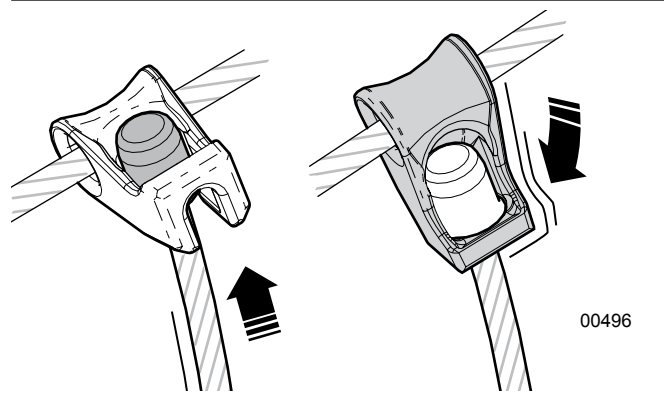
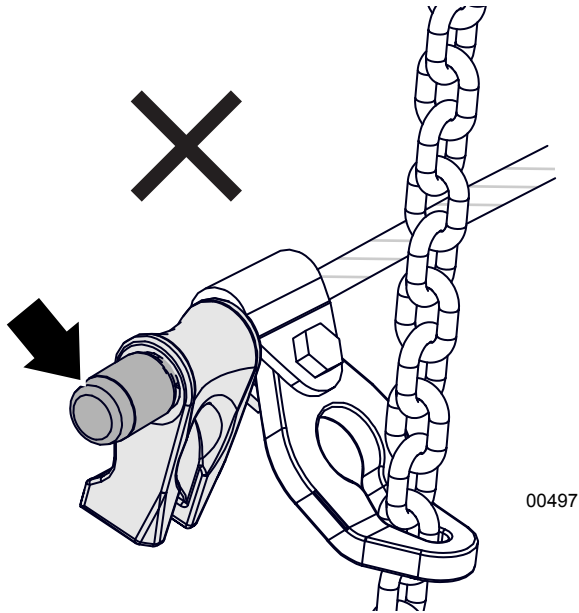

Fig. 25—Forged Cable End

IMPORTANT! Do not use the forged end ferrule on the cable as an end stop.

The ferrule is designed to be used in the choker hook only. The end ferrule can be damaged if used incorrectly.



00497

Fig. 26—Incorrect use of Forged End

5.4 Keyhole Sliders

The standard wire rope has two keyhole sliders that are used to attach the choker chain to the winch rope.

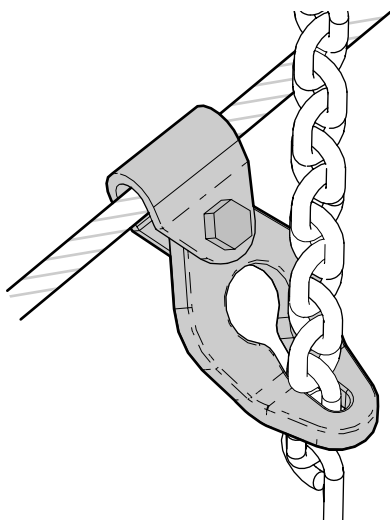

00498

Fig. 27—Keyhole Sliders

Synthetic rope option has two keyhole sliders with a forged hook end.

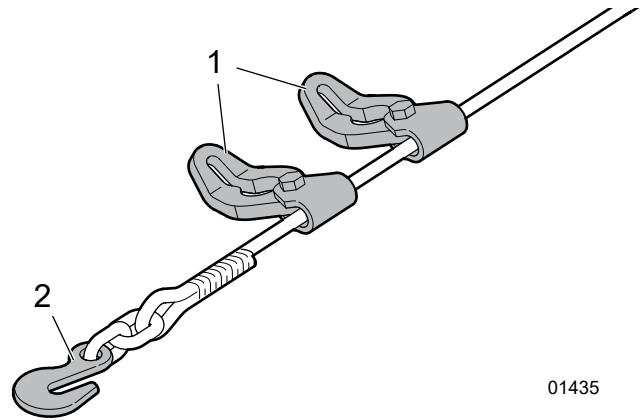

01435

Fig. 28—Synthetic Rope

1. Keyhole Sliders
2. Forged Hook End

IMPORTANT! If the winch is equipped with a synthetic rope, always connect the hook end to a choker chain. Never wrap the synthetic rope around a log or attach the hook end onto the synthetic rope. Incorrect use of the synthetic rope causes damage that is not covered by warranty.

5.5 Keyhole Slots

The chain tow bar is on the back of the winch. Keyhole slots can be used to attach a chain for skidding additional logs.

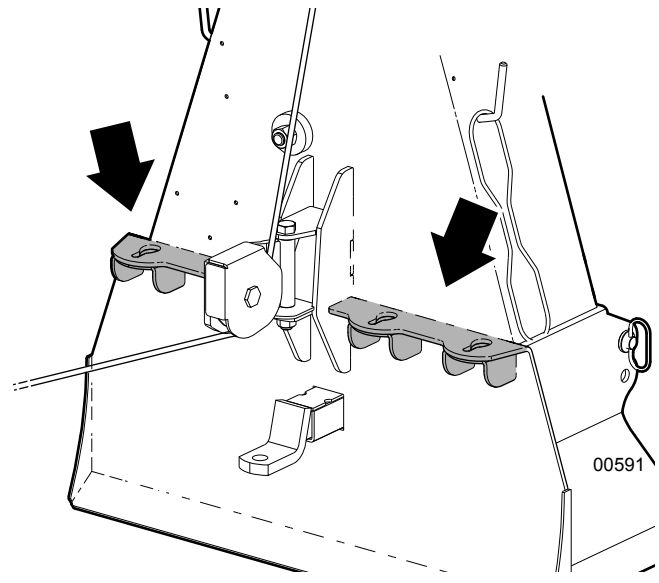

00591

Fig. 29—Keyhole Slots

5.6 Choker Chains

All winches are equipped with two choker chains. The heavy duty 5/16" choker chains are 7-1/2 ft (2.3 m) long with a steel probe for sliding under logs.

- Push the probe end of the choker chain under the log.
- Pull the ends together and put the hook end over the choker chain.
- Attach the probe end of the choker chain to the keyhole slider on the rope.

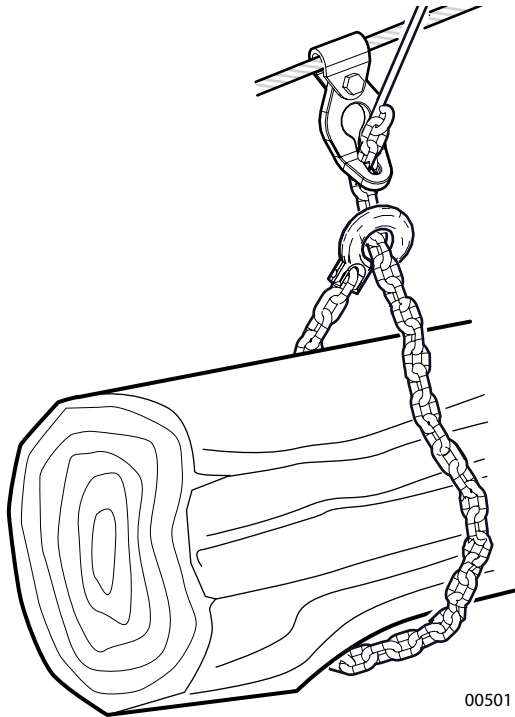

Fig. 30—Choker Chain

IMPORTANT! If the winch is equipped with a synthetic rope, always connect the hook end to a choker chain. Never wrap the synthetic rope around a log or attach the hook end onto the synthetic rope. Incorrect use of the synthetic rope causes damage that is not covered by warranty.

5.7 Synthetic Chokers

Synthetic chokers are available as an accessory. These chokers weigh less than the steel chain chokers and are easier to handle, however are more susceptible to abrasion.

Before each use, check the condition of the choker for visible damage. Replace if kinked, frayed, has knots, cuts, or any broken strands. Failure to replace could result in breakage.

⚠ WARNING!

Synthetic rope that fails under tension can snap back with great force causing injury or death. Avoid sudden jerks, quick starts or stops. Start slowly and smoothly. Replace if kinked, badly frayed, has knots, cuts, or broken strands.

W095

- Push the probe end of the choker under the log.
- Pull the ends together and push the probe end through the loop.
- Attach the chain on the probe end to the keyhole slider on the cable.

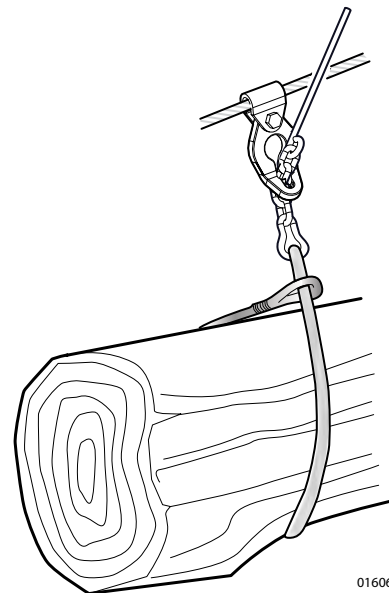

Fig. 31—Synthetic Choker

- A synthetic choker is very susceptible to damage from rubbing up against or sliding along rough ground or surfaces.
- Synthetic choker strength can be reduced if subjected to sudden jerking, or quick starts and stops. Avoid high shock loads on the rope by starting slowly and smoothly.

5.8 Lower Snatch Block

All models have a lower snatchblock. The main use of the lower snatchblock is to lower the pulling point, and make skidding more stable. This enables larger loads to be skidded. The snatchblock has three positioning holes on the FX110 and FX140.

When finished winching, the rope is moved to the lower snatchblock for skidding out the load. To use it, give the rope some slack and tuck it behind the snatch block onto the pulley.

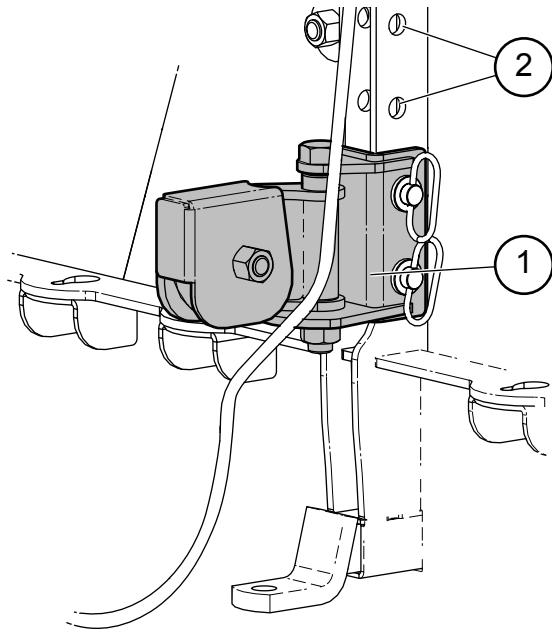

00592

Fig. 32—Snatchblock

1. Snatchblock Assembly
2. Position Holes (FX110, FX140 models)

5.9 Trailer Hitch

All models come with a heavy-duty ball hitch that fits into the 2-inch square receiver on the winch frame.

The trailer hitch is held in with a pin and clip.

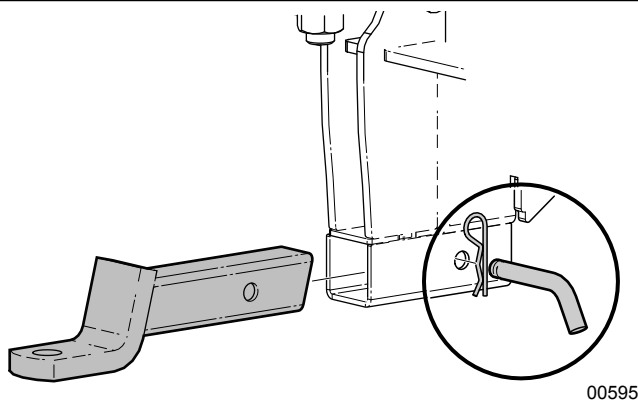

00595

Fig. 33—Trailer Hitch

5.10 Safety Screen

Each machine is equipped with a safety screen that protects the operator from flying chips, twigs branches, and rope recoil in the unlikely event of breakage when skidding or winching. Always keep the safety screen in good condition.

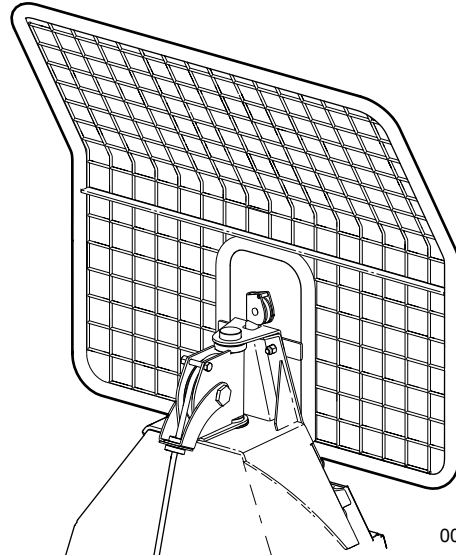

00596

Fig. 34—Winch Safety Screen

5.11 Remote Winch Control

(FX85R, FX110R, FX140R)

The remote winch control provides a means of engaging/disengaging the spring-loaded clutch at a distance from the winch.

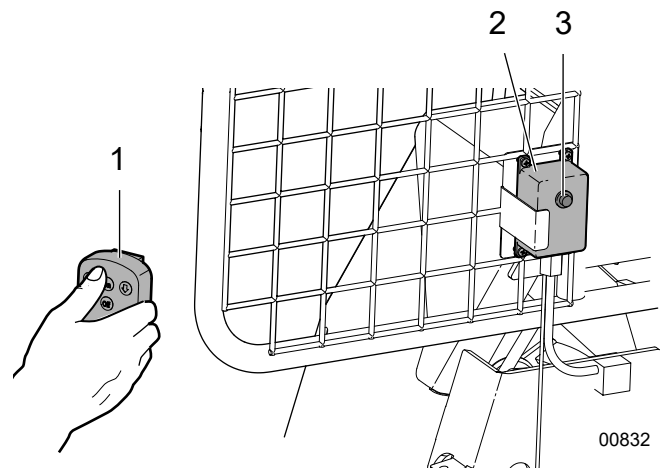

00832

Fig. 35—Remote Winch Control System

1. Hand-held Transmitter
2. Receiver
3. Manual Override Switch

5.11.1 Hand-held Transmitter



- **Never leave a transmitter unattended.**
- **Always switch the transmitter off when not in use. Store in a safe place.**
- **Keep a clear view of the work area at all times.**

W054

Each transmitter is pre-programmed with a unique code. The receiver is programmed to respond only to that transmitter. Other radio-controlled systems can therefore work in close proximity without interference.

The transmitter has two replaceable 1.5 V, AAA non-rechargeable alkaline batteries. The batteries are accessed by removing the rear panel.

IMPORTANT! Do not recharge the batteries. Attempts to recharge may cause rupture or hazardous liquids to leak, causing damage to the equipment.

There are three LED indicators on the transmitter. The (center) green LED flashes to indicate communication between the transmitter and the receiver. The red LEDs flash to indicate low battery or a system error.

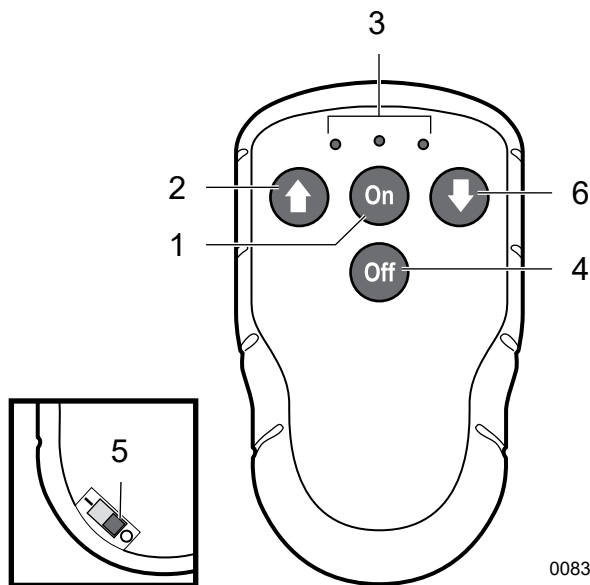

00830

Fig. 36—Hand-held Transmitter

1. Power ON Button
2. Clutch Engage Button
3. LED Indicator Lights
4. Power OFF Button
5. I/O Switch
6. (not used)

Power On (1)



Push to turn on the transmitter.

Clutch Engage (2)



Push and hold to activate the winch (retract the cable). The transmitter sends a signal to the receiver once pressed. The winch stops when the button is released.

LED Indicator lights (3)

These LEDs indicate system status. The center LED is green during normal operation. When 10% of battery life remains, it lights red. The left- and right-hand LEDs are red and come on to indicate a system error.

Power Off Button (4)



Push to turn the transmitter off.

I/O Button

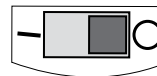

The I/O Button on the back of the transmitter disconnects the power supply from the batteries. The switch must be in the 'I' position for the transmitter to operate. In the 'O' position, the transmitter cannot be used.

When storing the winch for a period of time, the switch should be moved to the 'O' position to save battery life. Turn the switch to the 'O' position when changing batteries.

IMPORTANT! Do not use the I/O button to start or stop the transmitter. Use the On and Off buttons instead.

5.11.2 Receiver

The receiver is mounted on the winch safety screen. The signal from the transmitter to the receiver is sent to the hydraulic actuator to engage/disengage the winch clutch. It requires a 12 VDC power connection from the tractor. The receiver enclosure is weather, vibration and shock resistant.

A manual override switch on the receiver permits engaging/disengaging the winch clutch in the event the transmitter is not functioning.

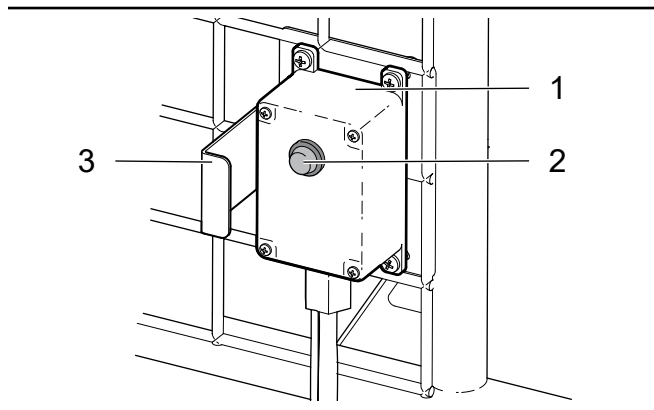

Fig. 37 – Receiver

1. Receiver
2. Manual override button
3. Storage mount for transmitter

5.11.3 Manual Override

The winch can be operated manually with the button on the front of the receiver.



Do not risk personal injury by standing in front of the winch during operation. Do not use manual override unless winch operation is necessary and the remote is not functioning.

W050

Because of the location of the switch, the manual override control must not be used on a continuous basis and should only be used until the remote is back in service. Be aware of the rope and load to avoid potential injury.

5.11.4 Transmitter Operation



Press and hold the ON button until the green LED turns on, then release. The green LED flashes rapidly when communication has been established with the receiver. It flashes slowly if the receiver is off or there is no communication between the transmitter and receiver.



Press and hold the UP arrow to retract the winch cable.

Release the button to disengage the winch and stop the cable retracting.

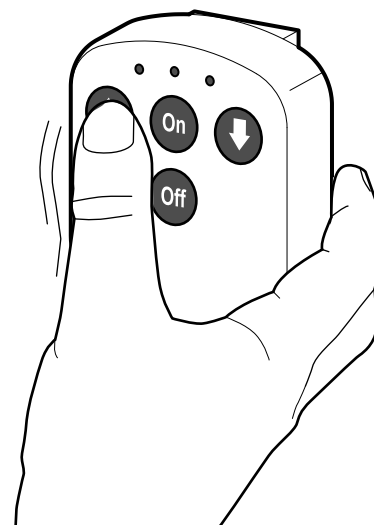

00833

Fig. 38 – Remote Transmitter operation



NOTE: *With the UP button released (clutch disengaged), the winch drum can freespool so cable can be pulled out.*

5.11.5 Automatic Shutdown

The transmitter shuts down automatically after three minutes of inactivity.

5.11.6 Synchronizing Transmitter and Receiver

In the event it is necessary to synchronize a new transmitter and receiver, use the following steps:

1. Remove the cover from the receiver.
2. On the circuit board, press the small receiver Function (F) button. The function LED lights red.

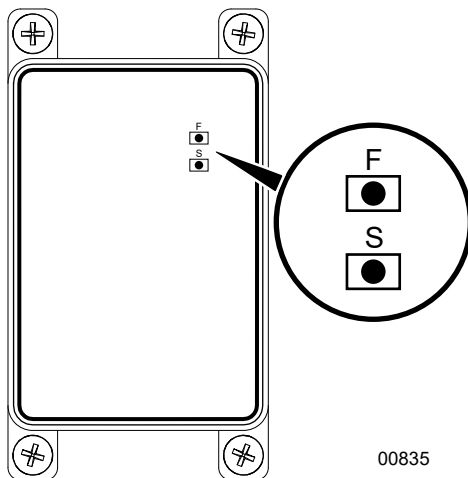

Fig. 39—Receiver Function and Select Buttons

3. Press the receiver Select (S) button just below the Function Button. The relay LEDs light red.
4. On the transmitter, press and hold the up and down arrows simultaneously. The LEDs inside the receiver then flash three times to acknowledge the signal is being received.
5. Release the buttons on the transmitter. The relay LEDs flash red once indicating receiver and transmitter are now synchronized. If no transmitter is found within approximately 10 seconds, the receiver exits to normal operation.

5.11.7 Erasing all Transmitters from the Receiver

In the event it is necessary to erase a transmitter from the receiver, follow these steps:

1. Press the receiver Function (F) button. The function LED lights red.
2. Press the receiver Select (S) button. Keep pressed at least 4 seconds. All relay LEDs light red then go off.
3. Release the receiver Select (S) button. All transmitters are now erased from the receiver.

If the function LED flashes red, one or more transmitters are still registered in the receiver and the above procedure needs to be repeated.

6. Operating Instructions

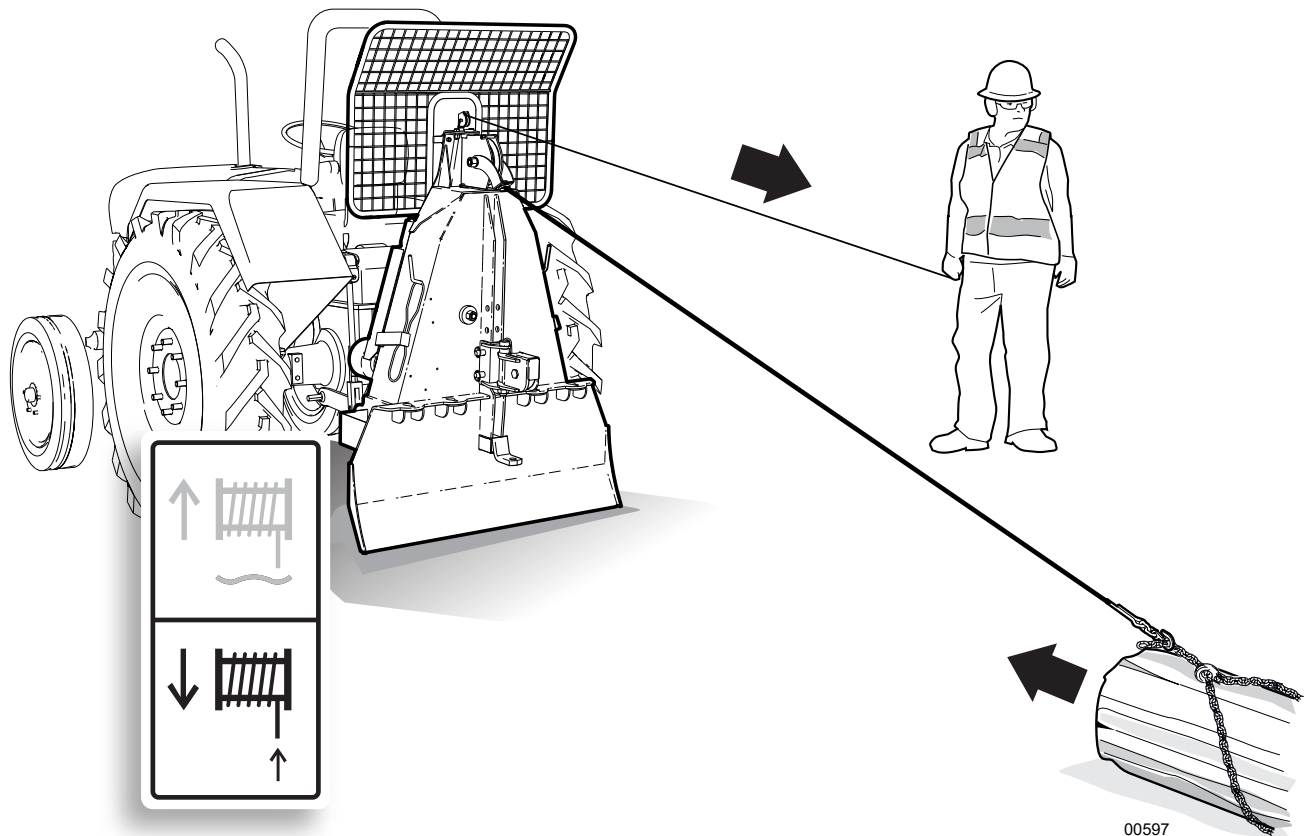

Fig. 58 – Winching Operation – Manual

6.1 Pre-start Checks

Before operating the winch, perform the following pre-start checks.

A Pre-start Checklist is provided for both personal safety and to keep the winch in good mechanical condition.

Item to Check	✓
Check that the integral plastic journal shield on the PTO shaft can spin freely.	
Check and lubricate the PTO shaft following the schedule outlined in the Maintenance section.	
Check the condition of the winch rope for visible damage. Replace if kinked, frayed, has knots, cuts, or any broken strands. Failure to replace could result in breakage. For synthetic rope, see page 33.	
Check the condition of the winch clutch.	
Check that all bearings turn freely. Replace any that are rough or seized.	
Check and make sure that all covers and guards are in place, secured and functioning as designed.	
Check all fasteners and tighten as required. Make sure equipment is working and in good repair.	

6.2 Machine Break-In

Although there are no operational restrictions on the winch when used for the first time, it is recommended that the following mechanical items be checked:

After 1–5 hours of operation:

1. Check all nuts, bolts and other fasteners. Tighten to specified torque.
2. Check condition of winch clutch.
3. Check the condition of the rope. Replace if kinked, frayed or if it has any broken strands.
4. Check for entangled material. Remove all entangled material before resuming work.
5. Check the condition of the clutch rope. Replace if cut, knotted, worn or if it has any broken strands.

6.3 Winch Safety

- **Never stand in line with the path of a rope under tension. Stand at least 10 ft (3 m) to the side to activate the winch. If a rope breaks under tension, it can snap back in an unpredictable direction with great force. The recoil may cause injury or death to a person in its path.**
- **Do not risk a rollover by exceeding a winching angle of $\pm 25^\circ$ from the centerline of the tractor. If unsure of winch angle, reposition tractor or use a snatch block. Whenever possible winch in-line with the tractor.**
- **Do not allow anyone within 20 ft (6 m) of logs when winching. Logs can roll in unpredictable ways.**
- **Choose a flat, solid skidding route for the tractor. Avoid steep slopes.**
- **Check that the winching trail is clear of other trees and obstructions so logs can be winched in easily.**
- **Make sure the winch is lowered and that the tractor parking brake is applied. Operate with the winch blade lowered, on level ground to provide stability.**

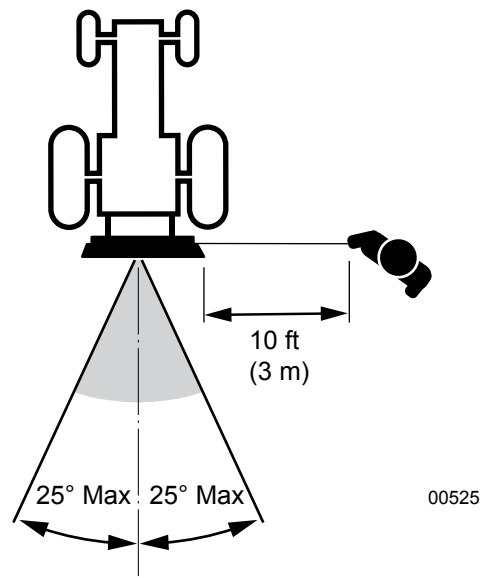
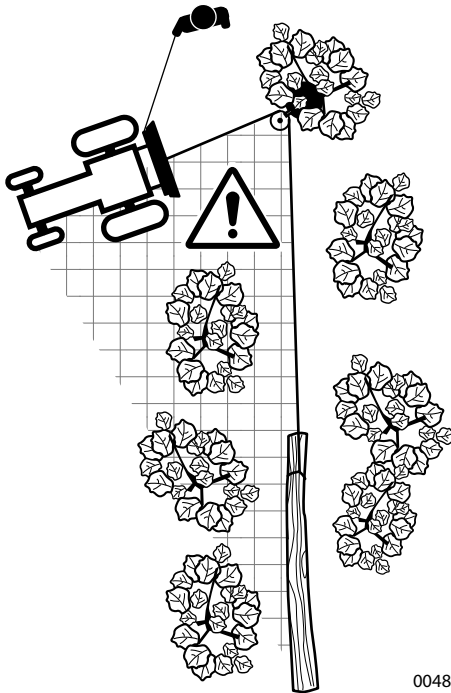

Fig. 40—Safe Winch Angle

IMPORTANT! If the winch is equipped with a synthetic rope, always connect the hook end to a choker chain. Never wrap the synthetic rope around a log or attach the hook end onto the synthetic rope. Incorrect use of the synthetic rope causes damage that is not covered by warranty.

IMPORTANT! Avoid continuous side pulls which can pile up the rope at one end of the drum. This pile up can cause rope damage.

- When using snatch block, be aware of danger zone created between the log, snatch block, and tractor.



00488

Fig. 41 – Using Snatch Block or Self-releasing Pulley

- Do not winch with the tractor sitting sideways on a slope or hillside. Tractor could roll over. Always position the tractor in line with the direction of pull.

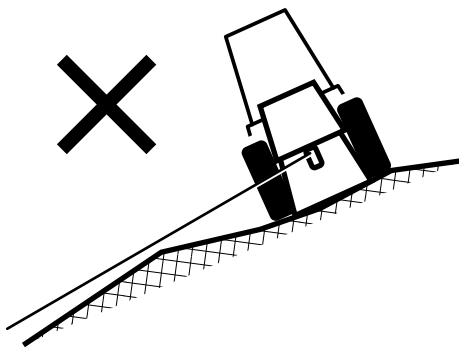

00490

Fig. 42 – Never Winch from the Side on a Slope

- Never winch down a slope. Winching down a slope could cause the log to roll or slide causing crushing injuries. Always winch up-slope when possible.

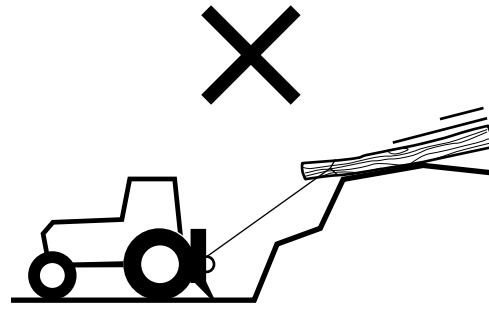

00489

Fig. 43 – Never Winch Down Slope

6.4 Synthetic Winch Rope Safety

! WARNING!

Synthetic rope that fails under tension can snap back with great force causing injury or death. Avoid sudden jerks, quick starts or stops. Start slowly and smoothly. Replace if kinked, badly frayed, has knots, cuts, or broken strands.

W095

IMPORTANT! Heat and exposure to ultra-violet (UV) light break down the fibers of synthetic rope, which weakens the rope and makes it brittle over time. Frequent use in mud, dirt, and sandy conditions can also damage a synthetic rope if it is not thoroughly cleaned and cared for.

Models equipped with synthetic rope from the factory are FX85S, FX85RS, FX110S, FX110RS, FX140S, FX140RS.

The synthetic winch rope included with your Wallenstein FX Series Skidding Winch is a plastic-based rope. Due to its construction, it is lighter than steel cable, but requires more maintenance. It is susceptible to abrasion and becomes brittle over time. Use caution when winching or skidding logs with synthetic rope.

When using synthetic winch rope, avoid the following:

- Winching or skidding through abrasive or sharp surfaces (for example: rocks, concrete, mud, sand).
- Winching with low rope tension.
- Excessive exposure to heat and UV radiation.
- Exposure to harsh chemicals.

Regular cleaning and inspection of the rope's condition is required. For more information, see *Synthetic Winch Rope Maintenance* on page 42.

6.5 Winch Logs

1. Position the machine at the work site.
2. Lower the frame and the blade to the ground.
3. Set the park brake and stop engine.
4. Pull the rope out to the load. Avoid twists in the rope.
5. Attach the choker chain to the log and to the rope end.
6. Start tractor engine and engage PTO. Set throttle to 1/4 to 1/2 range. (Winch speed is based on tractor PTO speed and can operate up to 540 rpm.)
7. Stand to the side of the winch and pull firmly on the clutch rope to retract the rope and load.

IMPORTANT! Keep a steady, firm pull on the clutch rope. Allowing the clutch to slip causes wear on the brake pads.

8. Release the clutch rope when the load is in the desired position. Disconnect from the choker chain.
9. Winch additional logs as required.

IMPORTANT! When pulling cable out of the winch, avoid unwinding it FULLY to the end. Putting tension on it at this point could cause it to pull out of its anchor. Always leave at least five wraps on the drum spool.

CAUTION!

Always wear heavy leather gloves when handling winch rope. Steel rope can develop sharp burrs that can cut hands.

W086

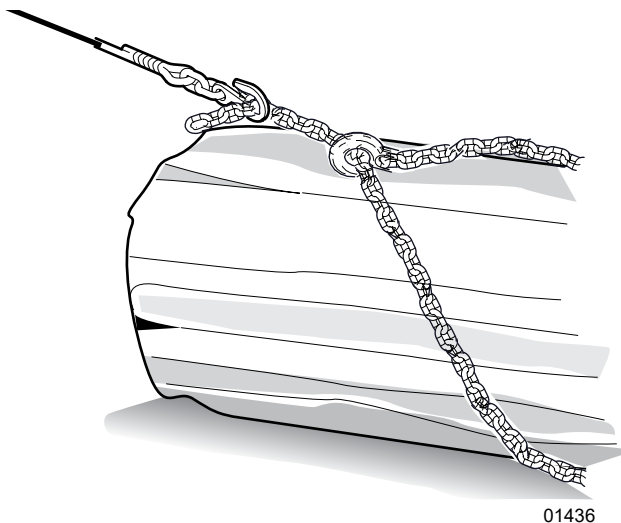

Fig. 44—Choker Chain

IMPORTANT! NEVER wrap the rope around the log or hook the forged end back onto the rope. Damaging the rope in this manner is not covered by warranty. Use a choker chain or synthetic choker around the log instead.

Points to Remember:

- Equip the tractor with weights on the front or a front loader to provide stability. Weight on the front reduces the chance of the tractor tipping back or to the side.
- Set the tractor park brake whenever the winch is being used or the operator is leaving the seat. If operating on steep slopes is necessary, place chocks behind all the tires to prevent the tractor from slipping.
- When operating the winch, always stay at least 10 ft (3 m) to the side of the machine.
- Lower three-point hitch and winch frame to the ground when winching. The weight of the load helps push the blade into the ground, anchoring the winch and the tractor.
- Winching in from the top pulley lifts the end of the log up so it tends to dig into the ground less.
- Always wind rope in under load. Rope does not wind in properly when not under load.
- Several logs can be hooked up and winched in at one time by means of keyhole sliders on the rope.
- Use a log chain or choker to connect to the winch rope. Do not use a rope or strap to prevent breakage from abrasion or snagging. Choker chains have a probe on the end that makes it easier to pass the chain underneath the log.

IMPORTANT! If spooling the rope in with no load, keep a light tension on it to avoid entanglement. Make sure the rope is tightly and evenly layered.

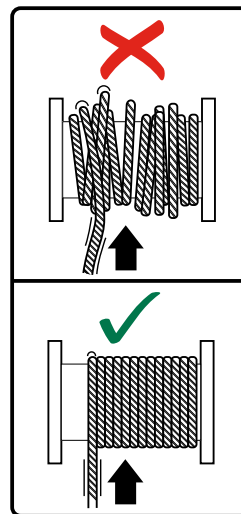

6.6 Skid Logs

WARNING!

Synthetic rope that fails under tension can snap back with great force causing injury or death. Avoid sudden jerks, quick starts or stops. Start slowly and smoothly. Replace if kinked, badly frayed, has knots, cuts, or broken strands.

W095

1. Turn the tractor PTO off and raise winch up above the ground.
2. Lock the winch drum by pulling on the left-hand (green) rope.

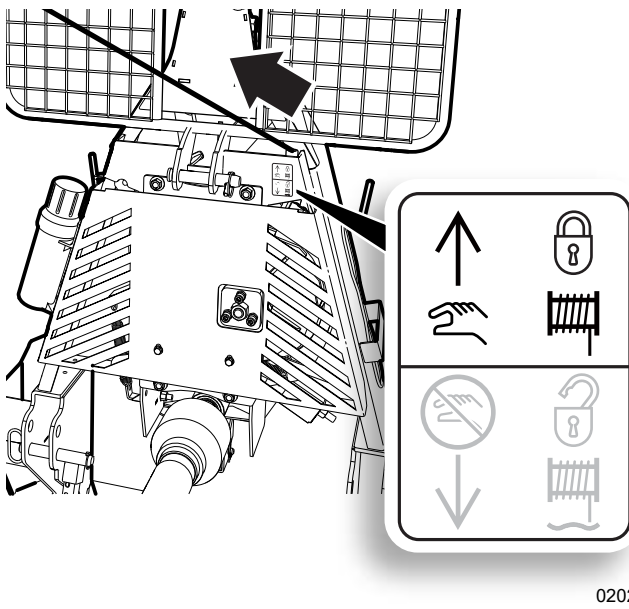

02020

Fig. 45—Winch Drum Lock

3. Drive the tractor forward to pull the load to the desired location.
4. Release the rope to unlock the winch.
5. To relieve tension on the rope to detach the logs, pull slightly on the white (top) rope to release the drum lock.

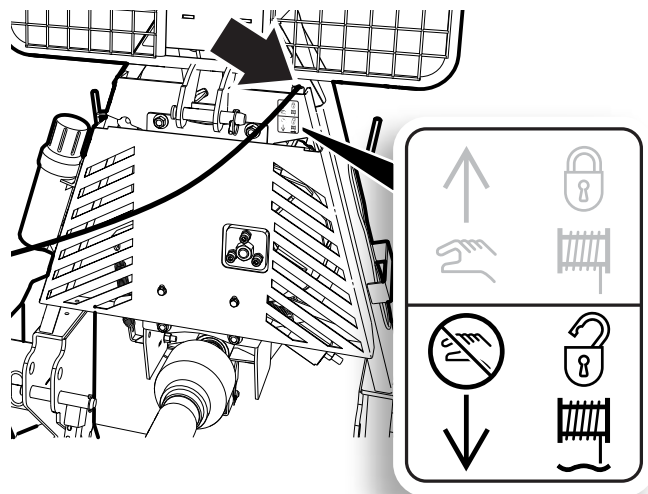

02021

Fig. 46—Unlock Winch Drum

Points to Remember:

- When skidding logs, route the rope through the lower pulley so the tractor is more stable. Skidding from the top of the mast could cause a tip over.
- Raise winch frame up above the ground to clear obstacles when skidding.
- Use a log chain or choker chain to connect to the winch cable. Do not use a rope or strap to prevent breakage from abrasion or snagging.
- Skid logs after they are winched up to the tractor. Be cautious of hills and rough terrain.

Skidding over Rough Ground

- Avoid skidding over rough ground. Unlock the winch to let the rope drum freespool. Leave the log hooked up to the winch.
- Drive the tractor over the rough ground, then stop the tractor and winch the log through.
- Lock the winch drum and continue skidding.

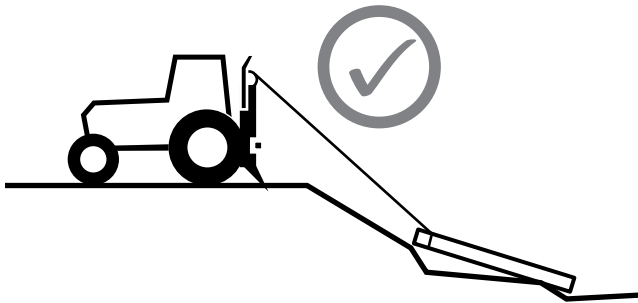
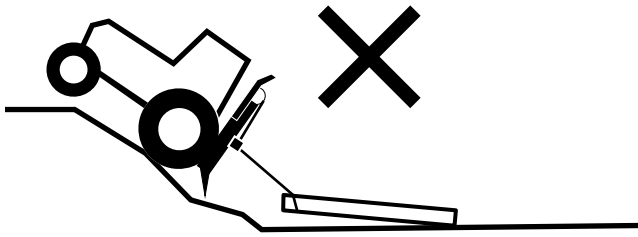

00600

Fig. 47–Winch Log over Rough Ground

Tractor Gets Stuck

- Unlock the winch to let the rope drum freespool.
- Drive the tractor to firm ground, then winch the load back in.
- If the tractor cannot be moved, drop the load and winch the tractor out.

7. Service and Maintenance

CAUTION!

Do not risk injury by working in an unsafe situation. Take steps to make the machine safe to work on before performing any maintenance or service procedure.

Follow steps listed to put the machine in a Safe Condition.

W049

SAFE CONDITION

1. Disengage the PTO.
2. Set the parking brake.
3. Turn tractor engine off. Remove the ignition key. Block the tractor wheels.
4. Make sure all components have stopped moving.
5. Check winch cable is not under tension.

7.1 Maintenance Safety

- Follow good shop practices:
 - Keep service area clean and dry.
 - Be sure electrical outlets and tools are properly grounded.
 - Use adequate light for the job at hand.
- Before servicing or repairing, place the winch in a the **Safe Condition** to work on. See above.
- Never work under equipment unless it is blocked securely.
- When performing any service or maintenance work always wear proper personal protection equipment.
- Use only genuine factory replacement parts to restore the winch to original specifications. Wallenstein is not be responsible for injuries or damages caused by use of unapproved parts or accessories.
- When completing a maintenance or service function, make sure all safety shields and devices are installed before placing machine in service.
- When cleaning parts, do not use gasoline or diesel fuel. Use regular cleanser.
- Always use proper tools in good condition.
- Make sure a procedure is understood before beginning.

7.1.1 Hydraulic System Safety

- Make sure that all the components in the hydraulic system are kept clean and in good condition.
- Make sure all connections are tight, and that lines, hoses and couplings are not damaged before applying pressure to the system.
- Do not use a hand to check for hydraulic oil leaks. Hydraulic fluid escaping under pressure can penetrate the skin causing serious injury. Use a piece of cardboard.



- Wear proper hand and eye protection when searching for a high pressure hydraulic leak.

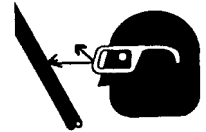

- Seek medical attention immediately if injured by a concentrated high-pressure stream of hydraulic fluid. Serious infection or toxic reaction can develop from hydraulic fluid piercing the skin surface.
- Do not attempt any makeshift repairs to the hydraulic lines, fittings or hoses by using tape, clamps or cements. Doing so can cause sudden failure and create a hazardous and unsafe condition.
- Relieve pressure on the hydraulic system before working it. The hydraulic system operates under extremely high pressure.
- Replace any hydraulic hose immediately that shows signs of swelling, wear, leaks or damage before it bursts.
- Do not bend or strike high-pressure lines, tubes or hoses, or reinstall them in a bent or damaged condition.
- Check to make sure hydraulic hoses are not worn or damaged, and are routed to avoid chafing.
- Never adjust a pressure relief valve or other pressure-limiting device to a higher pressure than specified.

7.2 Maintenance Schedule

Perform maintenance procedures at time shown or hour interval, whichever comes first.

As Required
Remove any entangled material from winch.
Check that all fasteners are tight.
Check the condition of all ropes, chains and cables.
Check clutch adjustment. See page 18.

Every 50 hours or weekly	
Grease PTO shaft	See page 38
Lubricate, check chain drive	See page 39
Check condition of clutch rope.	—

Every 100 hours or Annually	
Clean machine. Remove debris and entangled material.	—
Check chain tension	See page 40
Disassemble PTO shaft to clean and lubricate.	—
Inspect winch rope.	—

7.3 Grease Points

Use an SAE multi-purpose high temperature grease with extreme pressure (EP) performance. Also acceptable is an SAE multipurpose lithium-based grease.

Use a hand-held grease gun for all greasing. Pump one shot of grease slowly into each fitting.

- Wipe grease fitting with a clean cloth before greasing to avoid injecting dirt and grit.
- If fittings do not take grease, remove and clean them thoroughly. Replace grease fittings as necessary.

IMPORTANT! Do not over grease. Pumping more than one shot from a grease gun into the bearings can push the grease out of the seals. Doing that repeatedly can damage the seals. Grease is then not kept in, and dirt and moisture are not kept out.

Location	Grease every 50 hours of operation or weekly
1	Drive shaft, PTO shaft shield and U-joints (2 places)
2	Drive shaft slip joint

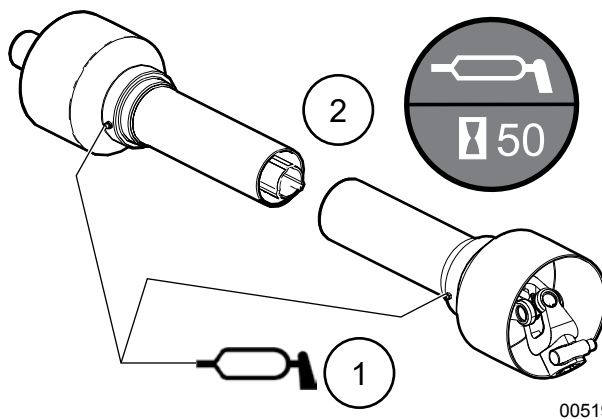
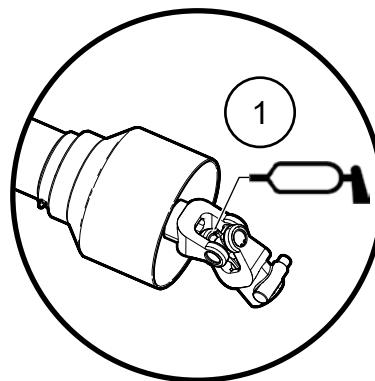
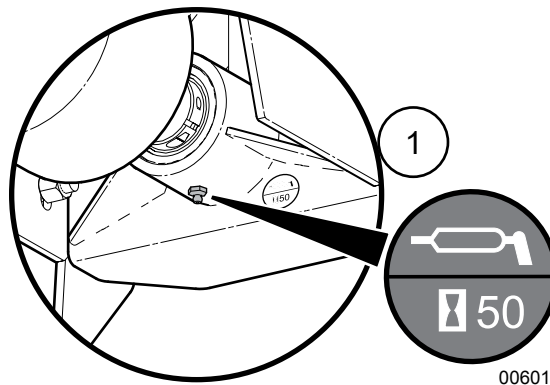

Fig. 48—Grease Points

The PTO shaft is designed to telescope as the 3-point hitch goes through its operational range. A heavy duty plastic tubular guard encloses the driving components.

The PTO shaft should telescope easily and the guard turn freely on the shaft at all times. Annual disassembly, cleaning and lubrication is recommended to make sure that all components function as intended.

Make sure that the universal joints are lubricated, inspect and lubricate every 50 hours.

The PTO shaft has a shear pin at the input yoke to prevent overloading the drive system. The winch is designed to perform well without the shear pin failing. However, if the pin does fail, generally it is because the winch was overloaded.

7.4 Drive Chain Lubrication

Lubricate the drive chain every 50 hours of operation. A chain operating in a dry condition can wear excessively leading to premature failure.

- Remove the lower protective shield on the front side of the winch.
- Spray or brush oil onto the lower drive chain. A good quality penetrating oil such as WD40® works well to reach the pin and bushing joints.

IMPORTANT! Avoid getting oil on the clutch brake pads. Lubricant on the pads can cause the clutch to slip.

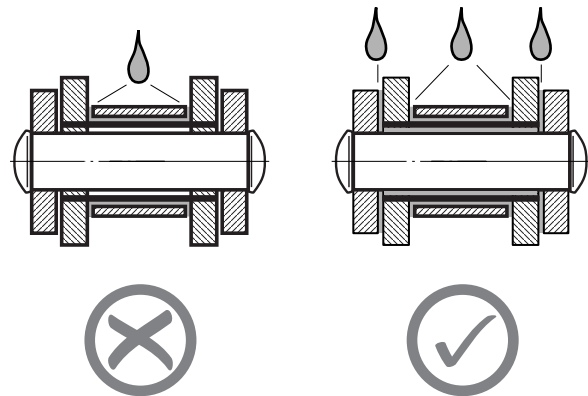
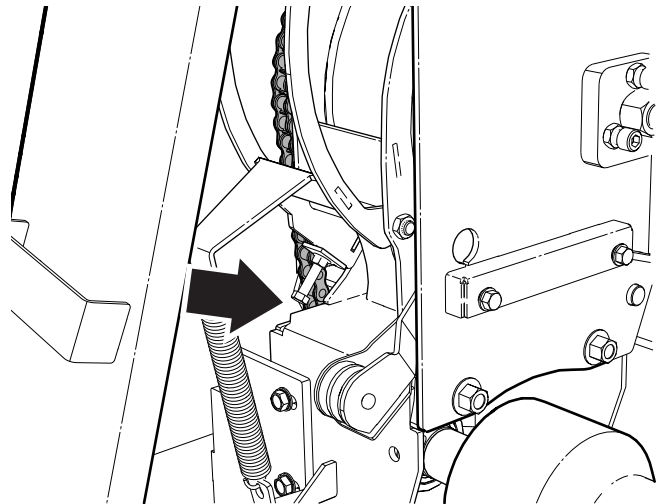

00602

Fig. 49—Proper Roller Chain Lubrication

IMPORTANT! Make sure the lubricant reaches the joints (pins, bushings), which are subject to wear.

7.5 Drive Chain Tension

The winch is designed with a roller chain to transmit the power between the PTO input and the clutch / winch. The chain tension is automatically set through a spring-loaded sliding tensioner.

The chain tensioning system is designed with an internal compression spring to set maximum chain tension during operation. No adjustment is required.

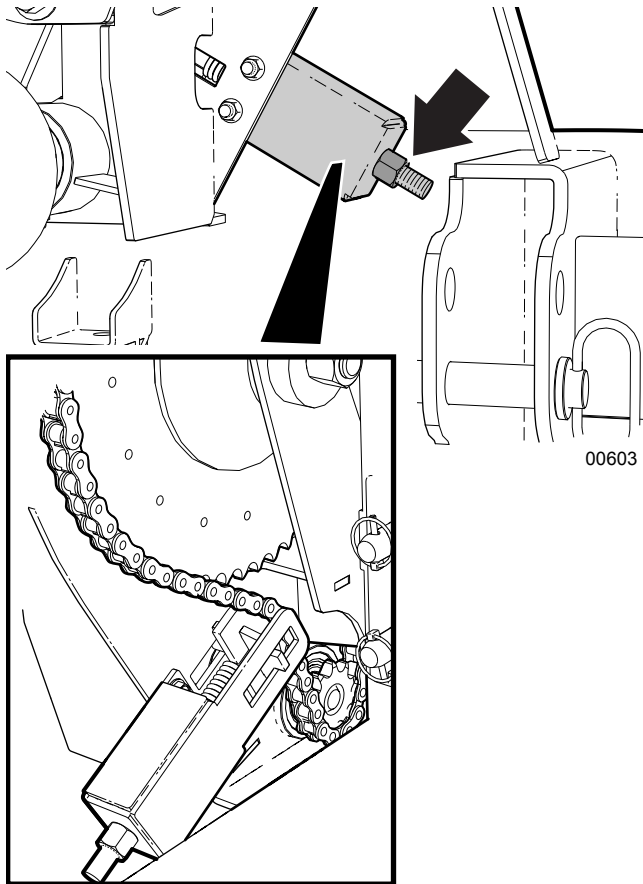

Fig. 50—Chain Tensioner

7.5.1 Drive Chain Replacement

If replacing the roller chain, follow this procedure to release tension on the chain:

1. Turn in (tighten) the adjusting nut on tension bolt until chain tension is released (minimum chain tension).
2. Remove the old chain and install the new chain.
3. To set the chain to maximum tension, turn out the adjusting nut on tension bolt within 1/4" (6 mm) from end of tension bolt.

7.6 Clutch Adjustment

Adjust the clutch using the following method if it begins to slip or goes out of adjustment.

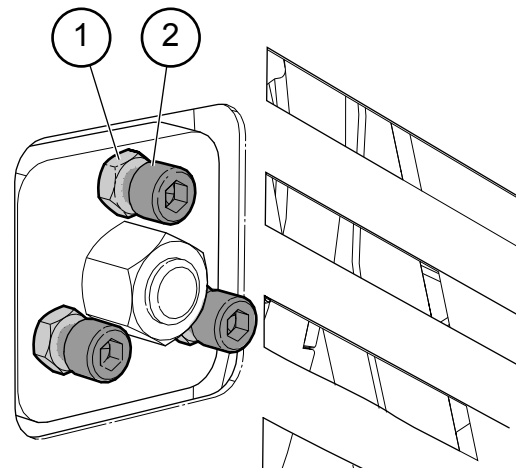

Fig. 51—Clutch Adjustment

1. Jam Nut
2. Socket Head Capscrew

Procedure

1. Loosen the three jam nuts on the front side of the winch.
2. Turn socket head capscrews inward by hand until they just contact the pressure plates.
3. Tighten bolts equally until the desired amount of free play is felt on clutch lever. Pull on rope to feel free play in clutch and adjust as required.
4. Tighten jam nuts.
5. Check clutch setting before resuming work. Start PTO and check for drag on the clutch.

Drag can cause the winch rope to inch in without the rope being pulled. If the rope is inching in with the clutch disengaged, go through the above steps again to readjust.

7.7 Drum Brake Adjustment

7.7.1 Winch Drum Brake Operation

The winch brake stops the drum from turning when there is no tension on the rope and the drum lock is not engaged. The brake must be set to hold the drum from freewheeling when the rope is not being pulled out to avoid tangling.

As the rope is spooled off the drum, it is routed over the top of the brake assembly arm. The force of spooling the rope off the drum, moves the arm to release the brake. When the rope is no longer being spooled on, the spring pulls the arm back and engages the brake. The brake must be set to stop the drum from freewheeling when the rope is not being pulled out to avoid tangling.

Remove lower protective shield from the front side of the winch to access brake adjustment.

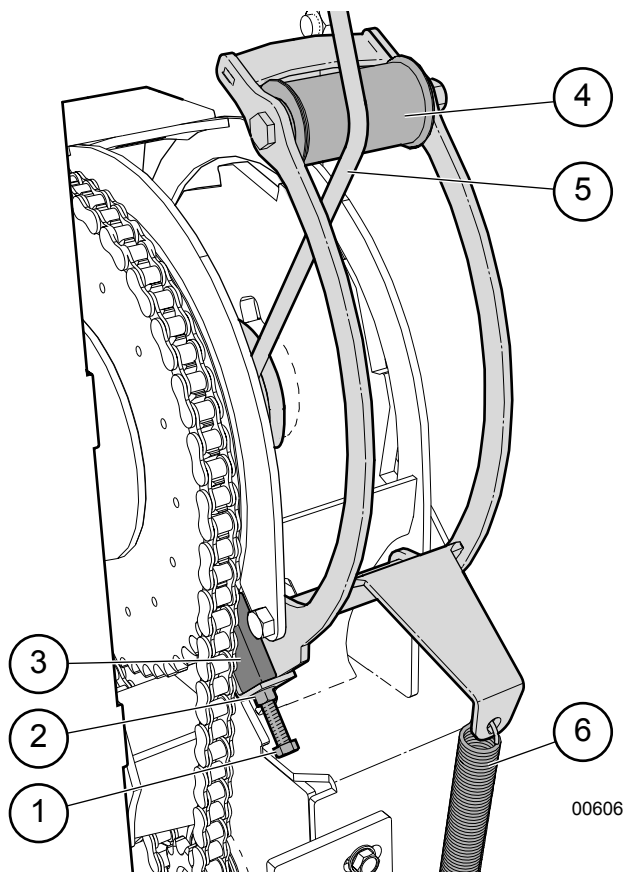

Fig. 52—Winch Brake

1. Adjuster Bolt
2. Jam Nut
3. Drum Brake Block
4. Brake Arm Cable Roller
5. Cable
6. Spring

7.7.2 Procedure

1. Loosen jam nut (2) on adjustment bolt.
2. Tighten the adjustment bolt (1) until the brake block (3) just contacts the drum.
3. Tighten jam nut.

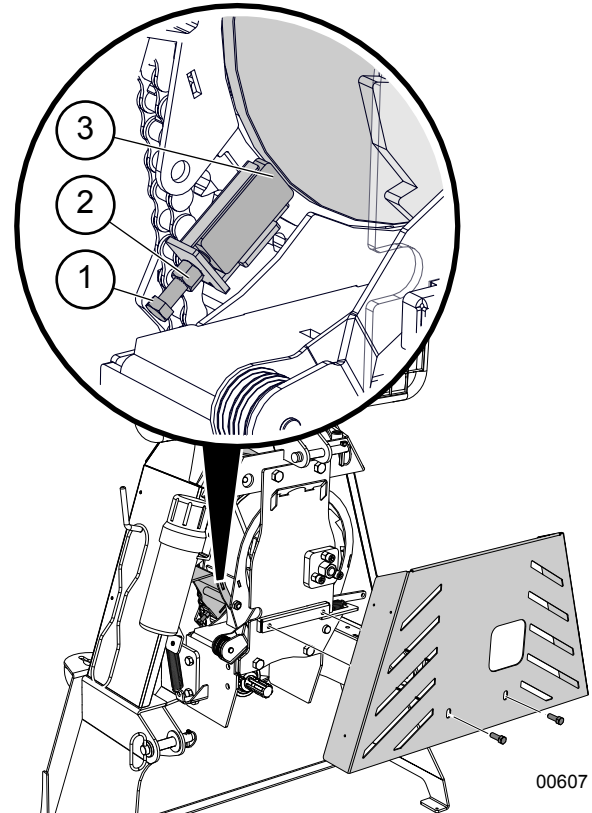

Fig. 53—Winch brake Adjust

1. Adjuster Bolt
2. Jam Nut
3. Drum Brake Block

7.8 Replace the Synthetic Winch Rope or Steel Winch Cable

CAUTION!

Replace a synthetic winch rope with the correct type of synthetic rope. Use of an incorrect type of synthetic rope can result in the rope breaking and causing personal injury. For information about the correct replacement synthetic winch rope, see the Wallenstein Equipment Parts Manual.

W094

1. Feed the winch rope or cable through the eye of the cable guide (2) and over the pulley into the drum. Before feeding a synthetic winch rope, wrap the end of the rope with electrical tape to hold the ends of the rope together.
2. Route the winch rope or cable under the brake arm cable roller (3) on the drum band coiler.
3. Insert the winch rope or cable through the hole in the drum into the anchor (5).

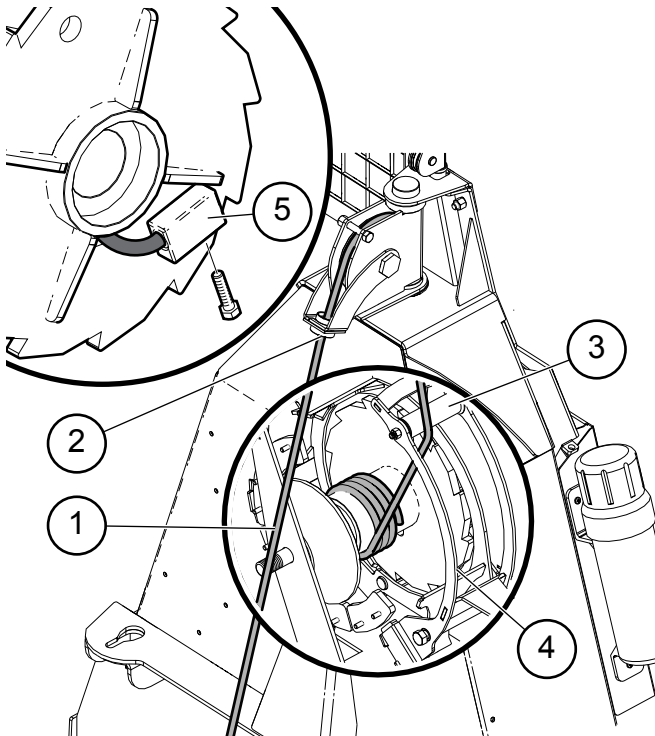

Fig. 54—Installing the Synthetic Winch Rope or Steel Winch Cable

1. Winch Rope or Cable
2. Cable Guide
3. Brake Arm Cable Roller
4. Cable Drum
5. Drum Cable Anchor

7.9 Synthetic Winch Rope Maintenance

IMPORTANT! Heat and exposure to ultra-violet (UV) light break down the fibers of synthetic rope, which weakens the rope and makes it brittle over time. Frequent use in mud, dirt, and sandy conditions can also damage a synthetic rope if it is not thoroughly cleaned and cared for.

7.9.1 Inspect the Synthetic Winch Rope

Check the entire synthetic winch rope for wear and re-spool it neatly (under tension) after every use. Check the synthetic winch rope for any cut strands, fraying parts, abrasion, or heat damage from the winch. After some use, all winch ropes get a little fuzzy from abrasion. This is normal. However, **if an entire strand is cut, the synthetic winch rope must be replaced or repaired.** All strands must be intact for the synthetic winch rope to work properly and maintain its strength.

7.9.2 Clean the Synthetic Winch Rope

When dirt and grit become lodged between the strands of the synthetic winch rope, they cause abrasion to the fibers when the winch rope operates under load. Over time, this can cause the synthetic winch rope to lose integrity and strength.

1. Unspool and remove the entire rope from the winch.
2. Lay the rope on a clean surface.
3. Use a water hose to rinse the rope.
4. To remove dirt and grit from the strands:
 - a. Fill a bucket with water and mild soap.
 - b. Place the rope in the bucket.
 - c. Lay a clean towel beside the bucket to place the clean portion of the rope on.
 - d. Starting at one end of the rope, push the rope strands together to open them up and rinse between them.
 - e. Work your way through the entire rope until the clean rope is laying on the towel.
 - f. Inspect the winch spool and fairlead for sharp or rough surfaces that could damage the rope. If required, remove or repair sharp or rough surfaces.
5. Dry the rope.
6. Wind the rope neatly (under tension) onto the winch.

7.10 Brake and Clutch Rope Routing

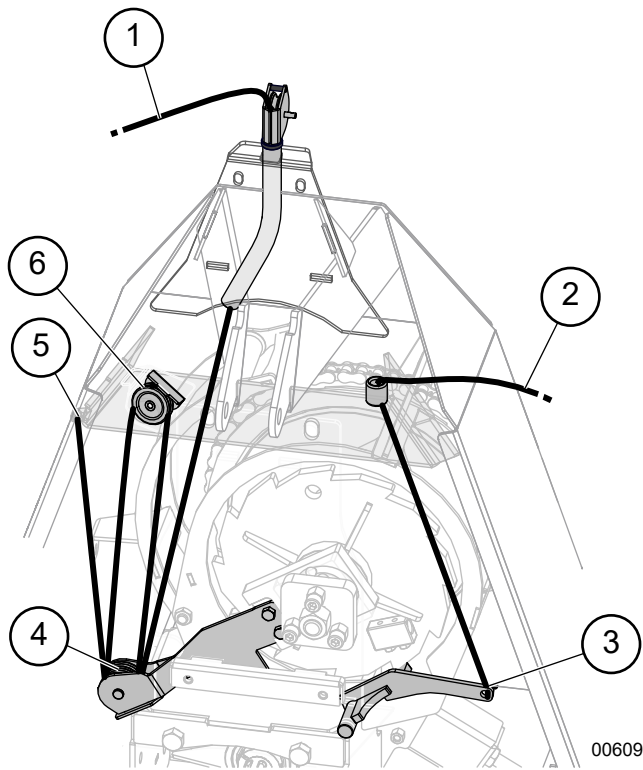

Fig. 55—Rope Routing

1. Clutch Control Rope (white)
2. Brake Control Rope (green)
3. Tie-off Point
4. Double Pulley
5. Tie-off Point
6. Single Pulley.

7.11 Storage

After the season's use or when the machine is not going to be used for a period of time, place the winch in storage.

Completely inspect all major systems. Replace or repair any worn or damaged components to prevent any unnecessary down time at next use.

1. Park the winch away from human activity in a dry, level area.
2. Lower the winch to the ground. Make sure support legs are lowered and locked in position. If the ground is soft, place a board or plate under the leg.



FX85 has a wide base and does not use a leg stand.

3. Detach winch from the tractor. Keep the PTO shaft out of the dirt by resting it on wood blocking.
4. Wash the machine to remove all dirt, mud, and debris. Inspect all rotating parts and remove any entangled material.
5. Check the condition of chain and sprockets. Replace or adjust as required.
6. If the winch cannot be stored inside, cover with a waterproof tarp.

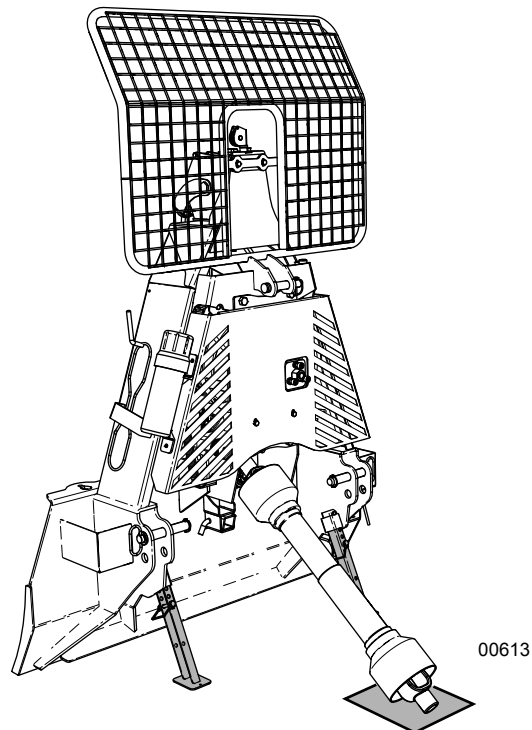
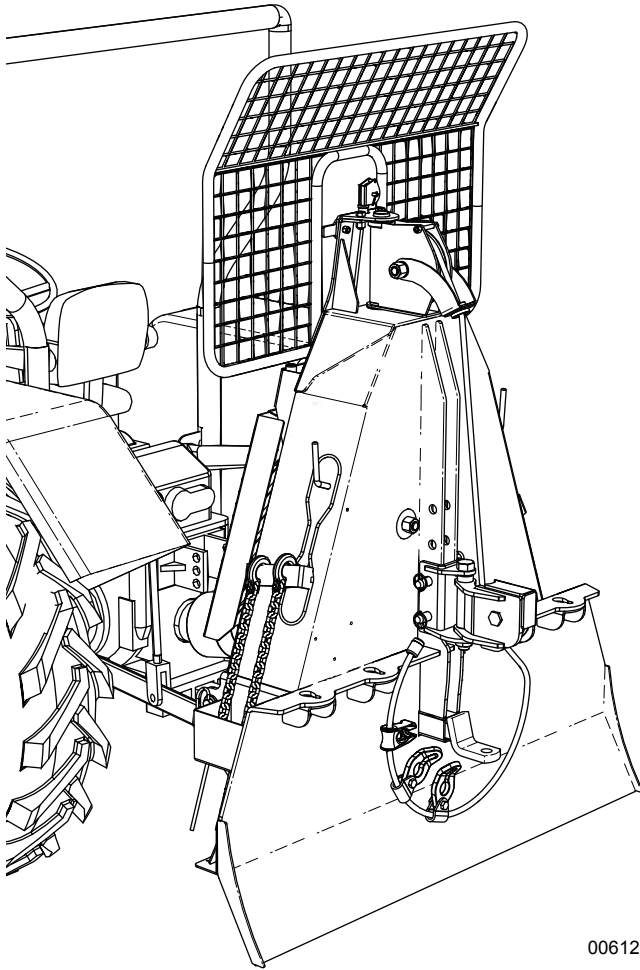

Fig. 56—Storage Position

7.12 Transporting



00612

Fig. 57 – Winch Attached

- Comply with local laws governing safety and transporting of machinery on public roads.
- Do not exceed a safe travel speed. Slow down for rough terrain.
- Be sure the winch is hitched properly to the tractor and a retainer is used through the mounting pins.
- Never allow riders on the machine.
- Be a safe and courteous driver. Always yield to oncoming traffic in all situations, including narrow bridges, intersections, and so on.
- Watch for traffic when near or crossing roadways.
- Do not drink and drive.

8. Troubleshooting

If a problem is encountered that is difficult to solve, even after having read through this troubleshooting section, contact your local dealer, distributor or Wallenstein Equipment.

Identify machine serial number. See *page 5*.

Problem	Cause	Solution	
Cable does not retract.	Cable jammed.	Disengage winch or release brake, pull cable out and rewind cable onto the spool. Check winch brake.	
	Winch clutch disengaged.	Engage clutch.	
	PTO not operating.	Turn tractor PTO drive on.	
	Clutch brake pads worn out.	Replace pads.	
	Clutch out of adjustment.	Adjust clutch.	
	Broken PTO shaft shear pin.	Replace pin and reduce size of load.	
	Remote control.		Check transmitter power is on.
			Check that receiver power is on.
			Check wiring for power into the receiver.
			Check transmitter battery LED status/error display (flashing).
		Check electrical circuit ground.	
	Check hydraulic system function.		
Cable does not pull out.	Winch drum lock engaged.	Disengage winch lock.	
	Cable jammed.	Disengage winch or release brake and pull cable out. Rewind cable onto the spool. Check winch brake.	
Slow cable retraction.	PTO shaft speed too slow.	Increase PTO speed (maximum 540 rpm)	
	Clutch slipping.		Pull harder on clutch rope.
			Adjust Clutch.
			Clutch brake pads worn. Replace.
			Reduce load.
	Grease or oil has got on clutch brake pads, probably resulting from improper chain lubrication. Clean or replace clutch brake pads.		
Winch does not lock.	Clutch not engaged.	Pull harder on clutch rope.	
	Clutch brake pads worn out.	Inspect or replace brake pads.	
	Drum lock broken	Inspect and repair or replace lock mechanism.	
Drive chain comes off.	Drive chain too loose.	Check the alignment of the chain and for possible damage. Adjust chain tension. Replace if necessary	
Cable twists / jams and does not wind in correctly.	Winch brake not working properly.	Clean brake block (greasy).	
		Adjust brake block	
		Replace brake block (worn out).	
		Repair damaged brake parts.	
Cable pulls out when clutch engaged.	Clutch out of adjustment.	Adjust clutch to prevent cable creep.	

Problem	Cause	Solution
Winch jerks and shakes while in operation.	Drive chain loose.	Check chain tensioner and adjust.
	Drive sprocket misaligned. PTO shaft too long.	Check that PTO shaft is the correct length.
Front end of tractor comes off ground when winching.	Tractor too light in front.	Add front end weights.
Tractor slides backwards when winching	Parking brake not applied.	Apply parking brake.
	Winch blade not fully lowered enough to anchor firmly in the ground.	Lower the winch all way to the ground.

9. Specifications

9.1 Machine Specifications¹

Specification	FX85 / FX85R	FX85S / FX85RS	FX110 / FX110R	FX110S / FX110RS	FX140 / FX140R	FX140S / FX140RS
Weight	470 lb 213 kg		796 lb 361 kg		898 lb 407 kg	
Machine Dimensions L x W x H	27" x 40" x 76" 68 x 101 x 193 cm		28" x 50-1/2" x 79" 71 x 128 x 200 cm		28" x 58-1/2" x 80" 71 x 149 x 203 cm	
Pulling Capacity	8,500 lb 3 855 kg		11,000 lb 4 989 kg		14,000 lb 6 350 kg	
Horsepower Range	30–60 hp 13–45 kW		45–100 hp 34–75 kW		60–140 hp 45–104 kW	
PTO Input Speed (Maximum)	540 rpm					
Winch Type	Mechanical, Dry Disk Clutch – Adjustable					
Winch Line Speed	96–238 ft/min 29–72 m/min		98–253 ft/min 30–77 m/min		98–246 ft/min 30–75 m/min	
Steel Winch Cable Length	165 ft 50 m	N/A ²	165 ft 50 m	N/A	165 ft 50 m	N/A
Steel Winch Cable Maximum Length Capacity	239 ft 73 m	N/A	207 ft 63 m	N/A	165 ft 50 m	N/A
Steel Winch Cable Diameter	7/16" 11 mm	N/A	1/2" 12.7 mm	N/A	1/2" 12.7 mm	N/A
Synthetic Winch Rope Length	N/A	200 ft 61 m	N/A	200 ft 61 m	N/A	200 ft 61 m
Synthetic Winch Rope Diameter	N/A	7/16" 11 mm	N/A	1/2" 12.7 mm	N/A	1/2" 12.7 mm
Maximum Input Torque	265 lbf•ft 360 N•m		351 lbf•ft 476 N•m		450 lbf•ft 610 N•m	
Maximum Bare Drum Pull	8,553 lb 3 879 kg		11,130 lb 5 048 kg		14,053 lb 6 374 kg	
Maximum Full Drum Pull	2,992 lb 1 357 kg		3,673 lb 1 666 kg		4,733 lb 2 146 kg	
Hydraulic Flow Required for Remote Control	(This only applies to R and RS models) 1–2 gpm 3.8–7.6 Lpm					
Mounting System Category	CAT I		CAT I and II		CAT II	
Available Accessories	Self-releasing Directional Pulley Logging Tongs Choker Chain Chainsaw Holder					

¹ Specifications subject to change without notice.

² N/A indicates that a specification is not applicable.

9.2 Common Bolt Torque Values

Checking Bolt Torque

The tables shown give correct torque values for various bolts and capscrews. Tighten all bolts to the torque values specified in the table, unless indicated otherwise. Check tightness of bolts periodically.

IMPORTANT! If replacing hardware, use fasteners of the same grade.

IMPORTANT! Torque figures indicated in the table are for non-greased or non-oiled threads. Do not grease or oil threads unless indicated otherwise. When using a thread locker, increase torque values by 5%.

 **NOTE:** Bolt grades are identified by their head markings.

Imperial Bolt Torque Specifications						
Bolt Diameter	Torque Value					
	SAE Gr. 2		SAE Gr. 5		SAE Gr. 8	
	lbf•ft	N•m	lbf•ft	N•m	lbf•ft	N•m
1/4"	6	8	9	12	12	17
5/16"	10	13	19	25	27	36
3/8"	20	27	33	45	45	63
7/16"	30	41	53	72	75	100
1/2"	45	61	80	110	115	155
9/16"	60	95	115	155	165	220
5/8"	95	128	160	215	220	305
3/4"	165	225	290	390	400	540
7/8"	170	230	420	570	650	880
1"	225	345	630	850	970	1320



Metric Bolt Torque Specifications				
Bolt Diameter	Torque Value			
	Gr. 8.8		Gr. 10.9	
	lbf•ft	N•m	lbf•ft	N•m
M3	0.4	0.5	1.3	1.8
M4	2.2	3	3.3	4.5
M6	7	10	11	15
M8	18	25	26	35
M10	37	50	52	70
M12	66	90	92	125
M14	83	112	116	158
M16	166	225	229	310
M20	321	435	450	610
M30	1,103	1 495	1,550	2 100



9.3 Hydraulic Fitting Torque Values

Tightening Flare Type Tube Fittings

1. Check flare and flare seat for defects that might cause leakage.
2. Align tube with fitting before tightening.
3. Hand-tighten swivel nut until snug.
4. To prevent twisting the tube, use two wrenches. Place one wrench on the connector body and tighten the swivel nut with the second. Torque to values shown.

If a torque wrench is not available, use the FFFT (Flats From Finger Tight) method.

Hydraulic Fitting Torque					
Tube Size OD	Hex Size Across Flats	Torque value		Flats From Finger Tight	
		Inches	Inches	lbf•ft	N•m
3/16	7/16	6	8	2	1/6
1/4	9/16	11–12	15–17	2	1/6
5/16	5/8	14–16	19–22	2	1/6
3/8	11/16	20–22	27–30	1-1/4	1/6
1/2	7/8	44–48	59–65	1	1/6
5/8	1	50–58	68–79	1	1/6
3/4	1-1/4	79–88	107–119	1	1/8
1	1-5/8	117–125	158–170	1	1/8

Values shown are for non-lubricated connections.

10. Accessories

Contact your dealer or distributor for pricing and availability.

Choker Chains



00549

Fig. 59 – Steel Choker Chain

Self-releasing Directional Pulley

When obstacles prevent direct winching, or to prevent damage to other trees, the Wallenstein self-releasing directional pulley should be used. The pulley releases the rope when the keyhole slider reaches it.

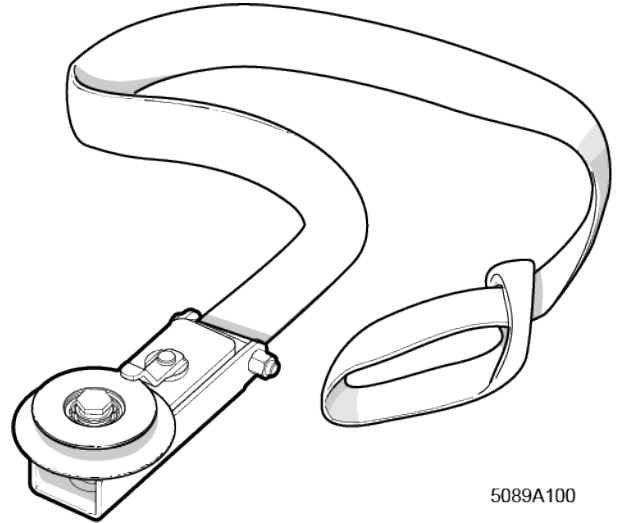

5089A100

Fig. 61 – Self-releasing Directional Pulley

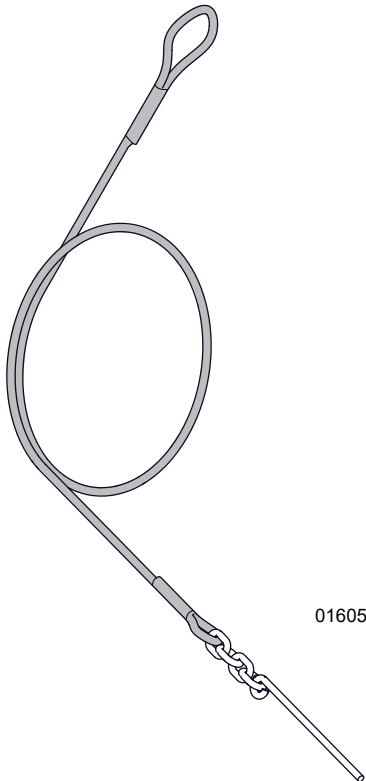

01605

Fig. 60 – Synthetic Choker

Chain Saw Holder

The chain saw holder bolts to the side of the winch.

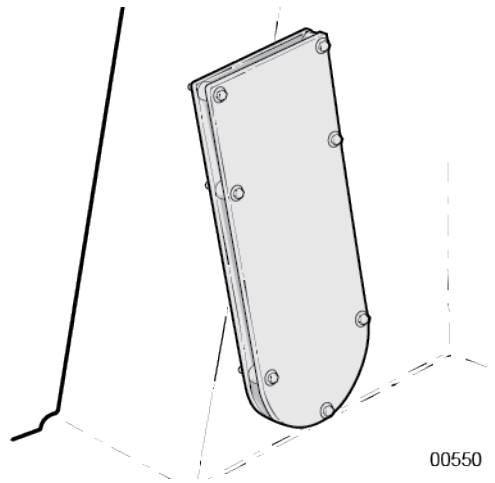

00550

Fig. 62 – Chain Saw Holder

11. Product Warranty



LIMITED WARRANTY

Wallenstein products are warranted to be free of defects in materials and workmanship under normal use and service, for a period of

Five Years for Consumer Use
Two Years for Commercial/Rental Use

from the date of purchase, when operated and maintained in accordance with the operating and maintenance instructions supplied with the unit. Warranty is limited to the repair of the product and/or replacement of parts.

This warranty is extended only to the original purchaser and is not transferable.

Repairs must be done by an authorized dealer. Products will be returned to the dealer at the customer's expense. Include the original purchase receipt with any claim.

This warranty does not cover the following:

- 1) Normal maintenance or adjustments
- 2) Normal replacement of wearable and service parts
- 3) Consequential damage, indirect damage, or loss of profits
- 4) Damages resulting from:
 - Misuse, negligence, accident, theft or fire
 - Use of improper or insufficient fuel, fluids or lubricants
 - Use of parts or aftermarket accessories other than genuine Wallenstein parts
 - Modifications, alteration, tampering or improper repair performed by parties other than an authorized dealer
 - Any device or accessories installed by parties other than an authorized dealer
- 5) Engines. Engines are covered by the manufacturer of the engine for the warranty period they specify. For the details of your engine warranty, see your engine owner's manual. Information about engine warranty and service is also available in the FAQ section at www.wallensteinequipment.com

12. Index

A		I	
Accessories	50	Informative Labels	6
Attaching Winch to Tractor	18, 31	Installing PTO Shaft	23
Remote Winch Control	19	I/O Button	28
B		K	
Bolt torque	48	Keyhole Sliders	25
Brake and Clutch Rope Routing	43	Keyhole Slots	25
Break-in	32	L	
C		Lower Snatch Block	26
Cable Install	42	M	
Checking Bolt Torque	48	Machine Break-In	32
Choker Chains	26	Machine Specifications	47
Clutch Adjustment	40	Maintenance	
Controls		Synthetic Winch Rope	
Choker Chains	26	Clean the Synthetic Winch Rope	52
Forged Cable End	24	Inspect the Synthetic Winch Rope	42
Keyhole Sliders	25	Maintenance Schedule	38
Keyhole Slots	25	100 hours or Annually	38
Remote Winch Control	27	As required	38
Safety Screen	27	Every 50 hours or weekly	38
Snatch Block	26	Every 100 hours or Annually	38
Synthetic Chokers	26	Models equipped with synthetic rope	33
Trailer Hitch	27	O	
Winch Clutch	24	Operating Instructions	31
Winch Drum Lock	24	Winching Safety	32
D		Operating Safety	8
Delivery Inspection Report	4	Operation	
Determine Proper PTO Shaft Length	20	Pre-Operation Checklist	31
Drive Chain Lubrication	39	Skidding	35
Drive Chain Tension	40	Skidding over Rough Ground	35
Drum Brake Adjustment	41	Winching Logs	34
E		Operator Orientation	16
Equipment Safety Guidelines	9	P	
F		Personal Protective Equipment (PPE)	8
Familiarization	16	Pre-start Checklist	31
Attaching Winch to Tractor	31	Product Labels	6
Equipment Condition	16	R	
Job Site Familiarization	16	Remote Control Operation	29
Machine Break-In	32	Remote Control Receiver	29
Operator Orientation	16	Remote Winch Control	27
Pre-Operation Checklist	31	Manual Override	29
To the New Operator	16	Synchronize Transmitter and Receiver	30
Training	16	Replacing Damaged Safety Signs	15
Forged Cable End	24	Rope Replacement	42
G		S	
Grease Points	38	Safe Condition	8, 37
H		Safety	7
Hand-held Transmitter	28	Equipment Safety Guidelines	9
Hearing loss	9	Hydraulic System Safety	37
Hydraulic Fitting Torque	49	Maintenance Safety	37
Hydraulic System Safety	37	Operating Safety	8

Personal Protective Equipment (PPE)	8
Preparation	9
Safety Alert Symbol	7
Safety Training	9
Signal Words	7
Synthetic Winch Rope	33
Safety Alert Symbol	7
Safety Screen	27
Safety Sign Explanations	12
Safety Signs	12
Safety Training	9
Serial number	5
Service and Maintenance	37
Brake and Clutch Rope Routing	43
Clutch Adjustment	40
Drive Chain Lubrication	39
Drive Chain Tension	40
Drum Brake Adjustment	41
Grease Points	38
Maintenance Safety	37
Maintenance Schedule	38
Rope Replacement	42
Sign-off form	11
Sizing PTO Shaft	20
Skidding	35
Skidding over Rough Ground	35
Specifications	47
FX85 / FX85R / FX85S / FX85RS	47
FX110 / FX110R / FX110S / FX110RS	47
FX140 / FX140R / FX140S / FX140RS	47
Hydraulic Fitting Torque	49
Storage	43
Synchronize Transmitter and Receiver	30
Synthetic Chokers	26
Synthetic Rope keyhole Sliders	25
Synthetic Winch Rope	
Maintenance	
Clean the Synthetic Winch Rope	42
Inspect the Synthetic Winch Rope	42
Safety	33

T

Tractor Gets Stuck	36
Trailer Hitch	27
Transporting	44
Troubleshooting Guide	45
Types of Decals on the Machine	6

W

Warranty	51
Winch Brake Operation	41
Winch Clutch	24
Winch Drum Lock	24
Winching Logs	34
Winch Safety	32



WallensteinEquipment.com

