



***ASSEMBLING, USE
AND MAINTENANCE
SPARE PARTS LIST***

**RP/4 - RP/5 - RP/6
RP/8 - RP/10 - RP/12**

CAUTION FOR USE

It could be dangerous for people who are not familiar with this type of machine to use the rake, particularly when kids are there during the assembly or operation on field. We therefore recommend the use of the rake only to those people who are very familiar with the machine and the safety precautions.

ASSEMBLY SOLUTIONS

rakes are easily convertible into different sizes, as almost all parts are standard and interchangeable on all sizes (wheel arms, wheels - etc.). With a special frame it is possible to attach together two RP/4-RP/5-RP/6 rakes - R.H. and L.H. - and convert them into a V-rake.

Here are the advantages

- 1) Having a R.H. RP/4 rake or a R.H. RP/5 rake or a R.H. RP/6 rake you can convert them into a L.H. RP/4 or L.H. RP/5 or L.H. RP/6 rake by replacing all wheel arms marked RIGHT with those marked LEFT.
- 2) Having a R.H. RP/4 rake you can convert it into a RP/8 V-rake by attaching a L.H. RP/4 rake and the relevant frame. To get one RP/10 V-rake from two RP/5 rake the procedure is still the same. To get one RP/12 V-rake from two RP/6 rake the procedure is still the same.
- 3) You could also use your V-rake as two single ones, L.H. or R.H. rake, according to your requirements.

SPECIFICATIONS

MODELS	RP/4	RP/5	RP/6	RP/8	RP/10	RP/12
Weight	180Kg/396lbs	200Kg/440lbs	250Kg/551lbs	460Kg/1013lbs	520Kg/1146lbs	620Kg/1366lbs
Number of wheels	4	5	6	8	10	12
Number of tines on each wheel	40	40	40	40	40	40
Wheel diam.	1,4 m / 55"	1,4 m / 55"	1,4 m / 55"	1,4 m / 55"	1,4 m / 55"	1,4 m / 55"
Raking working width	2,6 m / 8' 6"	3,5 m / 11' 6"	4,1 m / 13' 6"	5,5 / 18' 1"	7,5 m / 24' 7"	8,7 m / 28' 6"
Turning and spreading working width	2,9 m / 9' 6"	3,9 m / 12' 10"	4,4 m / 14' 5"	6,1 / 20"	8,7 m / 28' 7"	10 m / 32' 10"
Transport width	2,2 m / 7' 3"	2,3 m 7' 6"	2,3 m / 7' 6"	3,6 m 11' 10"	4,7 m / 15' 5"	4,7 m / 15' 5"
Working speed	22 kmh/14mph	22 kmh/14mph	22 kmh/14mph	22 kmh/14mph	22 kmh/14mph	22 kmh/14mph
KW/HP required min.	22 Kw / 30 HP	22 Kw / 30 HP	22 Kw / 30 HP	30 Kw / 40 HP	30 Kw / 40 HP	30 Kw / 40 HP

RP/4-RP/5 AND RP/6 RAKE ASSEMBLY INSTRUCTIONS

To save room in the container we supply the rakes partly knocked down. Here below please find assembly instructions. For part numbers please refer to the enclosed parts breakdown.

ASSEMBLING

- a) Position the parking stand (15) in its housing and lock it with the pin (13). Next, lay the primary structure (supplied assembled) on the ground with the swinging pipe (31) upwards (pict. 1).

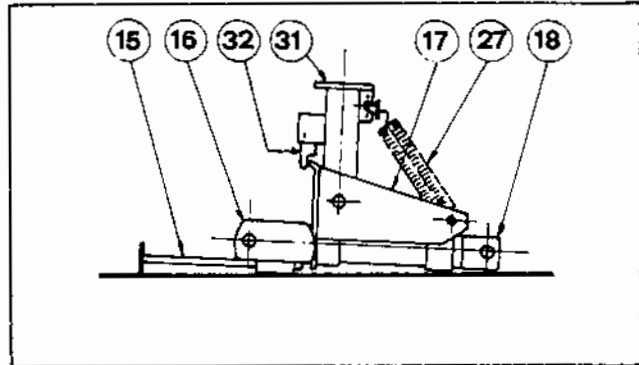

Pict. 1

- b) Slide the main pipe (37) into the swinging pipe (31) and retain with the supplied lever (33) and pin (36), so that it is on axle with the three point hitch (pict. 2).

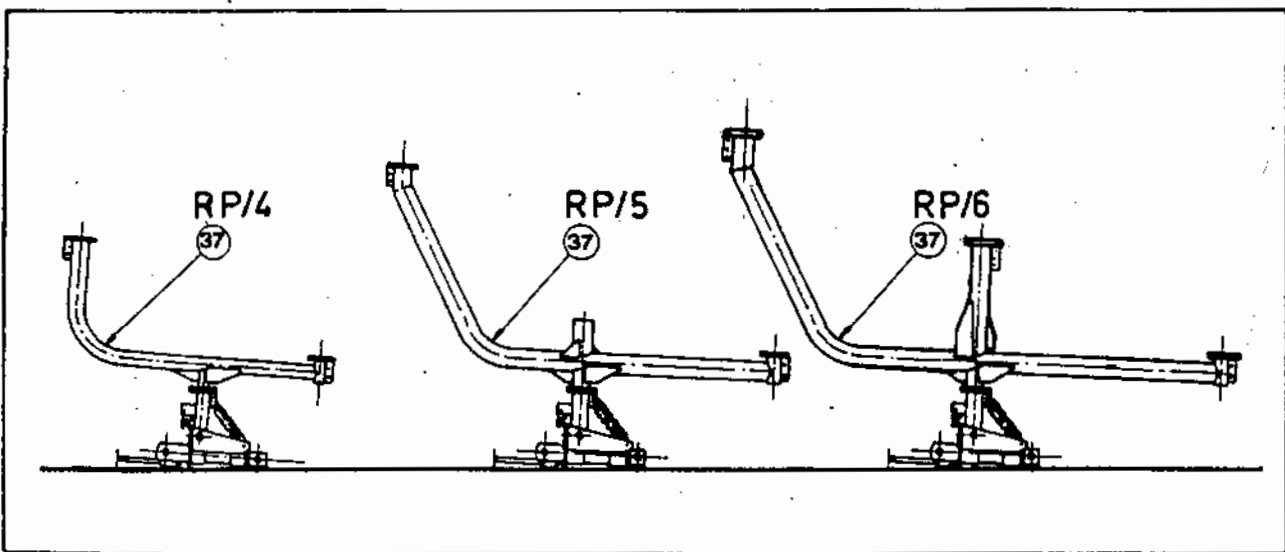

Pict. 2

- c) Attach the wheel arms (38) and lock them to the main pipe (37) with pins (36), so that they are on axle with the main pipe (37). For the RP/5 rake, attach also the central arm (55) to the main pipe (37) and retain with bolts (53-54-30) (pict.3).

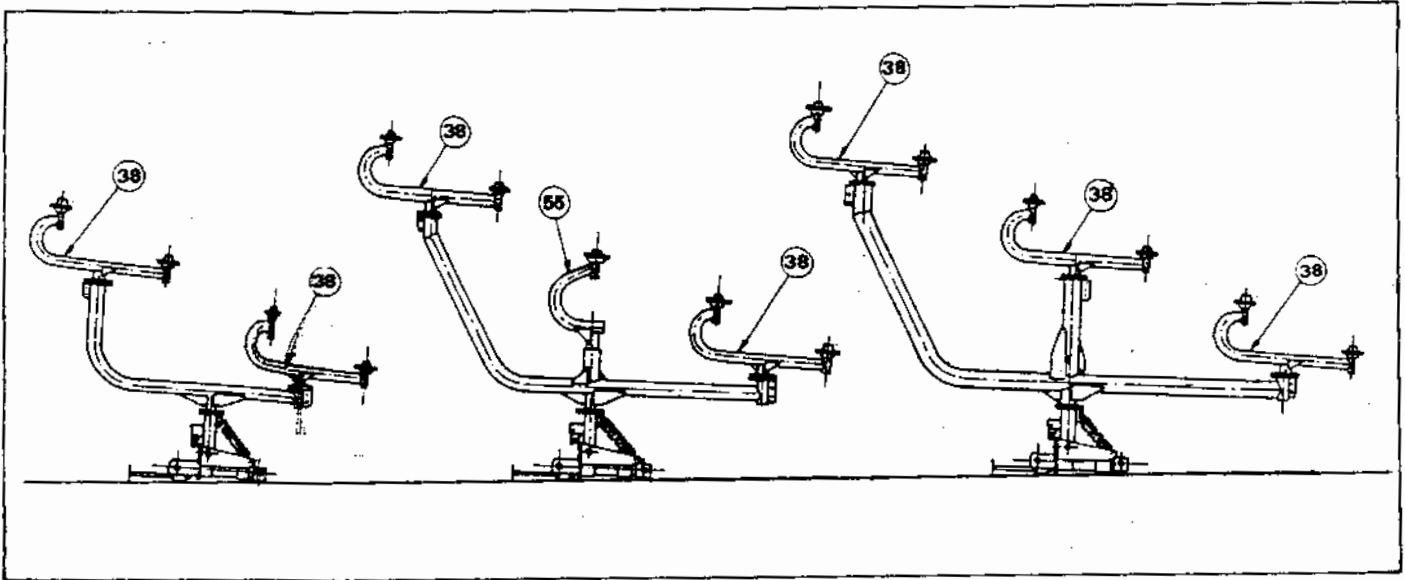

Pict. 3

- d) Attach the two central wheels (RP/4) or the three central wheels (RP/5) or the four central wheels (RP/6) to the supplied arm flanges (38-55) and bolt them with the supplied bolts (pict.4). when bolting the wheels (x) check that the tine clamps (48) are turned toward the hub.

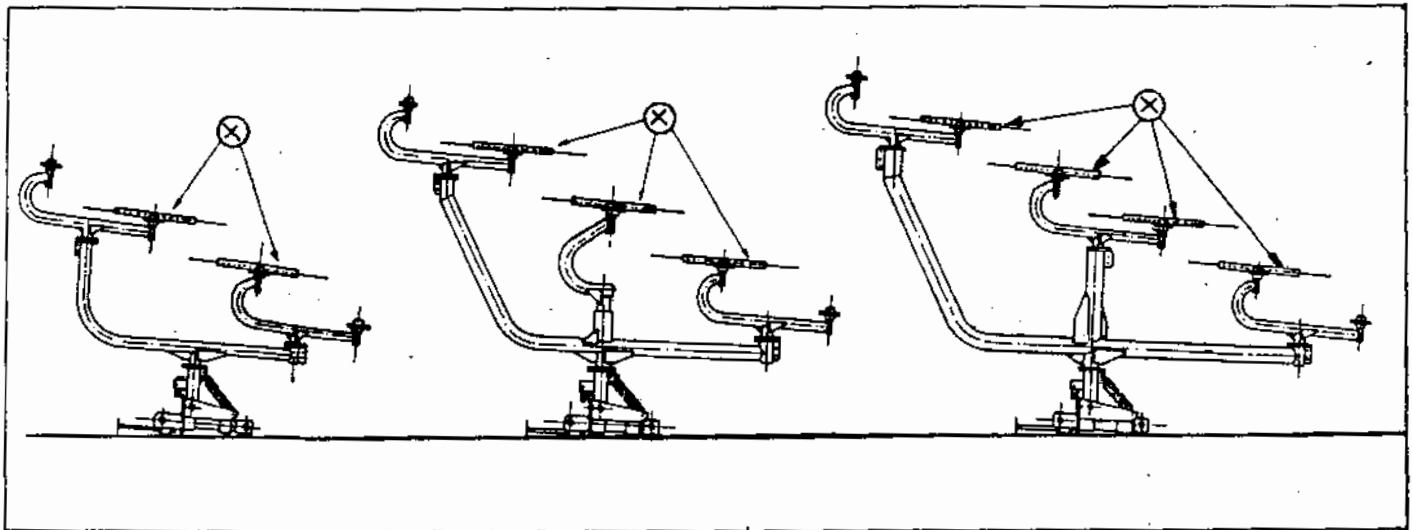

Pict. 4

- e) Lift the wheels (x) from the ground until they are in the working position (pict. 5).

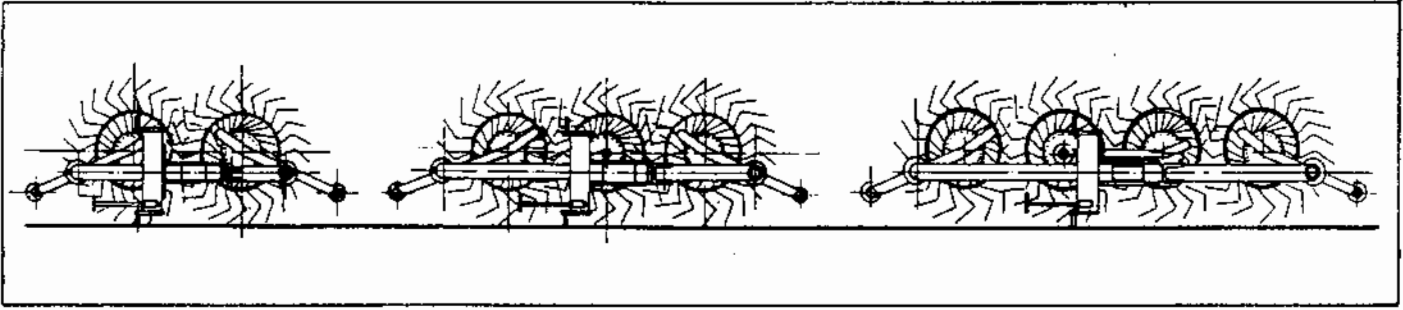

Pict. 5

- f) Unlock the primary structure with the supplied lever (33) and pin (36), turn it by 90 degrees and lock it again with the same pin. Now the rake is properly positioned on the ground and you only have to attach the remaining wheels as explained above.

The rake is now fully assembled and ready to be mounted to the tractor (pict. 6)

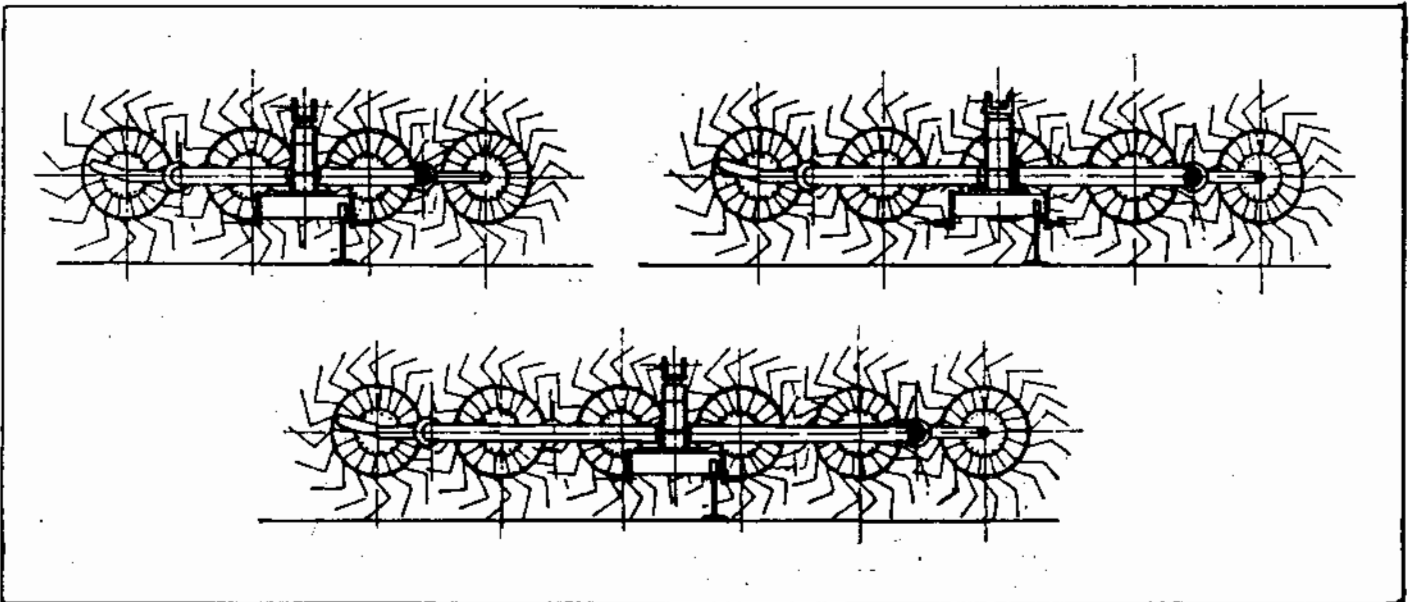

Pict. 6

IMPORTANT

Above are the instructions for the R.H. rake assembly. Please refer to the above instructions also for the L.H. rake assembly. Most parts are interchangeable for both rakes, only the specific parts are marked RIGHT or LEFT.

MOUNTING OF RP/4 AND RP/5 RAKE TO TRACTOR

When the rake is ready to be mounted to the tractor (pict. 6) attach the lifting arms to the pins on both sides of the primary structure (16).

Next, attach the three point arm to the cap (18) of the primary structure with the pin. Now lift the rake to its highest setting and for transport lock with the pin (32) for no rake floating (pict. 7).

Retain the part (17) to the crossbar (16) with the pin (19) into hole 1 (pict. 15) of the above said crossbar. Now turn the main pipe (37) and bring the rake to the vertical position for transport (pict. 8).

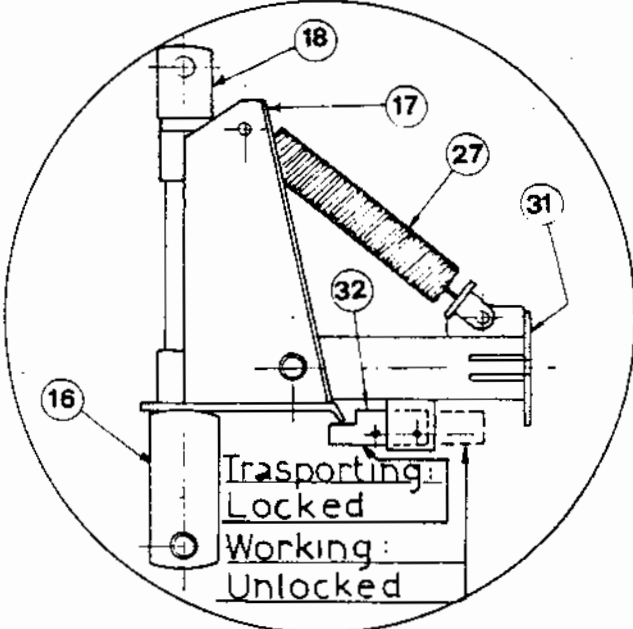

Pict. 7

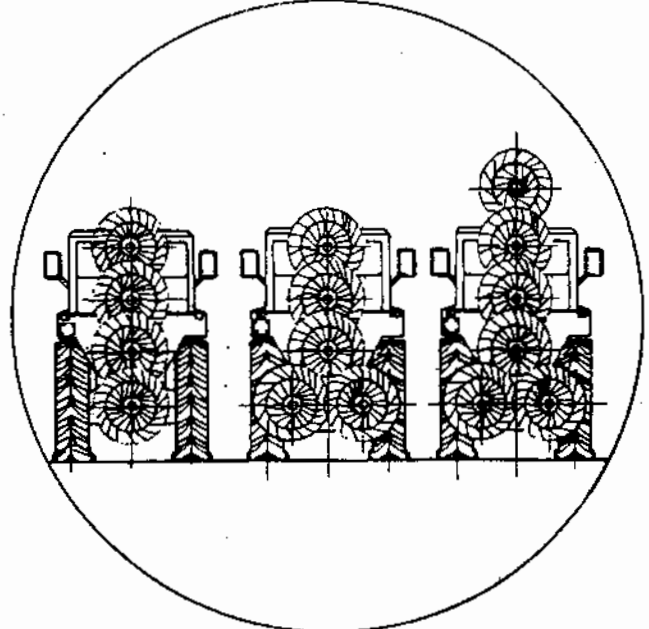

(Pict. 8)

VERY IMPORTANT

Never operate the rake with the pin (32) in the locked position. The locked position is for transport only (pict. 7).

RP/8-RP/10 AND RP/12 V-RAKE ASSEMBLY INSTRUCTIONS

RP/8 and RP/10 and RP/12 V-rakes are made as follows:

- no 1 main frame (1) complete of hitches (4-12)
- no 1 R.H. RP/4 or RP/5 or RP/6 rake, duly assembled as above.
- no 1 L.H. RP/4 or RP/5 or RP/6 rake, duly assembled as above.

IMPORTANT

On the R.H. and L.H. RP/4 and RP/5 and RP/6 rakes only the wheel arms and the wheels are specific, all other parts are interchangeable for both rakes. The specific parts are marked RIGHT (for the R.H. rake) and LEFT (for the L.H. rake).

ASSEMBLING

Attach the hitches (4-12) and relevant counterplates (5) to both ends of the main frame (1) - in the position show in picture 9 - with bolts (6-7-8)

Attach hitches (4-12) to the opposite side of the tractor's hitches welded on the frame (1) (pict. 10).

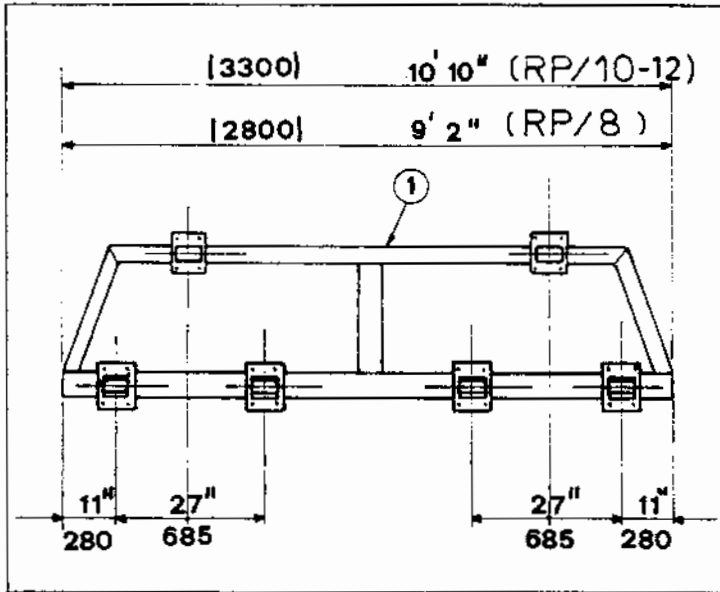

(Pict. 9)

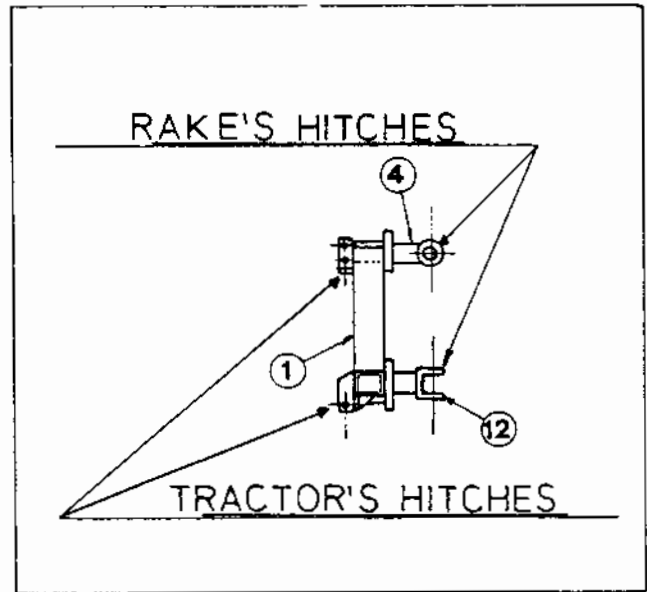

(Pict. 10)

Next, manually (pict. 11) or with a crane (pict. 12) lift the main frame (1) and bolt it to the tractor's lifting arms.

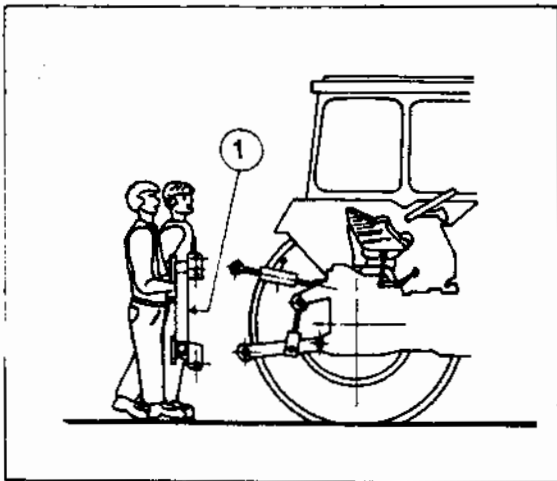

(Pict. 11)

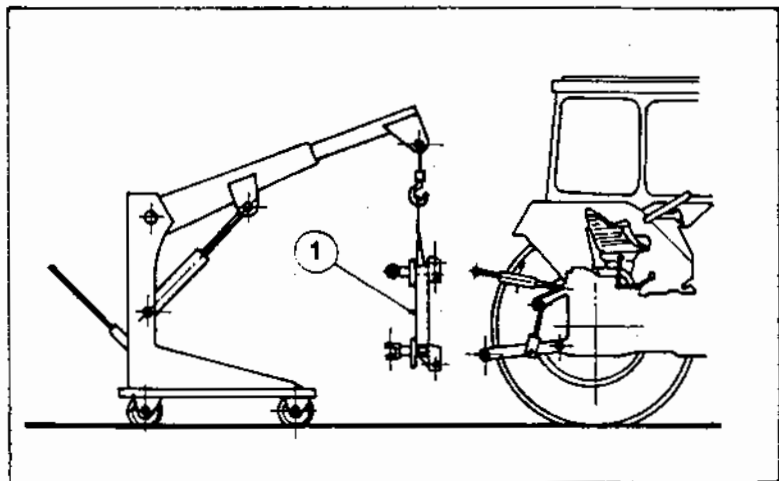

(Pict. 12)

ATTACHING THE RAKES TO THE FRAME

Attach hitches (12) of frame (1) to the lateral pins welded on the primary structure (16) of rake with the pins (11) and the split pins (10). Attach the upper hitch (4) to the cap (18) with the pin (9) and the split pin (10).

IMPORTANT

For the V-rake transport please refer to the RP/4 and RP/5 and RP/6 rake transport. Pictures 13 and 14 below show the transport position of RP/8 and RP/10 and RP/12 V-rakes.

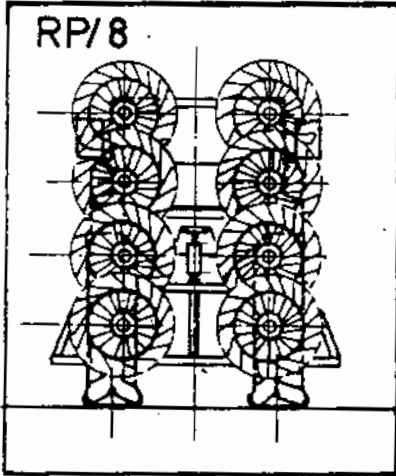

13

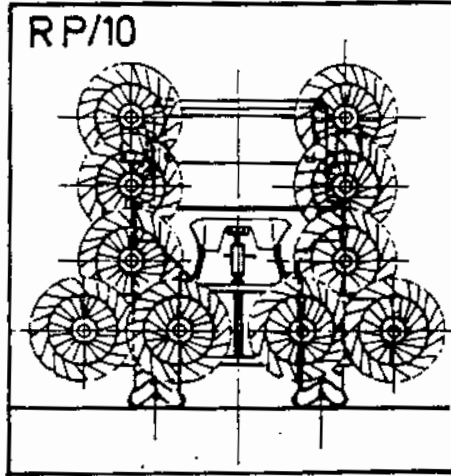

Pict. 13

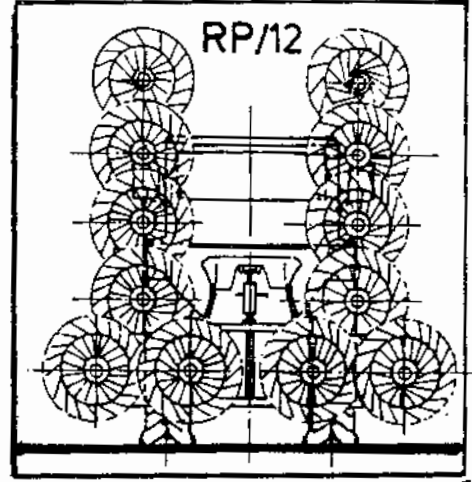

Pict. 14

ON THE FIELD

Before operating the rake and after you have reached the field, unlock pin (32) (pict. 7 and relevants notes). This will enable the rake to float independent of the main frame.

Next, adjust the rake working angle by positioning the pin (19) into the holes 2 to 7 (pict. 15). Hole 1 is for transport only.

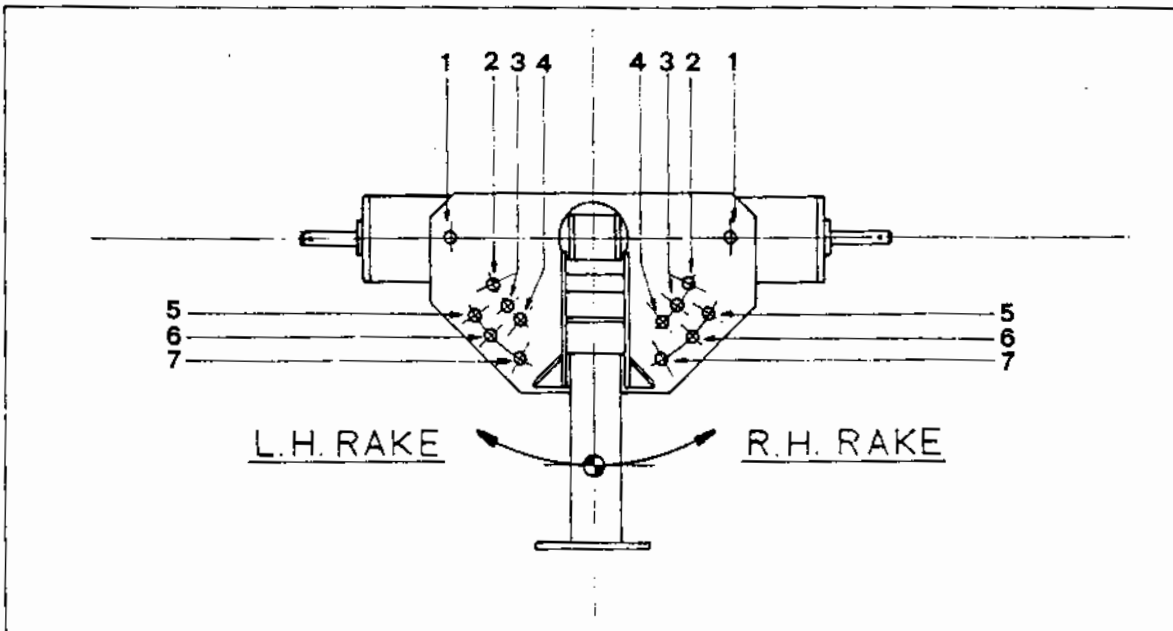

Pict. 15

The rake is suitable for:

1) RAKING (pict. 16)

Turn the main pipe (37) with the bend to the left.

Turn the wheel arms (38) (on RP/5 rake turn the wheel arm 55 as well) with the bend to the left.

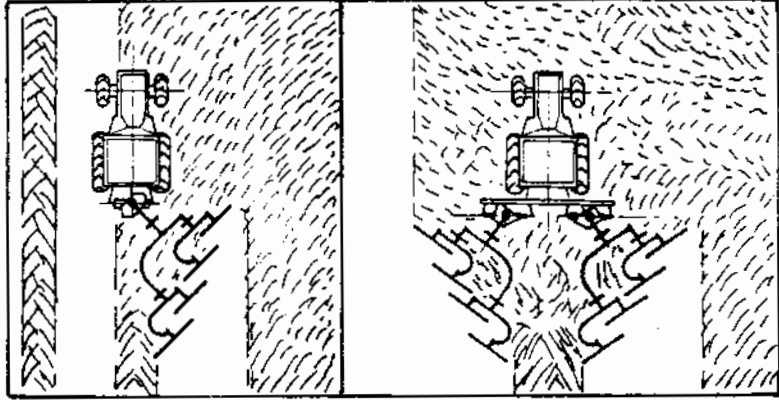

Pict. 16

2) SPREADING (pict. 17)

Turn the main pipe (37) with the bend to the left.

Turn the wheel arms (38) (on the RP/5 rake turn the wheel arm 55 as well) with the bend to the right.

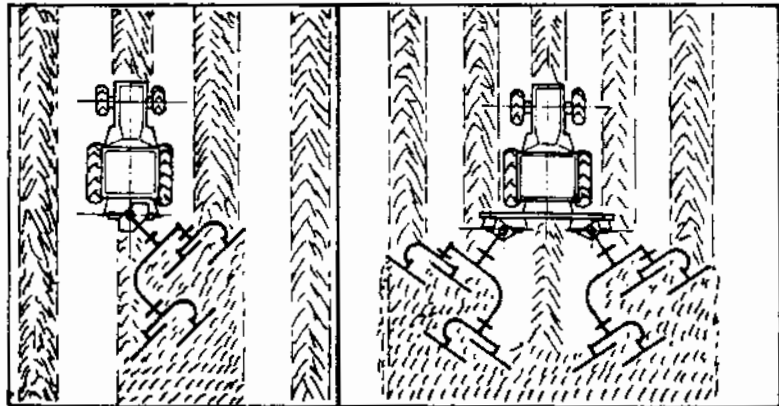

Pict. 17

3) TURNING (pict. 18)

Turn the main pipe (37) with the bend to the right.

Turn the wheel arms (38) (on RP/5 rake turn the wheel arm 55 as well) with the bend to the left.

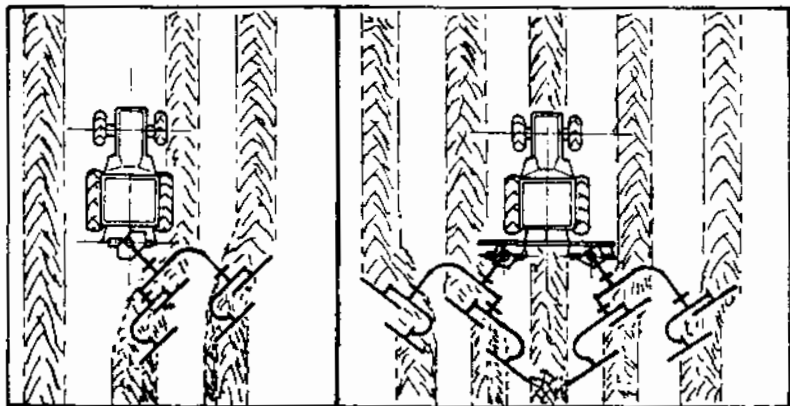

Pict. 18

IMPORTANT

Above we have described how to set a R.H. rake for the different operations. If you need to set a L.H. rake for the above operations, please refer to pictures 16-17 and 18 of V-rakes.

ON THE FIELD WITH RP/8-RP/10 AND RP/12 V-RAKES

RP/8 and RP/10 and RP/12 V-rakes are properly designed for windrowing, as ideal implement to complement the big balers. Slide the RP/4 or RP/5 or RP/6 rakes on the frame (1) to get different working widths.

Below (pict. 19-20) the ideal positioning of the rake for a swath suitable for a 5' pick-up baler.

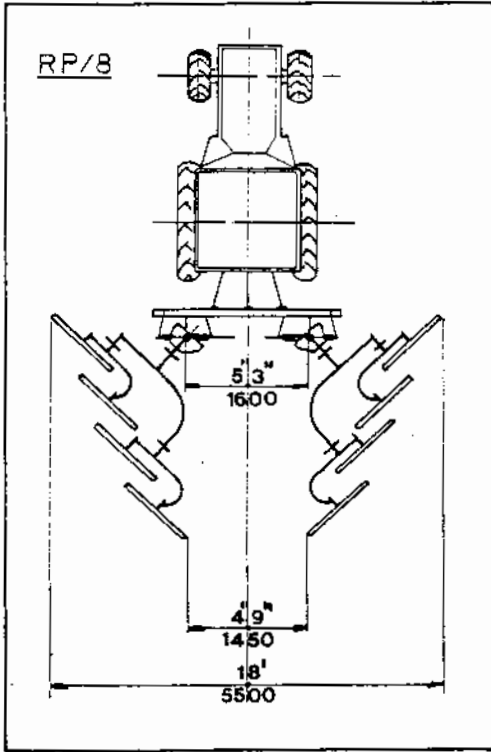

19

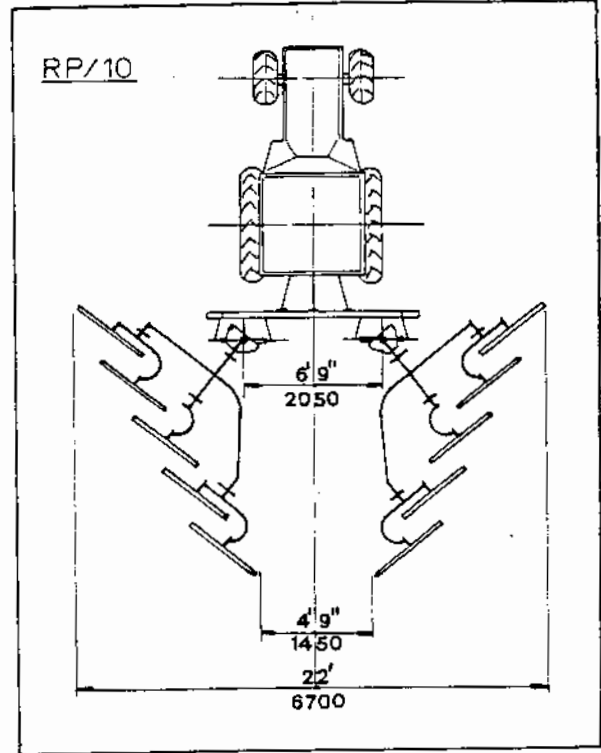

20

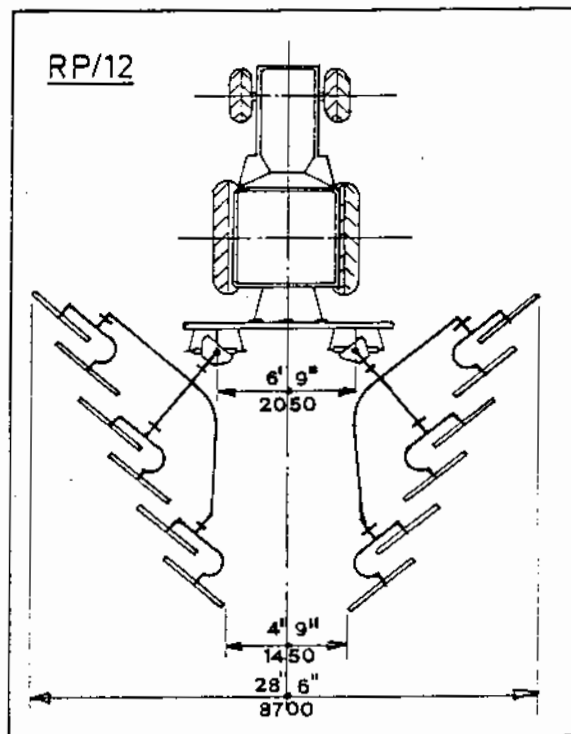

FEATURES

Hayrakes are basically made of a primary structure of bent steel pipes, which make the implement particularly sturdy and flexible. Tines are also very flexible, many are the possible adjustments of the rake, and the implement can work fast and successfully even on slopes or on stony and rough soils.

The wheel hubs are made of pressed steel and are equipped with taper roller bearings, protected with a dust cover, so that the wheels can properly turn.

MAINTENANCE

On hayrakes no maintenance is required. As a matter of fact no maintenance is required for all gearings, wheel hubs (equipped with 1st quality taper roller bearings and protected with a dust cover) and all setting operations.

No special tools are therefore required for servicing.

However, when the season is over, we recommend to clean the implement, to protect it from rust by oiling and store it until next season.

IMPORTANT

Every hayrake is provided with an identification label, as follows:

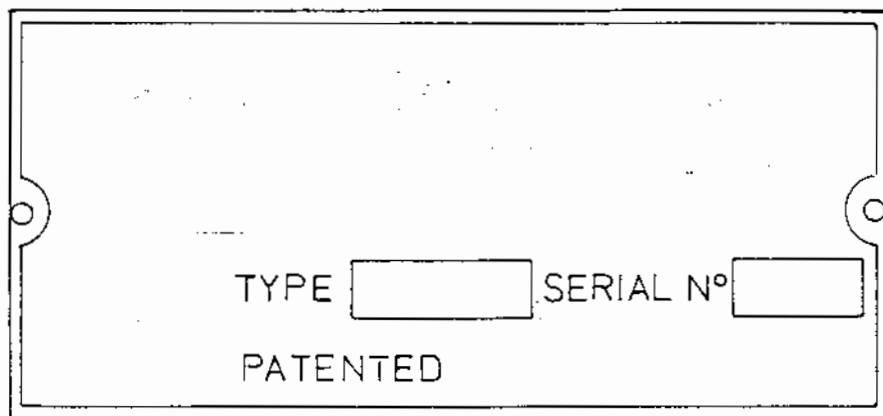

We recommend the use of original spare parts only, to get your implement working well for a long time. By ordering spare parts please always refer to the parts breakdown provided with this manual.

TROUBLES	CAUSES	REMEDIES
1) Wheel does not unload hay	1) New tine, too much paint on it. 2) Mud on tine point due to moist soil.	1) Have the wheels be turning on gravelly soil until the tine is clean again. 2) The wheels are too close to the ground
2) Tine failure	1) Going backwards with wheels not lifted. 2) Too much pressure on the wheels. 3) Tine rusted.	1) Lift the wheels before going backwards. 2) Lightly lift the rake. 3) Protect it by oiling.
3) The rake does not collect the hay	1) The wheel is too much inclined to the ground. 2) Tine worn out.	1) By setting the 3rd point arm, bring the wheel vertical to the ground. 2) Replace it. We recommend to replace all tines for uniform height.
4) Too much floating of wheels.	1) Wheels too far from ground.	1) Lightly lower the rake.
5) Bent tine	1) Going backwards with the wheels not lifted. 2) Too much speed on rough soil. 3) Going across deep and narrow ditches or prominences. 4) Too much weight on the wheels.	1) Lift the wheels when going backwards 2) Reduce speed. 3) Reduce speed. 4) Lightly lift the rake.

RP/4 RAKE
 RP/8 V-RAKE
 TABLE NO. 920.043

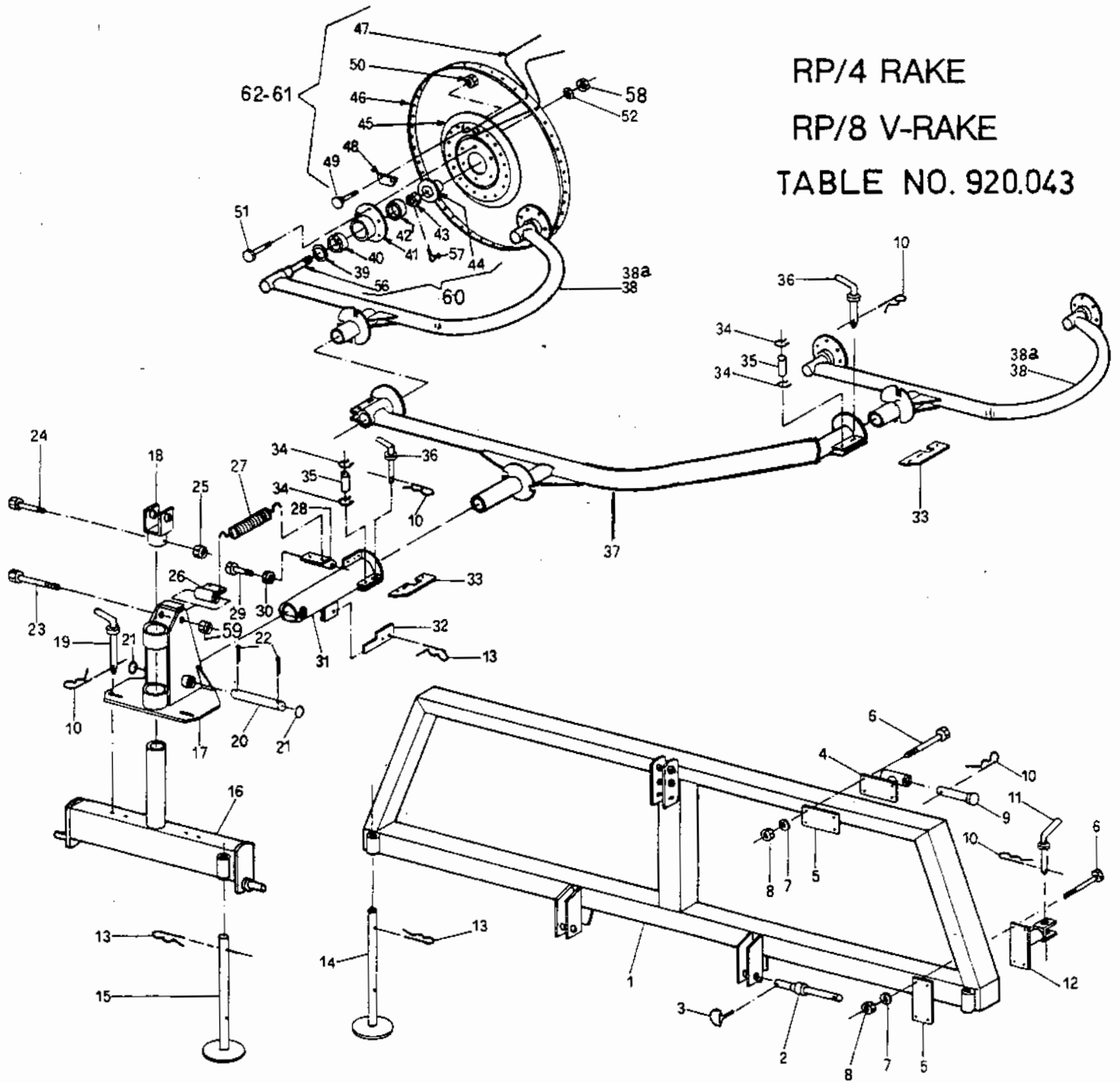
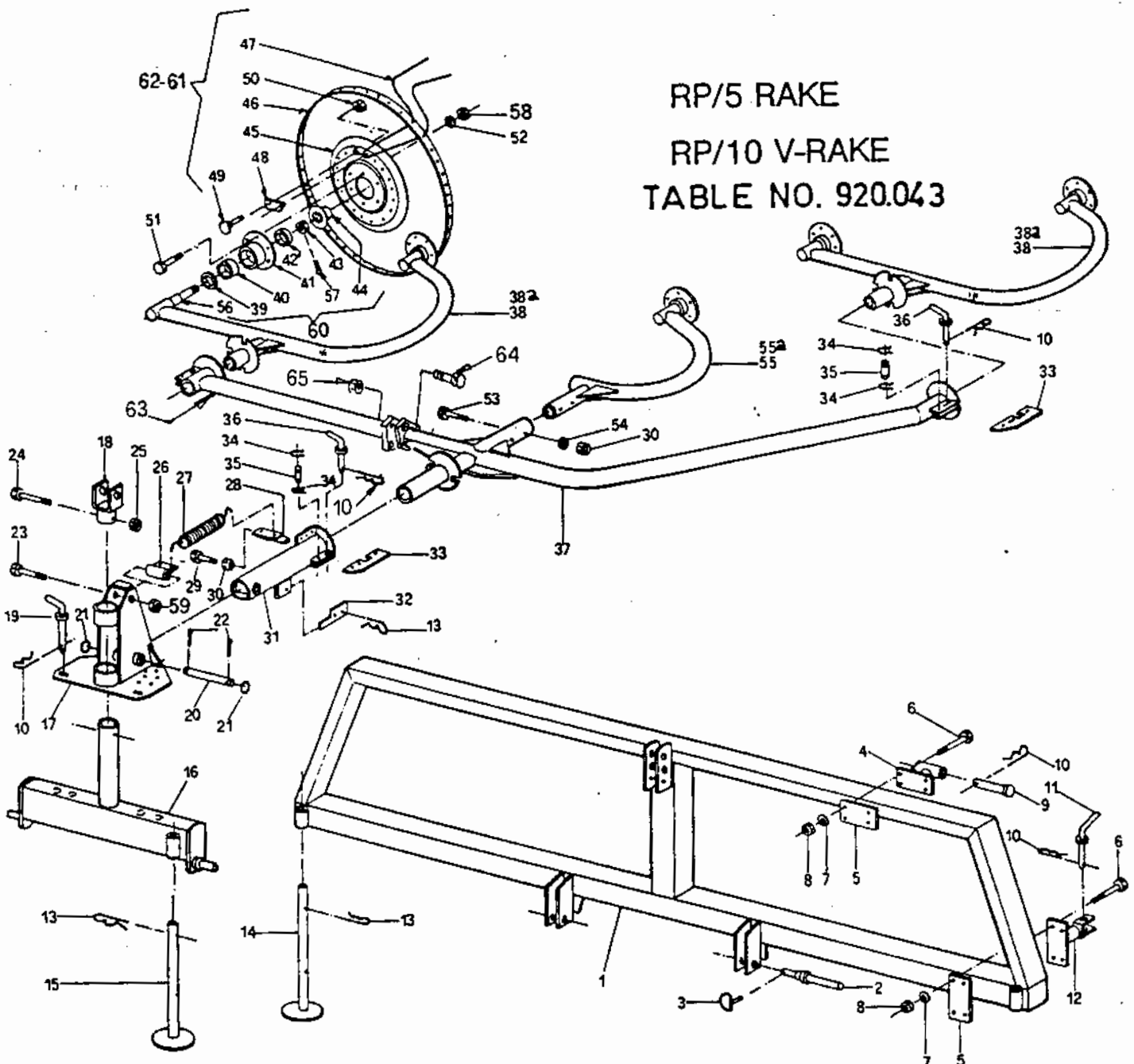
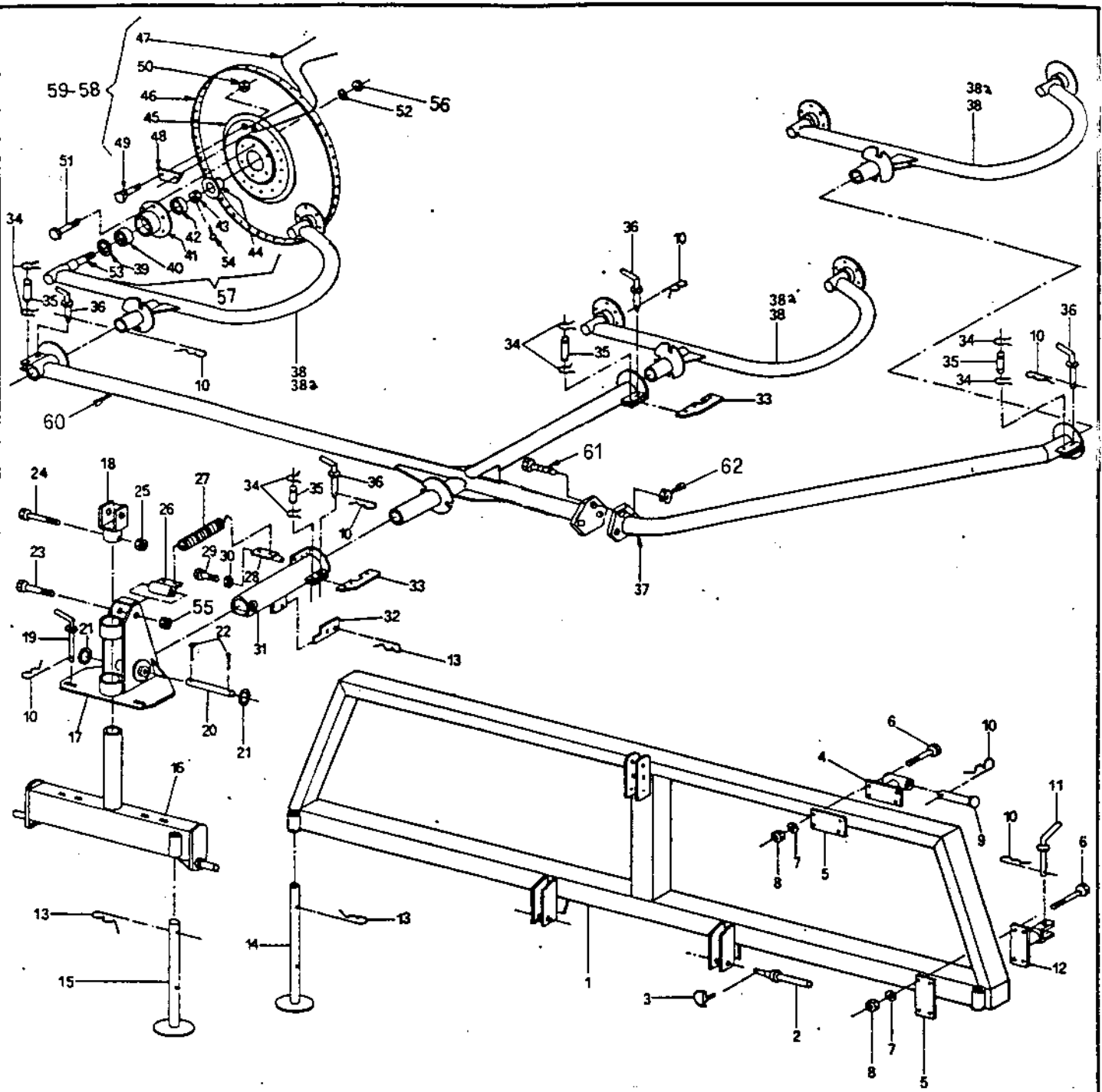

TABLE NO. 920.043				16	1	210.369	BASE
RP/4-RP/5-RP/6-RP/8-RP/10-RP/12				17	1	200.064	SUPPORT
ITEM	Q.ty	PART NO	DESCRIPTION	18	1	200.065	CAP
1	1	200.055	RP/8 FRAME	19	1	200.035	PIN
1	1	200.081	RP/10 FRAME	20	1	200.067	PIN
2	2	200.047	PIN	21	2	600.021	WASHER
3	2	600.017	SPLIT PIN	22	2	600.022	SPLIT PIN
4	2	200.056	UPPER LINKAGE	23	1	610.018	SCREW
5	6	200.057	COUNTERPLATE	24	1	600.003	SCREW
6	24	600.001	SCREW	25	1	600.051	NUT
7	24	600.018	SPRING WASHER	26	1	200.068	UPPER LINKAGE,SPRING
8	24	600.008	NUT	27	2	200.069	SPRING
9	2	200.058	3RD POINT HITCH	28	1	200.070	LOWER LINKAGE,SPRING
10	10	600.019	SPLIT PIN	29	1	600.004	SCREW
11	4	200.059	PIN	30	3	600.052	NUT
12	4	200.060	LOWER LINKAGE	31	1	200.071	SWINGING PIPE
13	4	600.020	SPLIT PIN	32	1	200.072	LOCK DEVICE
14	2	200.061	PARKING STAND,FRAME	33	3	200.073	LEVER
15	1	200.062	PARKING STAND,BASE	34	6	600.023	SNAP RING

RP/5 RAKE
 RP/10 V-RAKE
 TABLE NO. 920.043



35	3	200.074	PIN				
36	3	200.075	PIN				
37	1	210.571	RP/4 MAIN PIPE				
37	1	210.199	RP/5 MAIN PIPE				
38	2	200.077	WHEEL ARM,RH				
38a	2	200.078	WHEEL ARM,LH				
39	-	600.011	DUST COVER	53	2	600.007	SCREW
40	-	600.012	BEARING	54	2	600.018	SPRING WASHER
41	-	600.013	WHEEL HUB	55	1	200.079	ARM,RH
42	-	600.014	BEARING	56	-	205.277	PIN
43	-	600.015	SELF LOCKING NUT	57	-	600.301	SPLIT PIN
44	-	600.016	SAFETY CAP	58	-	600.010	NUT
45	-	200.010	FLANGE	59	-	600.075	NUT
46	-	200.009	RIM	60	-	205.041	HUB ASSY
47	-	210.620	TINE DIA.0,256" (6,5 mm)	61	-	210.180	WHEEL ASSY,RH (TINE DIA 0,276") (7 mm)
47	-	210.621	TINE DIA.0,276" (7 mm)	61	-	210.181	WHEEL ASSY,LH (TINE DIA 0,276") (7 mm)
48	-	200.012	TINE CLAMP	62	-	210.182	WHEEL ASSY,RH (TINE DIA 0,256") (6,5 mm)
49	-	600.005	SCREW	62	-	210.183	WHEEL ASSY,LH (TINE DIA 0,256") (6,5 mm)
50	-	600.029	NUT	63	1	210.198	RP/5 PIPE
51	-	600.006	SCREW	64	3	600.310	SCREW
52	-	600.024	SPRING WASHER	65	3	600.075	NUT



RP/6 RAKE
 RP/12 V-RAKE

TABLE NO. 920.035

TABLE NO.920.035

RP/6-RP/12

ITEM	Q.ty	PART NO	DESCRIPTION	NOTE
1	1	200.081	FRAME	
2	2	200.047	PIN	
3	2	600.017	SPLIT PIN	
4	2	200.056	UPPER LINKAGE	
5	6	200.057	COUNTER PLATE	
6	24	600.001	SCREW	
7	24	600.018	SPRING WASHER	
8	24	600.008	NUT	
9	2	200.058	PIN	
10	11	600.019	SPLIT PIN	
11	4	200.059	PIN	
12	4	200.060	LOWER LINKAGE	
13	4	600.020	SPLIT PIN	
14	2	200.061	PARKING STAND, FRAME	
15	1	200.062	PARKING STAND, BASE	
16	1	210.376	BASE	
17	1	200.118	SUPPORT	
18	1	200.094	CAP	
19	1	200.035	PIN	
20	1	200.067	PIN	
21	2	600.021	WASHER	
22	2	600.022	SPLIT PIN	
23	1	610.018	SCREW	
24	1	600.003	SCREW	
25	1	600.051	NUT	
26	1	200.121	UPPER LINKAGE SPRING	
27	2	300.015	SPRING	
28	1	200.122	LOWER LINKAGE SPRING	
29	1	600.004	SCREW	
30	1	600.052	NUT	
31	1	210.849	SWINGING PIPE	
32	1	200.072	LOCK DEVICE	
33	4	200.073	LEVER	
34	8	600.023	SNAP RING	
35	4	200.074	PIN	
36	4	200.075	PIN	
37	1	210.601	PIPE	
38	3/6	200.077	WHEEL ARM RH	
38a	3/6	200.078	WHEEL ARM LH	
39	6/12	600.011	DUST COVER	
40	6/12	600.012	BEARING	
41	6/12	600.013	WHEEL HUB	
42	6/12	600.014	BEARING	
43	6/12	600.015	SELF LOCKING NUT	
44	6/12	600.016	SAFETY CAP	
45	6/12	200.010	FLANGE	
46	6/12	200.009	RIM	
47	240/480	210.620	TINE DIA.0,256" (6,5 mm)	
47	240/480	210.621	TINE DIA.0,276" (7 mm)	
48	60/120	200.012	TINE CLAMP	
49	120/240	600.005	SCREW	
50	120/240	600.029	NUT	
51	36/72	600.006	SCREW	
52	36/72	600.024	SPRING WASHER	
53	6/12	205.277	PIN	
54	6/12	600.301	SPLIT PIN	
55	1	600.075	NUT	
56	36/72	600.010	NUT	
57	6/12	205.041	HUB ASSY	
58	6/12	210.180	WHEEL ASSY,RH (TINE DIA 0,276")	(7 mm)
58	6/12	210.181	WHEEL ASSY,LH (TINE DIA 0,276")	(7 mm)
59	6/12	210.182	WHEEL ASSY,RH (TINE DIA 0,256")	(6,5 mm)
59	6/12	210.183	WHEEL ASSY,LH (TINE DIA 0,256")	(6,5 mm)
60	1	210.602	MAIN PIPE	
61	3	600.310	SCREW	
62	3	600.075	NUT	

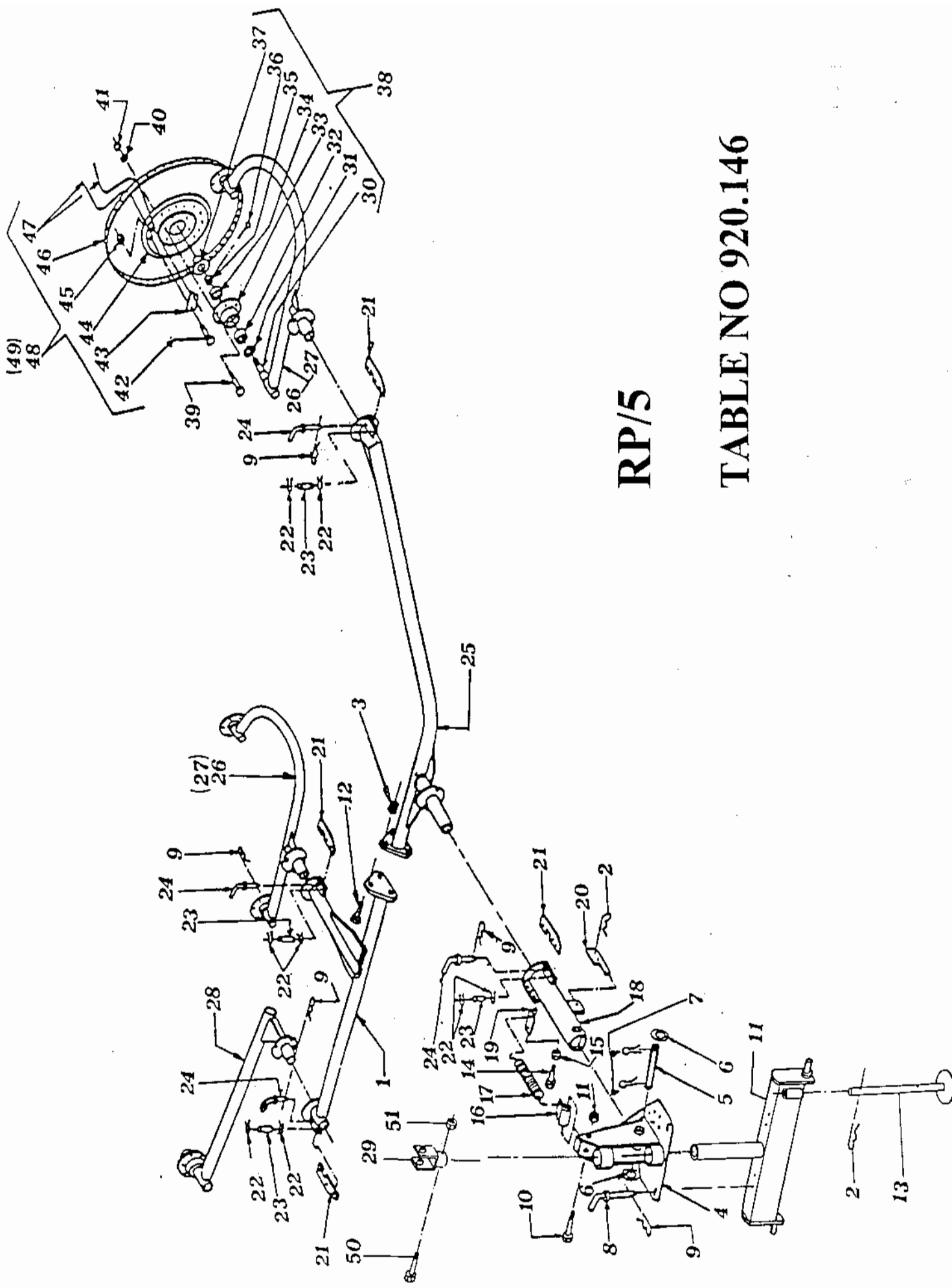

RP/5

TABLE NO 920.146

TABLE NO.920.146

RP/5					
ITEM	Q.ty	PART NO	DESCRIPTION	DESCRIPTION	NOTE
1	1	210.575	PIPE	PIPE	
2	2	600.020	SPLIT PIN	SPLIT PIN	
3	3	600.075	NUT	NUT M14 DIN 980	
4	1	200.064	SUPPORT	SUPPORT	
5	1	200.067	PIN	PIN	
6	2	600.021	WASHER	WASHER D 23 DIN 125A	
7	2	600.022	SPLIT PIN	SPLIT PIN	
8	1	200.222	PIN	PIN	
9	5	600.019	SPLIT PIN	SPLIT PIN	
10	1	610.018	SCREW	SCREW M14 X120 DIN 931 8.8	
11	1	210.369	BASE		
12	3	600.310	SCREW	SCREW M14 X 40 DIN 933 8.8	
13	1	200.062	PARKING STAND		
14	4	600.004	SCREW	SCREW M12 X 30 DIN 933 8.8	
15	1	600.008	NUT	NUT M12 DIN 934 - 8	
16	1	200.068	UPPER LINK/	UPPER LINKAGE, SPRING	
17	2	200.069	SPRING	SPRING	
18	1	200.071	SWINGING PI	SWINGING PIPE	
19	1	200.070	LOWER LINK/	LOWER LINKAGE, SPRING	
20	1	200.072	LOCK DEVICE	LOCK DEVICE	
21	4	200.073	LEVER	LEVER	
22	8	600.023	SNAP RING	SNAP RING E 15 DIN 471	
23	4	200.074	PIN	PIN	
24	4	200.075	PIN	PIN	
25	1	210.576	MAIN PIPE	MAIN PIPE	
26	2	200.077	WHEEL ARM,	WHEEL ARM, R.H.	
(27)	(2)	(200.078)	(WHEEL ARM	(WHEEL ARM, L.H.)	
28	1	210.067	ARM	ARM	
29	1	200.065	CAP		
30	5	205.277	PIN	PIN	
31	5	600.011	DUST COVER	DUST COVER	
32	5	600.012	BEARING	BEARING 30205	
33	5	600.013	WHEEL HUB	WHEEL HUB	
34	5	600.014	BEARING	BEARING 30204	
35	5	600.015	SELF-LOCKIN	SELF-LOCKING NUT M18X1,5 - 6	
36	5	600.301	SPLIT PIN	SPLIT PIN	
37	5	600.016	SAFETY CAP	SAFETY CAP	
38	5	205.041	HUB ASSY.	HUB ASSY.	
39	30	600.006	SCREW	SCREW M10 X 25 DIN 933 8.8	
40	30	600.024	SPRING WAS	SPRING WASHER D 10.5	
41	30	600.010	NUT	NUT M10 DIN 934 - 8	
42	100	600.005	SCREW	SCREW	
43	50	200.012	TINE CLAMP	TINE CLAMP	
44	5	200.010	FLANGE	FLANGE	
45	100	600.029	NUT	NUT M10 DIN 980	
46	5	200.009	RIM	RIM	
47	200	610.620	TINE DIA.0.25	TINE DIA.0.256" (6.5 mm)	
47	200	610.621	TINE DIA.0.27	TINE DIA.0.276" (7 mm)	
48	5	210.180	WHEEL ASSY	WHEEL ASSY., R.H.(TINE DIA.0.276" 7 mm)	
48	5	210.181	WHEEL ASSY	WHEEL ASSY., L.H.(TINE DIA.0.276" 7 mm)	
49	5	210.182	WHEEL ASSY	WHEEL ASSY., R.H.(TINE DIA.0.256" 6.5 mm)	
49	5	210.183	WHEEL ASSY	WHEEL ASSY., L.H.(TINE DIA.0.256" 6.5 mm)	
50	1	600.003	SCREW		
51	1	600.051	NUT		

simak[®]
MADE IN ITALY *srl*