

OPERATOR'S MANUAL

WP245 / WP275 3-Point Hitch Firewood Processor

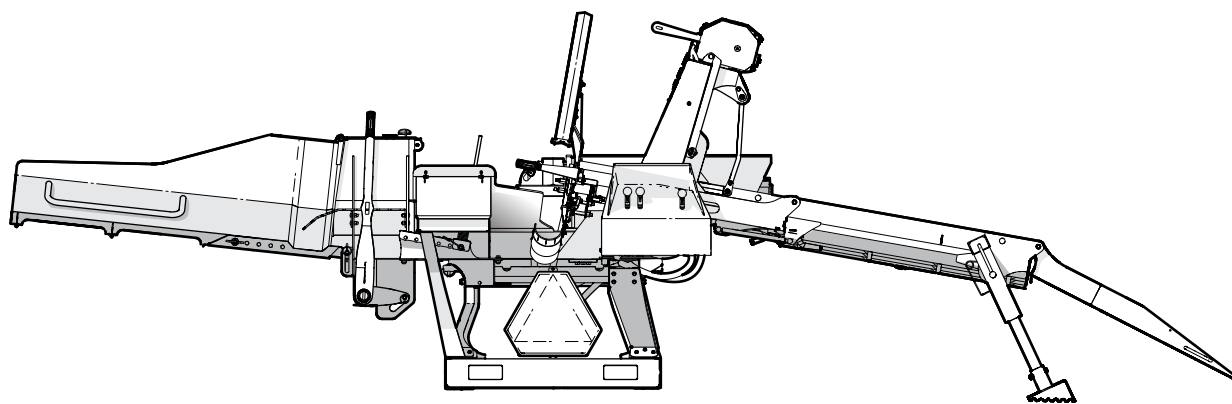

1. Foreword

1.1 Introduction

Congratulations on your choice of a Wallenstein Wood Processor!

This high-quality machine is designed and manufactured to meet the needs of a proficient timber or woodlot industry.

The Wallenstein Firewood Processor improves firewood productivity, ergonomics and minimizes handling while reducing the risk of physical strain.

This manual covers the WP245 and WP275 three-point hitch-mounted wood processors. The two models differ only in their splitter cradle capability:

Model	Split Opening
WP245	25" (61 cm)
WP275	36" (91 cm)

Keep this manual handy for frequent reference and to pass on to new operators or owners. Call your Wallenstein dealer or the Distributor if you need assistance, information, or additional copies of the manuals.

Units of measurement in Wallenstein Equipment technical manuals are written as:
US Customary (SI metric)

Wallenstein Equipment Inc. • © 2020. All rights reserved.

No part of this work may be copied, reproduced, replaced, distributed, published, displayed, modified, or transferred in any form or by any means except with the prior permission of Wallenstein Equipment Inc.

WARNING!

Do not attempt to start or operate the machine without thoroughly reviewing this manual for safe and proper operation.

Always keep this manual with the machine.

W034



www.wallensteinequipment.com

Table of Contents

1. Foreword	2	7. Service and Maintenance.....	39
1.1 Introduction.....	2	7.1 Fluids and Lubricants	39
1.2 Delivery Inspection Report.....	4	7.2 Greasing	40
1.3 Serial Number Location	5	7.3 Maintenance Schedule	41
1.4 Types of Decals on the Machine	6	7.4 Power Pack Option–Maintenance.....	42
2. Safety	7	8. Trouble Shooting	43
2.1 Safety Alert Symbol.....	7	9. Specifications	44
2.2 Signal Words.....	7	9.1 Machine Specifications.....	44
2.3 Why SAFETY is Important.....	7	9.2 Common Bolt Torque Values	45
2.4 Safety Rules.....	7	9.3 Hydraulic Fitting Torque.....	46
2.5 Equipment Safety Guidelines	8	10. Accessories.....	47
2.6 Creating a Safe Work Area.....	10	11. Product Warranty	48
2.7 Sign-Off Form	11	12. Alphabetical Index	49
2.8 Safety Sign Explanations	12		
3. Familiarization.....	16		
3.1 To the New Operator or Owner.....	16		
3.2 Job Site Familiarization	16		
3.3 Machine Components.....	17		
4. Controls	18		
4.1 Hydraulic Controls and Auto Cycle.....	18		
4.2 Winch Gear Lever	19		
4.3 Splitting Wedge Height Lever	20		
4.4 Adjustable Log Stop Guide.....	20		
4.5 Splitter Chute Height Adjuster	21		
5. Attaching / Unhooking	22		
5.1 Mounting.....	22		
5.2 Connecting Tractor Hydraulic Circuit.....	23		
5.3 Optional Power Pack, Connecting	24		
6. Operating Instructions	25		
6.1 Operating Safety.....	25		
6.2 Pre-Operation Checks.....	25		
6.3 Machine Set-Up	26		
6.4 Attaching Chain Saw to Holder.....	28		
6.5 Setting Log Stop Guide.....	29		
6.6 Starting	30		
6.7 Stopping	30		
6.8 Emergency Stopping	30		
6.9 Winching.....	31		
6.10 Cutting	34		
6.11 Splitting.....	34		
6.12 Next Log	35		
6.13 Last Log.....	36		
6.14 Efficient Processing.....	36		
6.15 Machine Break-In	36		
6.16 Transporting.....	37		
6.17 Storage	38		

1.2 Delivery Inspection Report

This form must be filled out by the dealer at the time of delivery, then signed by the dealer and customer.

Wallenstein WP245 / WP275 Three-point Hitch Mounted Firewood Processor

To activate warranty, register your product at:
www.wallensteinequipment.com

The product manuals have been received by me and I have been thoroughly instructed as to care, adjustments, safe operation, and applicable warranty policy.

I have thoroughly instructed the buyer on the equipment care, adjustments, safe operation, and applicable warranty policy and reviewed the manuals.

Customer

Dealer

Address

Address

City, State/Province, ZIP/Postal Code

City, State/Province, ZIP/Postal Code

()

()

Phone Number

Phone Number

Contact Name

Model

Serial Number

Delivery date

1.2.1 Dealer Inspection Report

- _____ All Valve Controls Function
- _____ All Cylinders and Winch Motor Functions
- _____ Wedge Height Adjuster Functions
- _____ Loader and Lead-in chutes fold up and latch securely.
- _____ Log Stabilizer moves freely.
- _____ All Fasteners Tight
- _____ Pivot points lubricated.
- _____ Hydraulic Connections Tight.
- _____ Check winch clutch handle control function.
- _____ Check winch rope / hook / fairlead

- _____ Grease Machine
- _____ Operating and Safety Instructions Reviewed

Safety Checks

- _____ All safety decals installed.
- _____ Guards and shields installed and secured.
- _____ Retainer installed through hitch points.

1.3 Serial Number Location

Always provide the serial number of your Wallenstein product when ordering parts or requesting service or other information.

The Serial Number Plate location is shown in the illustration. **For future reference, record your product Serial Number in the space provided below.**

Record Product Information Here	
Model:	
Serial Number:	

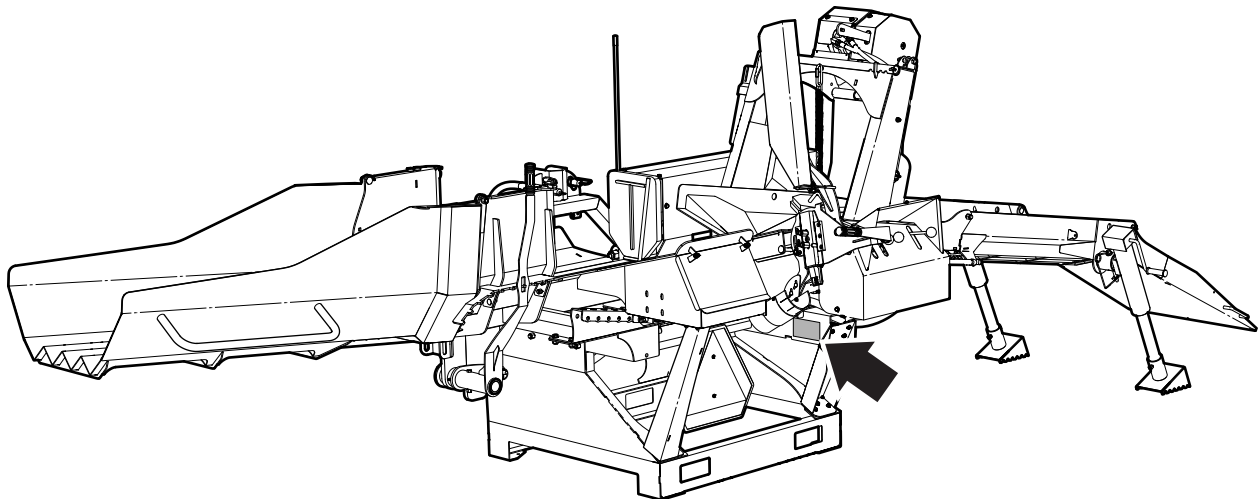
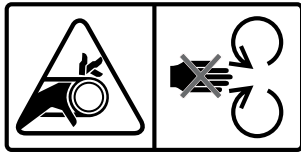

Fig. 1 – Serial Number Plate Location (Typical)

1.4 Types of Decals on the Machine

When getting familiar with the Wallenstein product, notice that there are numerous decals located on the machine. There are different types of decals for safety, information, and product identification. The following section explains what they are for and how to read them.

Safety Decals have a yellow background and are generally two panel. They can be either vertical or horizontal.



Safety Notice Decals are pictorial with a blue background and generally rectangular with single or multiple symbols. This decal informs what Personal Protective Equipment is required for safe operation.



Informative Decals are generally pictorial with a white background and can vary in the number of panels. This type of decal explains how a control works.

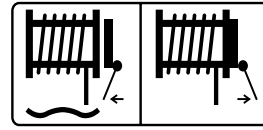

Product Decals indicate machine model and serial number, and other important information.

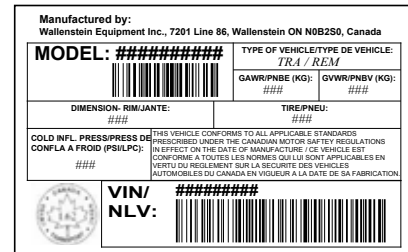

Maintenance Decals have a green background and can vary to the number of panels. This decal shows a type maintenance required and frequency interval.

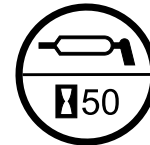

See the section on safety signs for safety decal definitions. For a complete illustration of decals and decal locations, download the parts manual for your model product at www.wallensteinequipment.com.

2. Safety

2.1 Safety Alert Symbol

This Safety Alert Symbol means:

ATTENTION! BE ALERT!

YOUR SAFETY IS INVOLVED!

The Safety Alert Symbol identifies important safety messages on the Wallenstein Wood Processor and in the manual.

When you see this symbol, be alert to the possibility of personal injury or death. Follow the instructions in the safety message.



2.2 Signal Words

The signal words **DANGER**, **WARNING** and **CAUTION** determine the seriousness level of the warning messages in this manual. The appropriate signal word for each message in this manual has been selected using the following guidelines:

DANGER –

Indicates an imminently hazardous situation that, if not avoided, **will** result in death or serious injury. This signal word is to be limited to the most extreme situations typically for machine components which, for functional purposes, cannot be guarded.

WARNING –

Indicates a potentially hazardous situation that, if not avoided, **could** result in death or serious injury, and includes hazards that are exposed when guards are removed. It may also be used to alert against unsafe practices.

CAUTION –

Indicates a potentially hazardous situation that, if not avoided, **may** result in minor or moderate injury. It may also be used to alert against unsafe practices.

IMPORTANT – To avoid confusing equipment protection with personal safety messages, a signal word **IMPORTANT** indicates a situation that if not avoided, could result in damage to the machine.

2.3 Why SAFETY is Important

Three Big Reasons:

- Accidents can disable and kill
- Accidents can cause financial hardship
- Accidents can be avoided

YOU are responsible for the SAFE operation and maintenance of your Wallenstein wood processor. **YOU** must ensure that you and anyone else who is going to use, maintain or work around the wood processor be familiar with the operating and maintenance procedures and related **SAFETY** information contained in this manual. This manual provides good safety practices that should be followed while using this machine.

Remember, **YOU** are the key to safety. Good safety practices not only protect you but also the people around you. Make these practices a working part of your safety program. Be certain that **EVERYONE** using this equipment is familiar with the recommended operating and maintenance procedures and follows all the safety precautions. Most accidents can be prevented.

Do not risk injury or death by ignoring good safety practices.

2.4 Safety Rules

- It is the operator's responsibility to read, understand and follow ALL safety and operation instructions in this manual. If you do not understand any part of this manual and require assistance, contact your dealer, distributor, or Wallenstein Equipment.



- Do not allow anyone to use this machine until they have read this manual. Operator's must have a thorough understanding of the safety precautions and of how the machine works. Review the safety instructions with all users annually.
- The operator of this wood processor must be a responsible, physically able person familiar with machinery and trained in this machine's operation.
- Provide instructions to anyone else who is going to operate the machine. This equipment is dangerous to anyone unfamiliar with its operation.
- Review safety related items annually with all personnel who will be operating or performing maintenance.
- Make sure all safety signs on the machine are understood before operating, servicing, adjusting, or cleaning. Safety sign explanations begin on *page 39*. Replace any safety sign or instruction sign that is not readable or is missing. Being unfamiliar with a machine can lead to injuries.
- Never exceed the limitations of the machine. If its ability to do the job, or to do it safely is in question—**STOP!**
- Inspect and secure all guards before starting.
- Do not modify the equipment in any way. Unauthorized modifications may affect the integrity of the machine or the ability of the machine to perform as designed. Modifications can impair safety or function. They can affect the life of the equipment and void warranty.
- Have a first-aid kit available for use should the need arise.
- Have a fire extinguisher available for use should the need arise and know how to use it.
- Check the machine is clear of debris prior to starting the tractor engine.
- Handle logs with respect and be aware of other personnel in the area.
- Always wear appropriate PPE. This equipment includes but is not limited to the following:
 - A hard hat
 - Heavy gloves
 - Hearing protection
 - Protective shoes with slip resistant soles
 - Protective glasses, goggles, or face shield



- The best safety feature is an informed, careful operator—we ask you to be that kind of an operator. It is the operator's responsibility to read, understand and follow ALL safety and operation instructions in the manual. Accidents can be avoided.

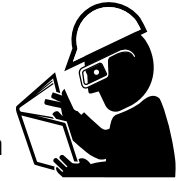

- Train all operators to be familiar with equipment's operation. The operator should be a responsible, properly trained and physically able person familiar with machinery. If the elderly are assisting with work, their physical limitations need to be recognized and accommodated.

- Wear hearing protection on a full-time basis. Prolonged exposure to loud noise may cause permanent hearing loss!
 - Noise over 85 dB on a long-term basis can cause severe hearing loss.
 - Noise over 90 dB adjacent to the Operator over a long-term basis may cause permanent, total hearing loss.



2.4.1 Safe Condition

Throughout this manual, we talk about a 'Safe Condition'. What this means is parking the machine in a manner that makes it safe to service or repair.

Place the machine in a Safe Condition before performing any service, maintenance work or storage preparation by performing the following:

SAFE CONDITION
<ol style="list-style-type: none"> 1. Clear infeed conveyor and splitting hopper. 2. Wind in winch rope. 3. Release all controls and ensure all components have stopped moving. 4. Shut off the engine. 5. Relieve hydraulic system pressure by actuating controls. 6. Make sure parking brake is applied and chock wheels to prevent movement.

2.5 Equipment Safety Guidelines

The safety of the operator and bystanders is one of the main concerns in designing and developing equipment. However, every year many accidents occur which could have been avoided by a few seconds of thought and a more careful approach to handling equipment.

- Do not allow anyone to use this machine until they have read this manual and have developed a thorough understanding of the safety precautions and of how it works. Review the safety instructions with all users annually.
- Never exceed the limitations of the machine. If its ability to do the job, or to do it safely is in question—**STOP!**

2.5.1 Hydraulic System Safety

- Make sure that all the components in the hydraulic system are kept clean and in good condition.
- Make sure all components are tight, and that lines, hoses and couplings are not damaged before applying pressure to the system.
- Do not use a hand to check for hydraulic oil leaks. Hydraulic fluid escaping under pressure can penetrate the skin causing serious injury. Use a piece of cardboard.



- Wear proper hand and eye protection when searching for a high-pressure hydraulic leak.

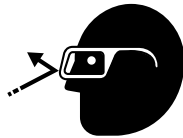

- Seek medical attention immediately if injured by a concentrated high-pressure stream of hydraulic fluid. Serious infection or toxic reaction can develop from hydraulic fluid piercing the skin surface.
- Do not attempt any makeshift repairs to the hydraulic lines, fittings, or hoses by using tape, clamps, or cements. Doing so can cause sudden failure and create a hazardous and unsafe condition.
- Relieve pressure on the hydraulic system before working it. The hydraulic system operates under extremely high pressure.
- Replace any hydraulic hose immediately that shows signs of swelling, wear, leaks, or damage before it bursts.
- Do not bend or strike high-pressure lines, tubes, or hoses, or reinstall them in a bent or damaged condition.
- Check to make sure hydraulic hoses are not worn or damaged and are routed to avoid chafing.
- Never adjust a pressure relief valve or other pressure-limiting device to a higher pressure than specified.

2.5.2 Chain Saw Safety

A chain saw is inherently hazardous. Potential injuries can be minimized by using proper personal protective equipment and safe operating procedures. **Always read the safety section in your chain saw owner's manual.**

Good cutting action results and chain life increases with correct chain tension. If too loose, a chain can derail; if too tight a chain can bind.

Proper chain lubrication prolongs the life of the saw and increases safety.

Sharpen the saw if:

- The chain tends to track sideways while cutting.
- The cut shows fine powder instead of chips.
- There is a burnt wood smell.

Never use a saw chain that:

- Has broken twice.
- Is severely damaged.
- Has excessive saw chain stretch.
- Has broken or cracked components.
- Has loose rivet joints. If you can rotate the rivets with your fingers, they are too loose.

2.6 Creating a Safe Work Area

The three-point hitch mounted WP200 Series Wood Processors are designed to winch, cut to length, and split logs for firewood. Review and follow safe operating and winching safety instructions in this manual. Also review the safety guidelines included with your chain saw.

Below is an example of a safe work area. Not all work areas are the same, but the principles presented here can be applied to any work area.

Follow these important points to keep bystanders and workers safe from hazards.

- Establish a Safe Zone perimeter around the work area and mark with safety cones. The perimeter should be at least 10 ft (3 m) from any hazard within the work area.
- Never allow workers or bystanders to approach the processor while in operation without first signaling the operator.
- Keep all bystanders in the Safe Zone and never allow them in the Hazard or Work zones.
- Always operate the processor controls from the Operator Zone located at the control panel.
- Only the operator can authorize entry into the Hazard Zone. The operator must first ensure it is safe to enter.

- Always be aware of coworkers. Make eye contact and have a hand signal scheme worked out.
- Use extreme caution around the material stacks. Stacked logs could roll in unpredictable ways.
- Be aware of split wood stacks. Split wood can tumble off the pile.

The safe work area is divided into four zones:

- 1. Safe Zone** – This is the area outside the work area perimeter for bystanders or anyone not directly involved with the work. The Safe Zone has minimal potential hazards.
- 2. Work Zone** – Workers helping the operator wearing the appropriate PPE are allowed in this area. The Work Zone is outside of the Hazard Zone with limited hazards.
- 3. Hazard Zone** – Only workers are allowed in the Hazard Zone and must always make eye contact with the operator before entering. Unauthorized workers or bystanders are not allowed in the Hazard Zone, due to the risks present.
- 4. Operator Zone** – Only the operator should be in the Operator Zone.

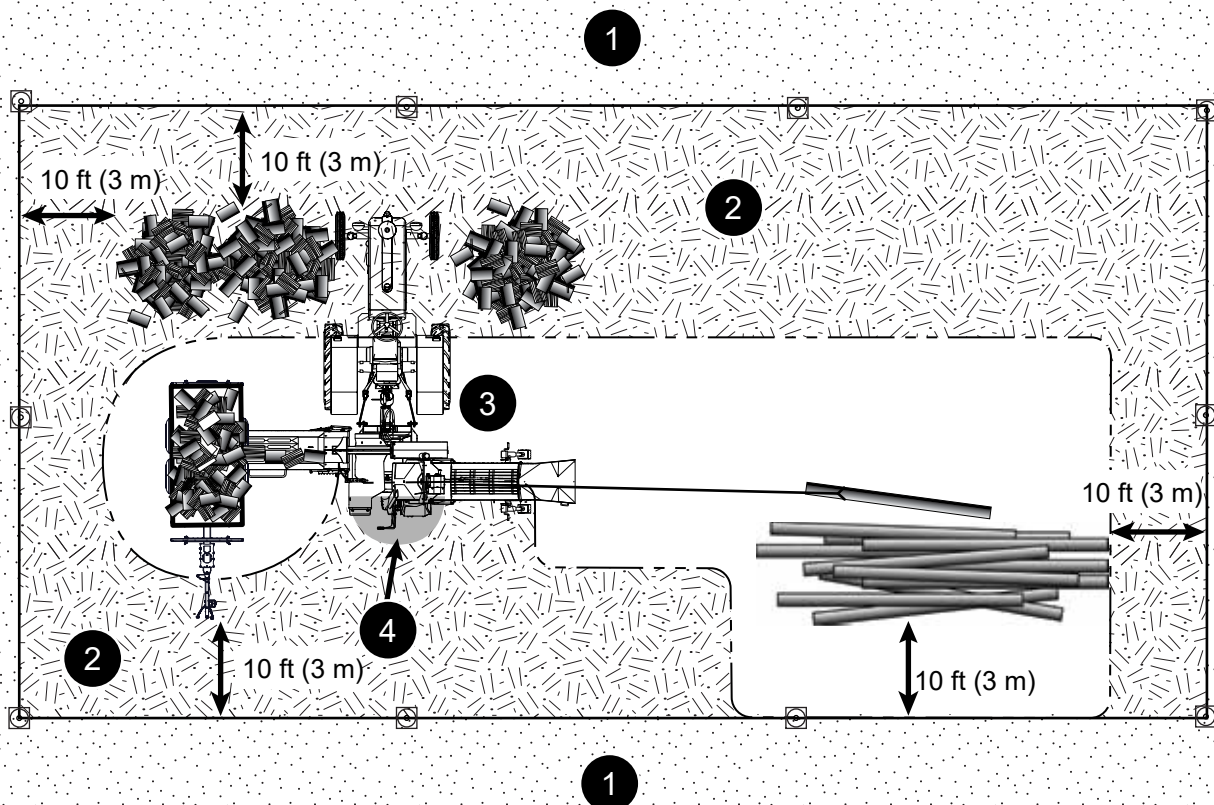

Fig. 2—Safe Work Area

2.7 Sign-Off Form

Wallenstein follows the general Safety Standards specified by the American Society of Agricultural and Biological Engineers (ASABE). Anyone who will be using and/or maintaining the Wood Processor must read and clearly understand ALL Safety, Usage and Maintenance information presented in this manual.

Do not use or allow anyone else to use this Wood Processor until such information has been reviewed. Annually review this information before the season start-up.

Make these periodic reviews of SAFETY and OPERATION a standard practice for all your equipment. We feel that an untrained operator is unqualified to use this machine.

A sign-off sheet is provided to record all personnel who will be working with the equipment have read and understand the information in the Operator's Manual and have been instructed in the operation of the equipment.

Sign-off Form		
Date	Owner	Employee

2.8 Safety Sign Explanations

The top (or left-hand) panel shows the safety alert (the potential hazard), and the bottom (or right-hand) panel shows the message (how to avoid the hazard).

Practicing good safety means becoming familiar with safety signs and warnings and being aware of the situations that require alertness.

Think SAFETY! Work SAFELY!

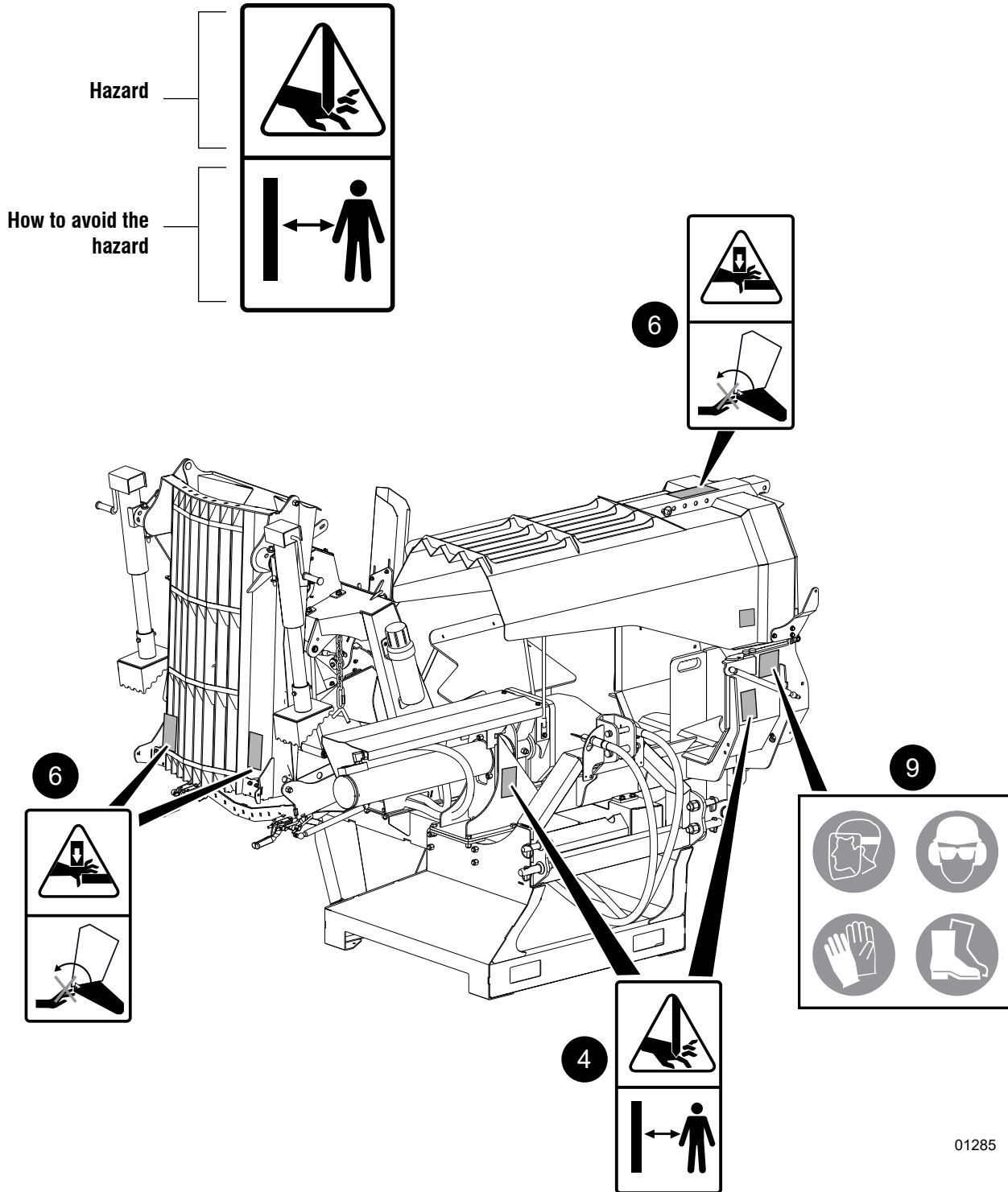

01285

Fig. 3 – Safety Sign Locations

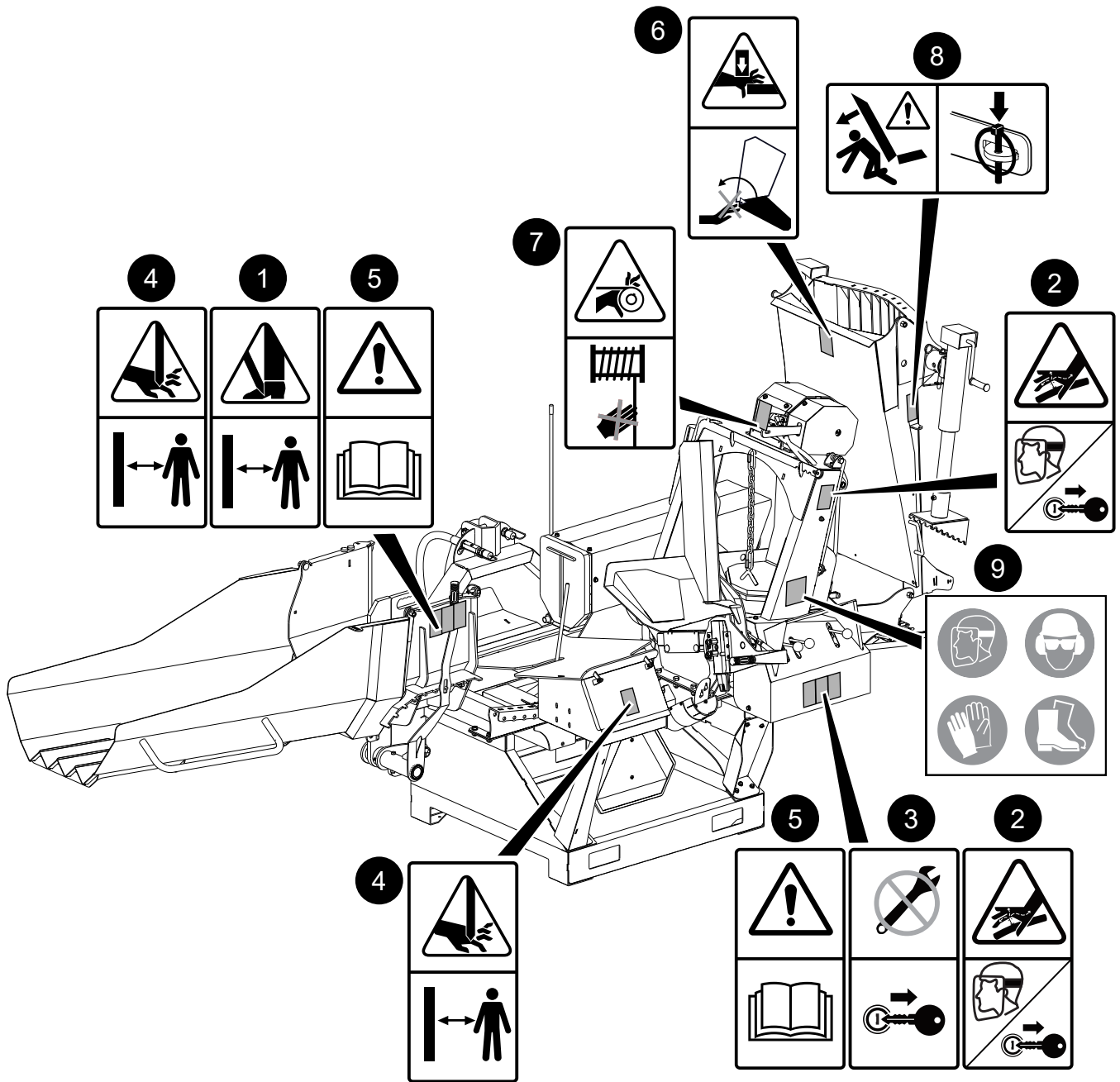

01286

Fig. 4–Safety Sign Locations

1. Warning!

Falling objects hazard in this area.
Keep feet away from falling split wood.

Always wear steel toed foot wear while machine is operating to avoid serious personal injury.

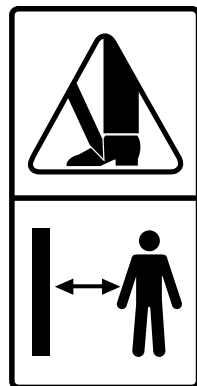

2. Warning!

Hydraulic fluid under pressure in this area. Do not check for leaks with your hand or fingers when the system is pressurized. Serious injury could result.

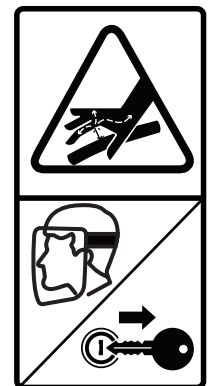

3. Warning!

Risk of serious injury or death if the engine is not shut off during maintenance procedures.

Shut off the engine and remove the key.

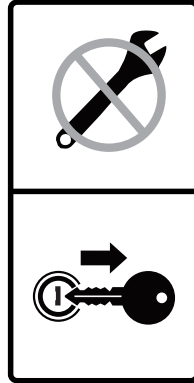

6. Caution!

Pinch point hazard. When lowering or raising the chute into position, be aware of pinch points.

Keep hands clear to avoid injury.

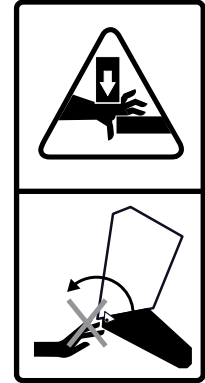

4. Warning!

Risk of hands being crushed in this area.

Keep hands clear of all moving parts.



7. Caution!

Winch entanglement hazard. When using the winch, keep hands clear of the winch rope to avoid injury.

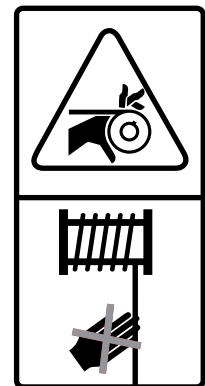

5. Caution!

Refer to the operator's manual. Read ALL operating instructions in the manual and learn the meaning of ALL safety signs on the machine.

The best safety feature is an informed operator.

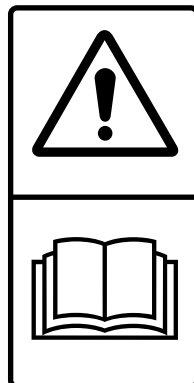

8. Caution!

Risk of machine moving unexpectedly. Make sure latch is in place during transport.

Personal injury or machine damage could result.

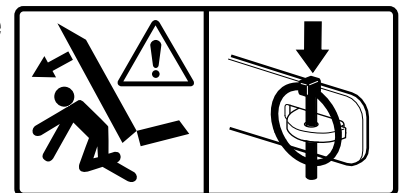

9. Warning!

Always wear appropriate Personal Protective Equipment when using this machine. For example:

- A hard hat
- Heavy gloves
- Hearing protection
- Protective shoes with slip resistant soles
- Protective glasses, goggles, or face shield

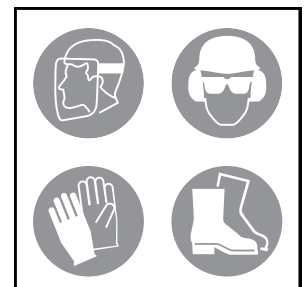

IMPORTANT! If parts are replaced that have safety signs on them, new signs must be applied. Safety signs must always be replaced if they become damaged, are removed, or become illegible.

Safety signs are included in the product decal kit available from your authorized dealer. Decals are not available separately.

2.8.1 Replacing Damaged Safety Signs

- Always keep safety signs clean and legible.
- Replace safety signs that are missing or have become illegible.
- Parts that were replaced with a safety decal on them must also have the safety sign replaced.
- Replacement safety signs are available from your authorized Distributor, Dealer Parts Department, or Wallenstein Equipment.

Procedure

1. Be sure that the installation area is clean and dry.
2. Be sure temperature is above 50 °F (10 °C).
3. Determine exact position before removing from the backing paper.
4. Pull the decal off the backing sheet, align the sign over the specified area, then carefully press the exposed sticky backing in place.
5. Use a piece of the backing paper to smooth the decal out, pressing from the center outwards.
6. Small air pockets can be pierced with a pin and smoothed out using the piece of sign backing paper.

3. Familiarization

Wallenstein Wood Processors are designed to process cut logs into split firewood. Logs are winched up the lead-in chute up to the log length guide. The customer-supplied chain saw cuts the log and the block falls in to the splitting chamber. The wedge splits the wood and pushes it out the splitter chute. Power to drive the machine is provided through the tractor hydraulic system.

If the tractor does not have hydraulic circuit connections at the rear of the tractor to power the Wood Processor, the optional Hydraulic Power Pack must be installed.

3.1 To the New Operator or Owner

It is the responsibility of the owner or operator to read this manual and to train all other operators before they start working with the machine. Follow all safety instructions. Untrained operators are not qualified to use the machine.

1. Review control location, function, and movement directions.
2. Move the unit to a large open area to allow the operator to become familiar with control function and machine response. When a new operator is familiar and comfortable with the machine, they can proceed with the work.
3. Do not allow untrained operators to use the machine. They can endanger themselves and others or damage property and the machine.

IMPORTANT! Make sure all operators understand how to put the machine in a safe service position before servicing or repairing. See page 7.

3.2 Job Site Familiarization

It is the responsibility of the operator to be thoroughly familiar with the work site prior to starting. Prevent the chance or possibility of problems or accidents by avoiding unsafe situations.

Some items operators should check include, but are not limited to:

1. Avoid close or cramped work spaces. Be sure there is enough space and clearance for the machine.
2. Position the machine so prevailing winds blow engine exhaust fumes and chain saw chips away from operator's station.
3. Choose flat and level ground and make sure the machine is level before operating.
4. Avoid muddy or soft ground.

3.3 Machine Components

The WP245 model is shown, however the 275 model has the same features.

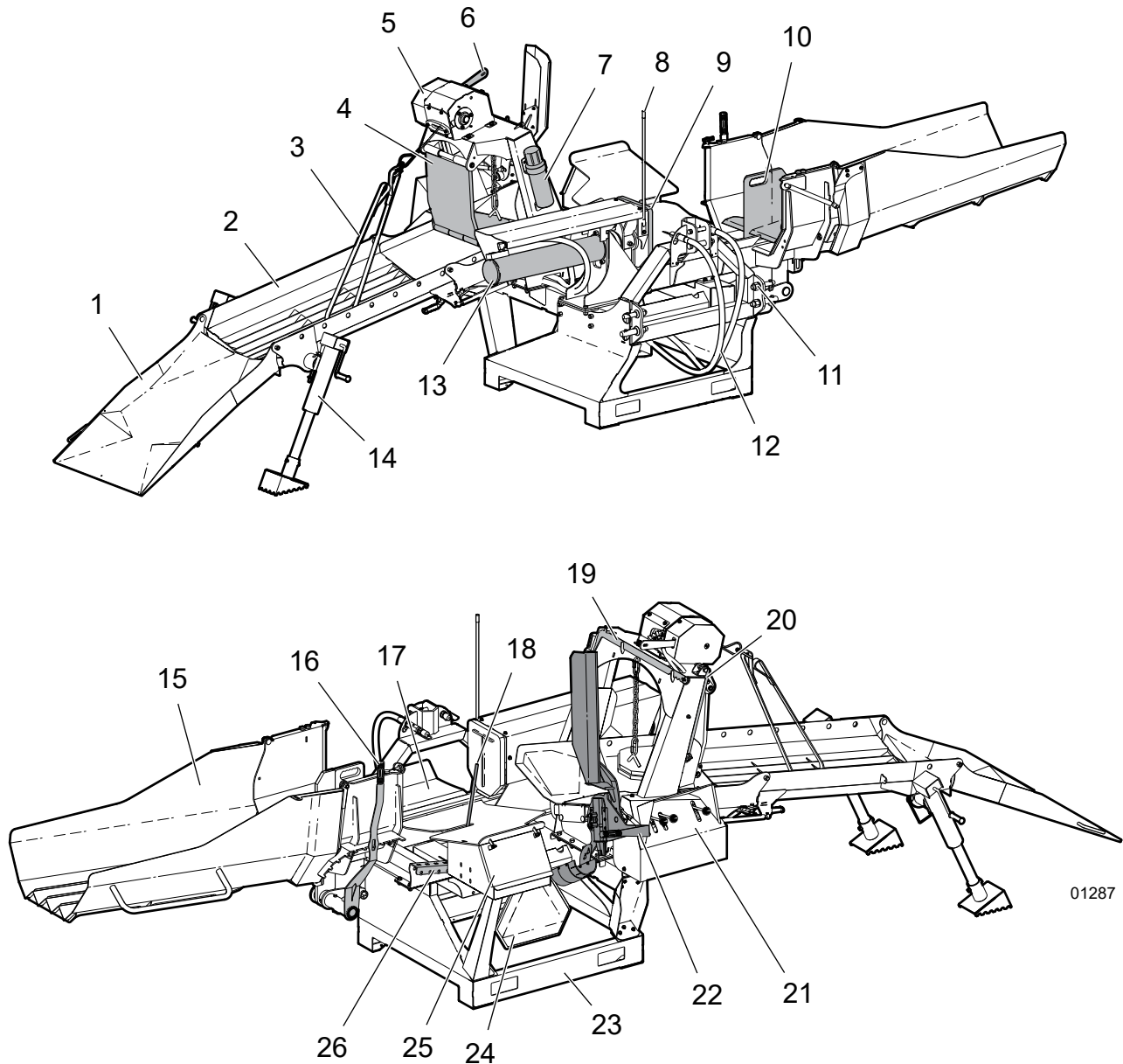

Fig. 5—Machine Components

- | | | |
|---------------------------|-------------------------------|------------------------------|
| 1. Lead-in Chute | 10. Splitting Wedge | 19. Hookaroon |
| 2. Log Loader Chute | 11. Three-point Hitch Mount | 20. Bottom Chute Latch Bar |
| 3. Winch Rope / Hook | 12. Hydraulic Hoses | 21. Operator's Control Panel |
| 4. Log Stabilizer | 13. Hydraulic Cylinder | 22. Chain Saw Holder |
| 5. Winch | 14. Bracing Jacks | 23. Three-point Hitch Base |
| 6. Winch Control Lever | 15. Splitter Chute | 24. Slow Moving Vehicle Sign |
| 7. Operator's Manual Tube | 16. Wedge Height Adjust Lever | 25. Tool Box |
| 8. Push Block Locator | 17. Splitting Cradle | 26. Log Length Guide |
| 9. Push Block | 18. Log Stop Guide | |

4. Controls

Before starting to work, all operators should familiarize themselves with the location and function of all controls.

4.1 Hydraulic Controls and Auto Cycle

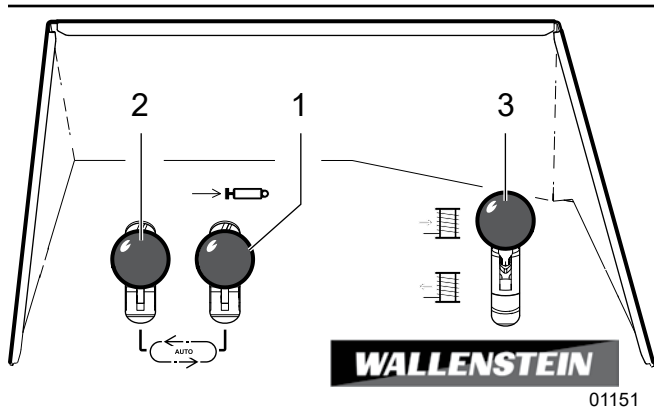

Fig. 6—Hydraulic Controls

1. Splitter Cylinder Extend
2. Splitter Cylinder Retract
3. Hydraulic Winch Control

Hydraulic Controls

Lever 1—controls the cylinder extend (the first half of the cylinder Auto Cycle).

- Push down into detent to extend the cylinder.
- When the cylinder has fully extended, the lever kicks out to neutral and stops cylinder movement. Push up on the lever to manually retract the cylinder.

Lever 2—controls the cylinder retract (the second half of the cylinder Auto Cycle).

- Push down into detent and the cylinder retracts.
- When the cylinder has fully retracted, the lever kicks out to neutral and stops cylinder movement. Lever 2 has no function in the upper position.

Auto Cycle

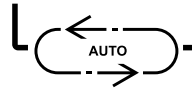

Push both levers down into the detent position to initiate the splitting Auto Cycle.

The splitter cylinder extends to split the log. When the cylinder is at the end of its stroke, Lever 1 kicks out detent. The cylinder then begins to retract. When fully retracted, Lever 2 kicks out of detent and the cylinder stops.

Hydraulic Winch Control

The far right-hand valve lever is for the Hydraulic Winch Control.

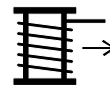

Pull the lever up to unwind the rope under power. Release the lever to stop.

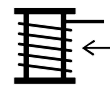

Push down and hold the lever to wind in the winch rope.

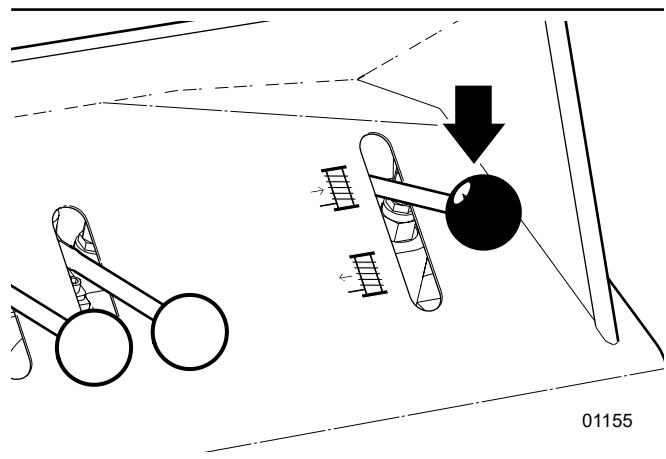
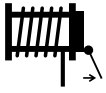

Fig. 7—Winch Control Lever

4.2 Winch Gear Lever

The Winch Gear Lever controls the winch drive system.



- Pull the lever back (towards the operator) to engage the winch drive.



- Push the lever forward to disengage the winch drive, allowing it to free wheel so rope can be pulled out and attached to a log.

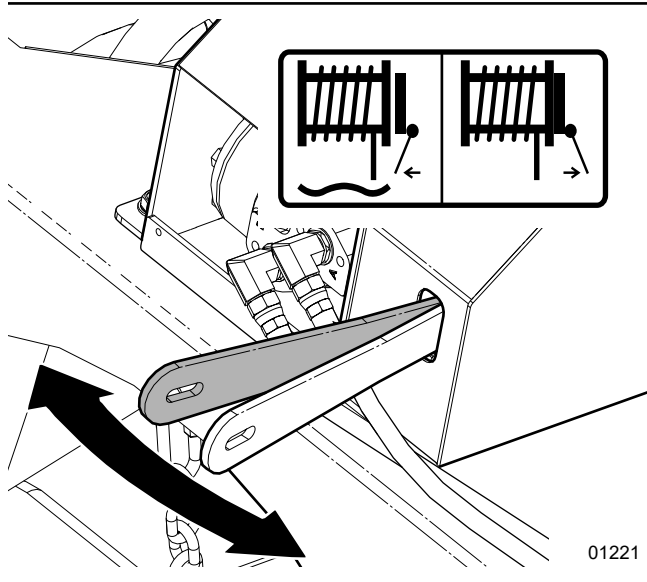
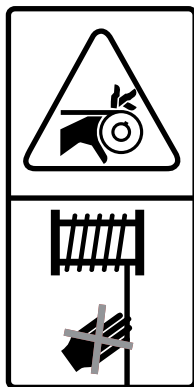

Fig. 8 – Winch Gear Lever

CAUTION!

Stay clear of the winch rope while winching. Injury from entanglement or rope burn could occur!

W056



4.3 Splitting Wedge Height Lever

Adjust Splitting Wedge height based on the size of your logs.

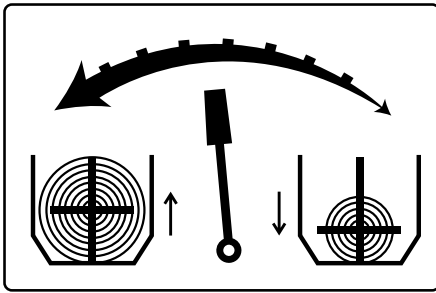

- For even-sized splits, align the center wedge with the center of the log for four-way splits up to 22" (56 cm).
- For smaller logs, fully lower the wedge for a two-way split.

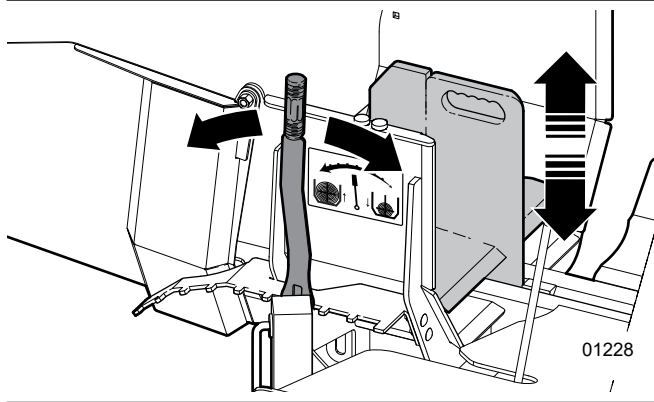

Fig. 9—Adjusting Wedge Height

A six-way wedge is available as an option.

4.4 Adjustable Log Stop Guide

Position the spring-hinged Log Stop Length Guide for desired firewood length and consistent saw cuts. The indicator can be set for log cuts from 14–24 inches with each hole 2 inches (5 cm) apart. Cut lengths are indicated on the top side of the guide.

1. Remove the snapper pin from the guide base
2. Move the guide to the desired length and replace the snapper pin.
3. Advance the log up the chute so the end of the log contacts the spring-loaded guide rod.

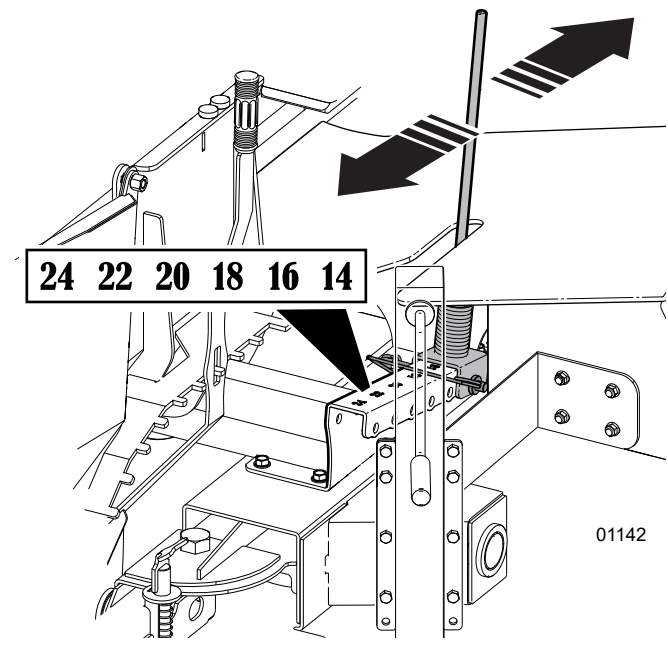

Fig. 10—Log Stop Guide

4.5 Splitter Chute Height Adjuster

To adjust the splitter chute height:

1. Lift the splitter chute up slightly to take the load off the adjuster.
2. Remove the latch pin that secures hitch pin.
3. Pull out the hitch pin that holds the adjuster in place.
4. Raise the splitter chute to the required height, line up the hitch pin holes, and replace the hitch pin.
5. Secure the hitch pin with the latch pin.

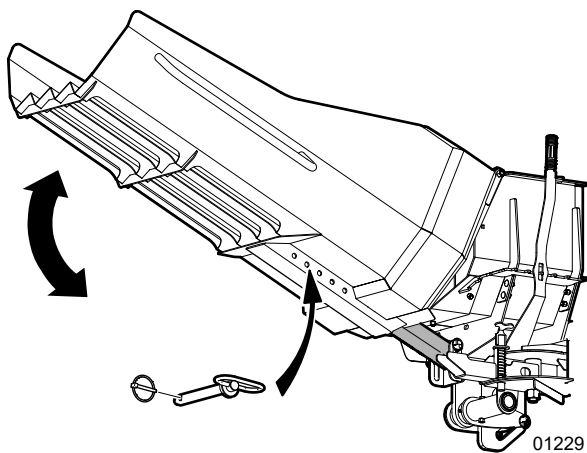

Fig. 11 – Adjusting Splitter Chute Height

5. Attaching / Unhooking

The Wood Processor should always be parked on a level, dry area that is free of debris and other foreign objects. When attaching the machine to a tractor, follow this procedure:

1. Clear the area of bystanders. Make sure there is enough room and clearance to safely back up to the machine.
2. Back up slowly and align the lower link arms to the mounting brackets on the machine.
3. Be sure the drawbar dimension is at the short length for the tractor being used. Refer to the tractor manual for adjustment procedures, or the drawbar can be removed.
4. Stop tractor, set park brake.

IMPORTANT! It may be necessary to add weight to the lower lift arms to bring them to the required height.

5.1 Mounting

1. Remove the lock pins from the side arms to allow the lower lift arms to be in their fully 'sway' configuration.
2. Align the lower link with the left-hand mounting bracket.
3. Insert the left-hand pin through the ball and install the retainer.
4. Align the right-hand arm to the pin by turning the jackscrew on the arm.
5. Insert the right-hand pin through the ball and install the retainer. Return the jackscrew to its starting position.



Fig. 12—Aligning



Fig. 13—Sway anchor pin (typical)



Fig. 14—Aligned – left side



Fig. 15—Pinned – right side

5.2 Connecting Tractor Hydraulic Circuit

1. Use a clean cloth or paper towel to clean any dirt and build-up from around the couplers.
2. Connect the hoses to the tractor rear hydraulic circuit. Be sure the couplers are securely seated.
3. Route and secure hoses along the hitch with clips or plastic ties to prevent binding and pinching.
4. Remove the top pin and install the top link. Use the turnbuckle to align the top link. Insert the pins and install the retainers. Return the turnbuckle to its original length and lock.
5. Slowly raise the machine through its working range to make sure the hydraulic components and linkages don't bottom out.
6. Level the machine front and rear, and side to side using the jackscrew on the right arm and the turnbuckle on the top link.
7. To unhook from the tractor, reverse the above procedure. Always park the machine in a dry, level area.

WARNING!

Hydraulic oil under pressure can penetrate the skin or eyes causing serious injury.

- Tighten all connections before applying pressure.
- Search for leaks with a piece of cardboard or wood, not your hand. Take care to protect hands and body from high-pressure fluids. Wear a face shield or goggles for eye protection.
- If an accident occurs, see a doctor familiar with this type of injury immediately.

W040



Fig. 16—First hydraulic circuit



Fig. 17—Second hydraulic circuit



Fig. 18—Top link



Fig. 19—Leveling adjustments

5.3 Optional Power Pack, Connecting

In the event your tractor does not have hydraulic connections at the rear of the tractor, the Hydraulic Power Pack must be installed.

Tractors equipped with the optional power pack follow this procedure:

Connect the Hydraulic System

1. Align the splines and slide the gear box on the tractor PTO shaft.

 **NOTE:** Make sure the PTO shaft is clean and free of dirt.

2. Attach the anchor chain to an adjacent frame member to prevent the gear box from turning and to hold the assembly on the shaft.
3. Route and secure hoses along the hitch with clips or plastic ties to prevent binding and pinching.
4. Remove the top pin and install the top link. Use the turnbuckle to align the top link. Insert the pins and install the retainers. Return the turnbuckle to its original length and lock.
5. Slowly raise the machine through its working range to make sure the hydraulic components and linkages don't bottom out.
6. Level the machine front and rear, and side to side using the jackscrew on the right arm and the turnbuckle on the top link.
7. To unhook from the tractor, reverse the above procedure. Always park the machine in a dry, level area.

WARNING!

Hydraulic oil under pressure can penetrate the skin or eyes causing serious injury.

- Tighten all connections before applying pressure.
- Search for leaks with a piece of cardboard or wood, not your hand. Take care to protect hands and body from high-pressure fluids. Wear a face shield or goggles for eye protection.
- If an accident occurs, see a doctor familiar with this type of injury immediately.

W040



Fig. 20 – Gear box



Fig. 21 – Anchor chain



6. Operating Instructions

6.1 Operating Safety

- Review Safety Rules on *page 7*.
- Keep bystanders away at a safe distance at least 20 ft (6 m) from stacking zone. Mark the zone with safety cones.
- De-limb logs and pre-cut to length.
- Operate the machine in daylight or good artificial light only.
- Make sure machine is properly stationed, adjusted and in good operating condition.
- Perform the Pre-operation Checks before starting work.
- Do not operate on hillsides or when working area is cluttered, wet, muddy, or icy to prevent slipping and tripping. Keep working area clean and free of debris.
- Stop engine if leaving the machine unattended.
- Make sure all guards, deflectors and shields are installed before starting and operating the machine.
- Operate the machine only when physically fit and not under the influence of alcohol, drugs or medicines that can cause drowsiness.
- Avoid loose fitting clothing, uncovered long hair, jewelry, and loose personal articles. These can get caught in moving parts.
- Do not allow anyone within the work or hazard zones during operation.
- Do not try to process more than one log at a time. The extra log can move unexpectedly and cause injury.
- Use a peavey or the provided hookaroon if repositioning cut logs in the splitting cradle. Never reach into the splitting area with your hands when the machine is operating.
- Do not try to split logs across the grain. Some logs can burst or splinter and fly out of the machine causing injury.
- Use care when pulling logs from a pile for splitting as they can roll when attaching rope or winching toward wood processor. Handle logs using a peavey for positioning.
- Keep working area clean and free of debris to prevent tripping.
- Read the chain saw operator's manual and follow all safety instructions.

6.2 Pre-Operation Checks

1. Review the Operating Safety (see *page 7*).
2. Review the Machine Controls (see *page 18*).
3. Clear the area of bystanders.
4. Review Machine Set-up (see *page 26*).
5. Check the following areas each time the machine is operated. It is important for both personal safety and good maintenance practices that a walk around check is performed before operating the Wood Processor.

Area to Check	
Check and lubricate the machine per the schedule outlined in the Maintenance Section.	
Check the condition of the choker strap. Replace if torn or worn out.	
Check for entangled material. Remove any twine, wire or other material that has become entangled.	
Check the condition of the winch rope. Replace cut, knotted, worn or if it has any broken strands. Replace rope if damaged.	
Check the wedge and block. Inspect for damaged or broken components and excessive wear. Lubricate, repair, or replace as required.	
Check and ensure that all covers, guards, and shields are in place, secured and functioning as designed.	
Check all fasteners and tighten, and ensure your equipment is working and in good repair.	
Check for hydraulic leaks. Tighten fittings or replace components to stop leaks.	
Check hydraulic oil level. Top up as required.	
Check the condition of the winch. It must be in good condition to operate properly.	
Check that personal protection equipment including hard hat, safety glasses, safety shoes, safety vest, hearing protection, and gloves are being used and in good repair.	
Check that all loose-fitting clothing or jewelry is not worn, and loose long hair is tied back.	

6.3 Machine Set-Up

Follow the steps on the next pages to set-up the machine at the work site:

! WARNING!

Engine exhaust contains carbon monoxide, an odorless, poisonous gas. Breathing it can cause unconsciousness or death.

Never operate engine in a closed, or even partly closed area. Exhaust gases can build up to dangerous levels.

W072

1. Use the tractor to position the machine and set it down at the work site.
2. Remove the snapper pins securing the bracing jacks and turn them up to the bracing position.
3. Replace the snapper pins to secure the jacks.

NOTE: *Angle the jacks upward so they will contact the ground evenly when the chute is lowered.*

4. Remove the latch pin that holds the chute lock arm to the log loader chute.
5. Pull the lock arm away from the chute and swing it down. Secure it to the side of the frame with the latch pin.

Steps 6–14 are shown on the next page.

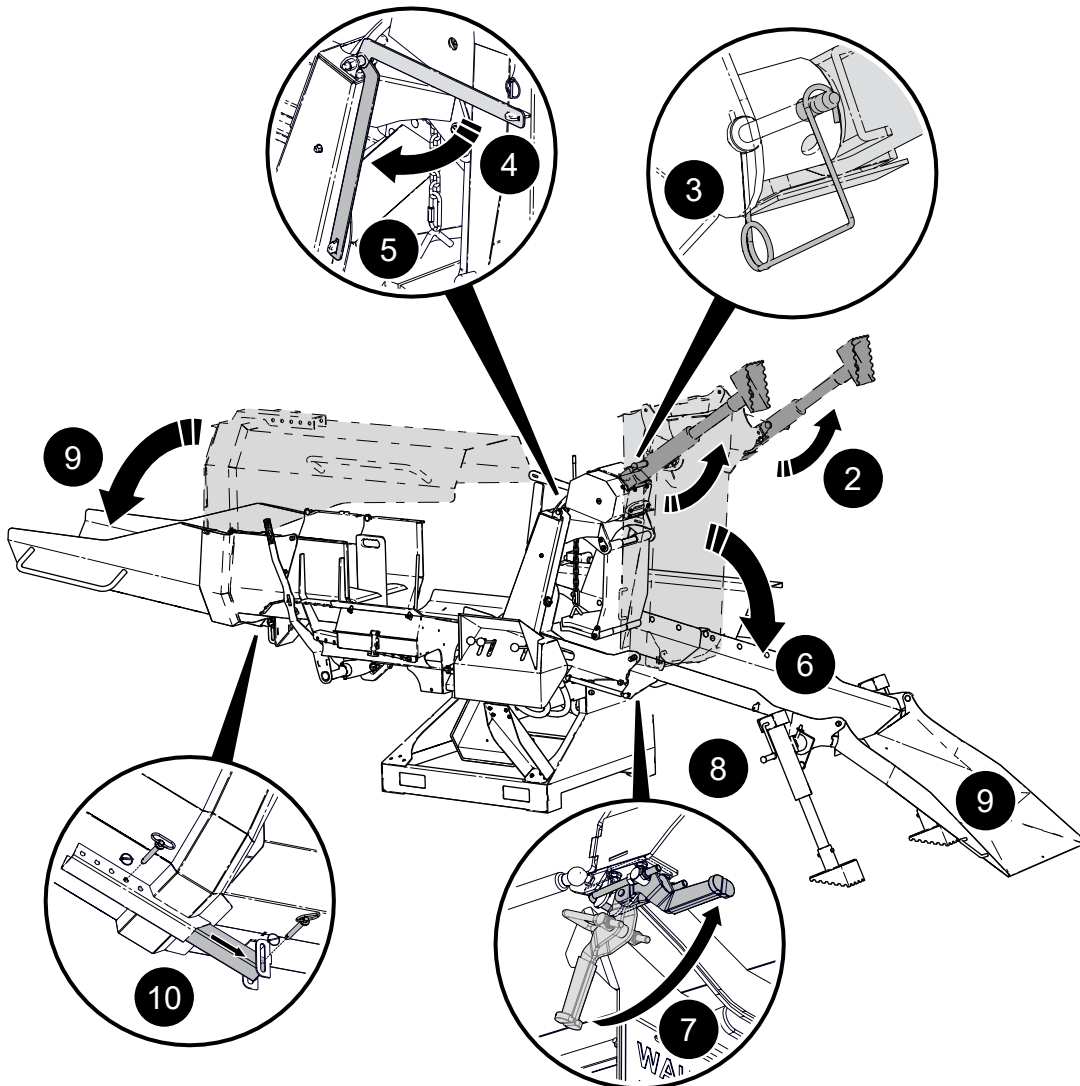

Fig. 23– Machine Set Up

6. Carefully fold the log loader chute down.
7. Under the chute, hook the latch over the latch catch. Snap the handle of the latch clamp into lock position. There is one on each side.
8. Crank the bracing jacks until the jack feet are firmly into the ground.
9. Carefully unfold the splitter chute.
10. Adjust the splitter chute to the required height, using the chute lock arm and placing the hitch pins in the appropriate hole position.
11. Unclip the winch hook from the log stabilizer chain.
12. Check that the log stabilizer chain allows the stabilizer to move freely and not hinder the log.
13. Finally, adjust the splitter chute to the required height, crank the bracing jacks so they are firmly on the ground, but ensure the front lip of the lead in chute is on the ground (to avoid catching on logs). If required, adjust the 3-point hitch so the lead in chute is level with the ground and the bracing jacks have a firm grip.
14. Move the wagon, trailer, or conveyor into position under the discharge chute.

The wood processor is now ready to work.

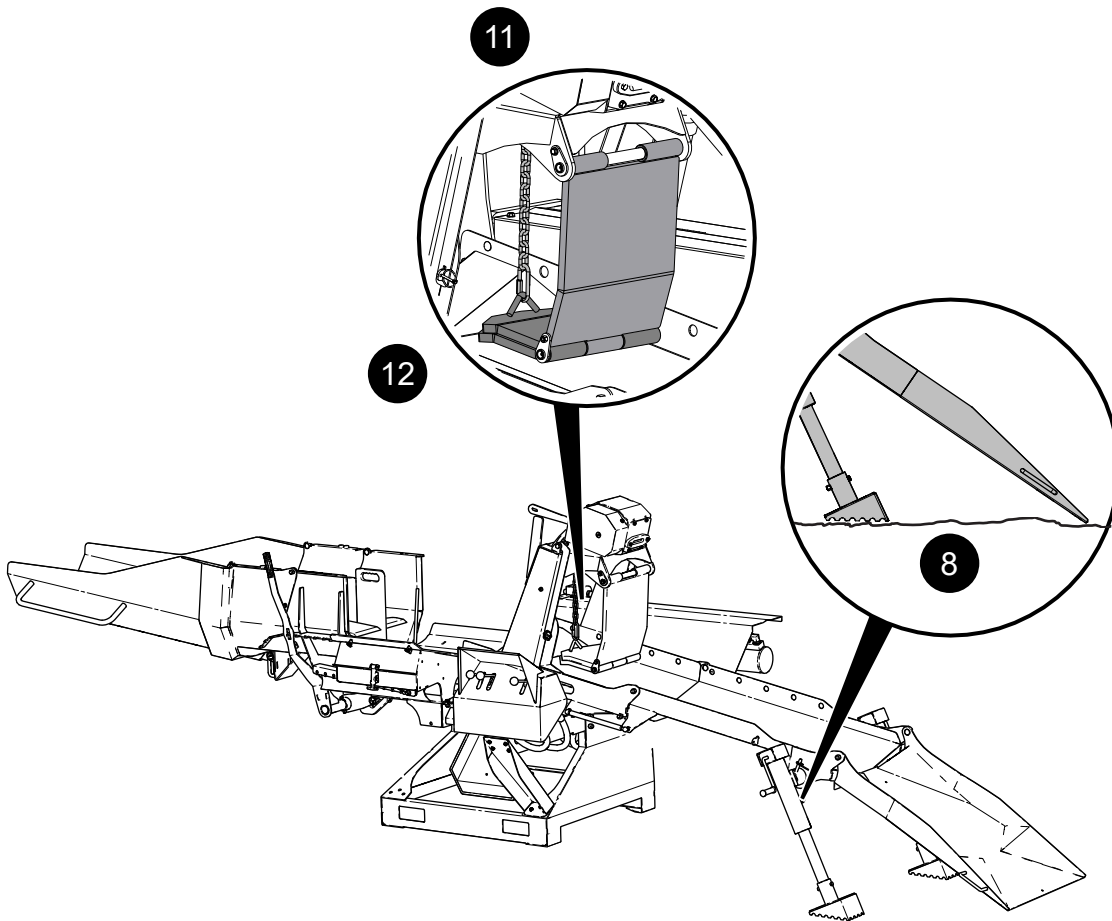

Fig. 24– Machine Set Up

6.4 Attaching Chain Saw to Holder

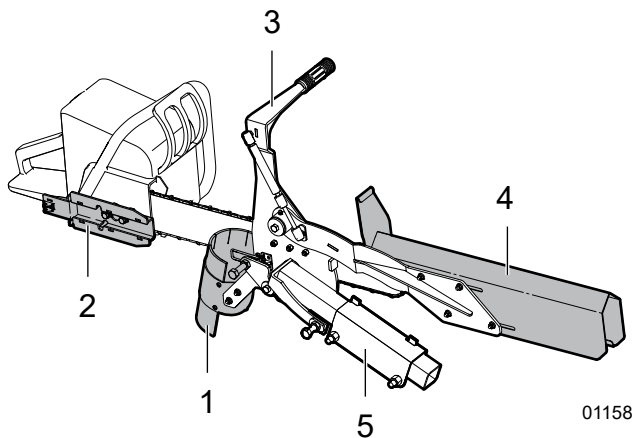

Fig. 25—Pivoting Chain Saw Holder

1. Debris Chute
2. Universal Chain Saw Adapter Plate
3. Pivot Handle
4. Chain Saw Guard
5. Pivot Base

CAUTION!

Review your chain saw manual for safe operating and handling procedures before beginning work.

WARNING!

Do not attach a chain saw to the holder with a bar length longer than 30" (75 cm). The cutting chain could contact the push block or cylinder rod causing a hazardous situation. Injury or machine damage could result from flying debris.

IMPORTANT! The chain saw must have dual bar-mounting studs to mount the chain saw adapter plate. Saws with captive guide bar nuts require them to be removed.

1. Remove the chain sprocket cover nuts from your chain saw. Some chain saws feature captive guide bar nuts in the chain sprocket cover. On these saws, replace the guide bar nuts with bushing spacers (2).
2. Thread the two bar mounting studs (3) onto the guide bar studs on your saw.
3. Install the universal chain saw adapter plate (1) over the bar mounting studs.

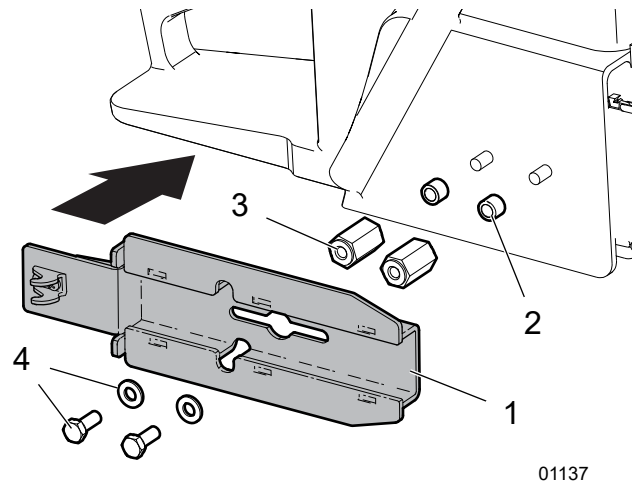

Fig. 26—Universal Chain Saw Adapter Install

1. Universal chain Saw Adapter
 2. Bushing Spacers
 3. Bar Mounting Studs
 4. Hex Bolts and Washers
4. Fasten everything together with the M8 x 20 mm hex bolts (4) and washers.
 5. Slide the saw adapter plate into the guides on the chain saw pivot. Make sure the draw latch is open so the saw can slide in without interference.

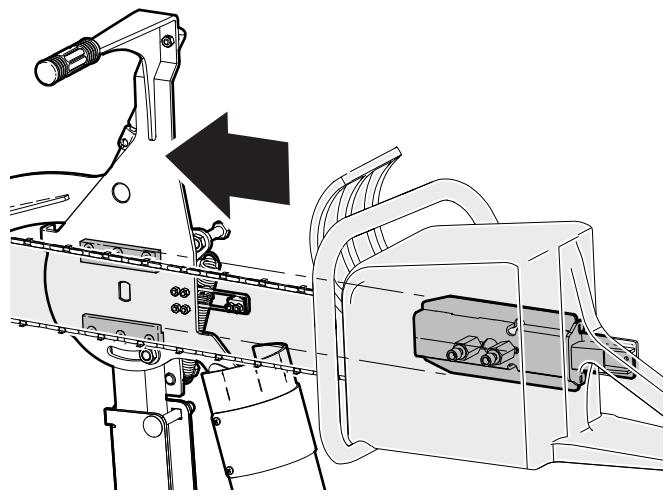



Fig. 27—Chain Saw Pivot

6. Close the draw latch over the catch on the saw / adapter plate. This tightens the saw to the pivot assembly.
7. Check the range of motion of the saw. Make sure the bar cannot contact any part of the machine. Pull the saw off and adjust the adapter plate position as required.

 **NOTE:** Some adjustment may be required to the pivot base, depending on the saw length.

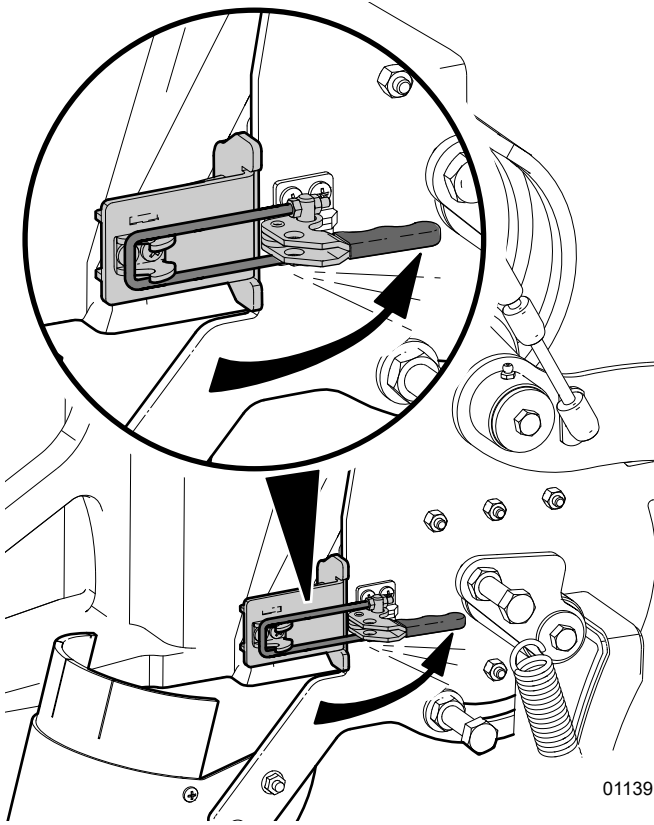

Fig. 28—Draw Latch on Chain Saw Pivot Frame

6.5 Setting Log Stop Guide

Cut length is indicated in inches on the top of the slide.

- Pull out the snap lock pin to reposition the indicator.
- Set it at any desired position along the slide.
- Advance the log up to the stop for each cut.

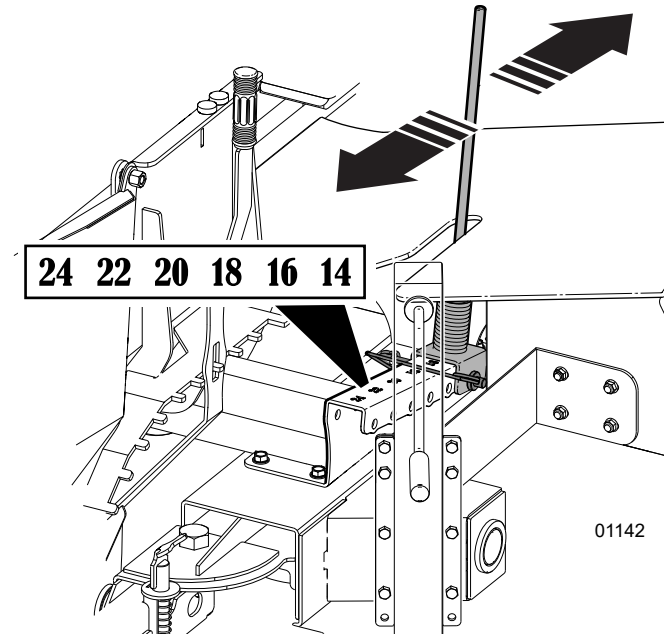

Fig. 29—Log Stop Guide

6.6 Starting

1. Make sure all controls are in neutral or off.
2. Start tractor engine and allow it to warm for a few minutes.
3. Engage hydraulic circuit.
4. Increase throttle setting to maximum speed for operation.
5. Move to the operator's station on the wood processor to begin work.

6.7 Stopping

1. Stop all work operations.
2. Move hydraulic controls powering the wood processor to neutral or off.
3. Slow tractor engine speed to idle. Allow the engine to operate for a few minutes to cool down.
4. Turn off tractor engine.

6.8 Emergency Stopping

If an emergency occurs:

1. **Shut off the engine.**
2. **Set all hydraulic controls to neutral.**

Correct emergency situation before restarting engine and resuming work.

6.9 Winching

CAUTION!

Always make sure the area is clear of bystanders when operating the winch. Never use the winch to hold or secure loads.

W055

CAUTION!

Stay clear of the winch rope while winching. Injury from entanglement or rope burn could occur!

W056

- Never stand directly in line with the winch rope while winching. Do not touch winch rope during operation.
- Check rope condition before using winch. Rope may break during operation if it is cut, knotted, has broken strands, or worn. Replace rope if damaged.
- Do not winch down a slope; always winch up a slope. Winching down a slope could cause the log to roll resulting in crushing injuries.
- Do not operate on hillsides or when working area is cluttered, wet, muddy, or icy to prevent slipping and tripping.

- Do not winch across a slope. Always winch up-slope.
- Do not allow anyone not directly involved with winching within 10 ft (3 m) of winch or logs during winching operation. Keep children away. Logs could roll in unpredictable ways.
- Always wind in the rope under load. Rope does not wind in properly if not under load.
- Do not touch or grasp the rope during winching operation.
- Always use the winching strap or a choker chain to attach to the log for winching. The winching rope can be damaged if dragged under the log if a choker or strap is not used.
- Always be aware of hazards when winching and moving logs. Inspect your work zone to take these hazards into account:
 - objects along winch route
 - structures close or in the work zone
 - winching on a slope

IMPORTANT! The Wood Processor winch is designed to use synthetic rope. Use synthetic rope as replacement only. Using anything else creates an unsafe work environment and voids warranty.

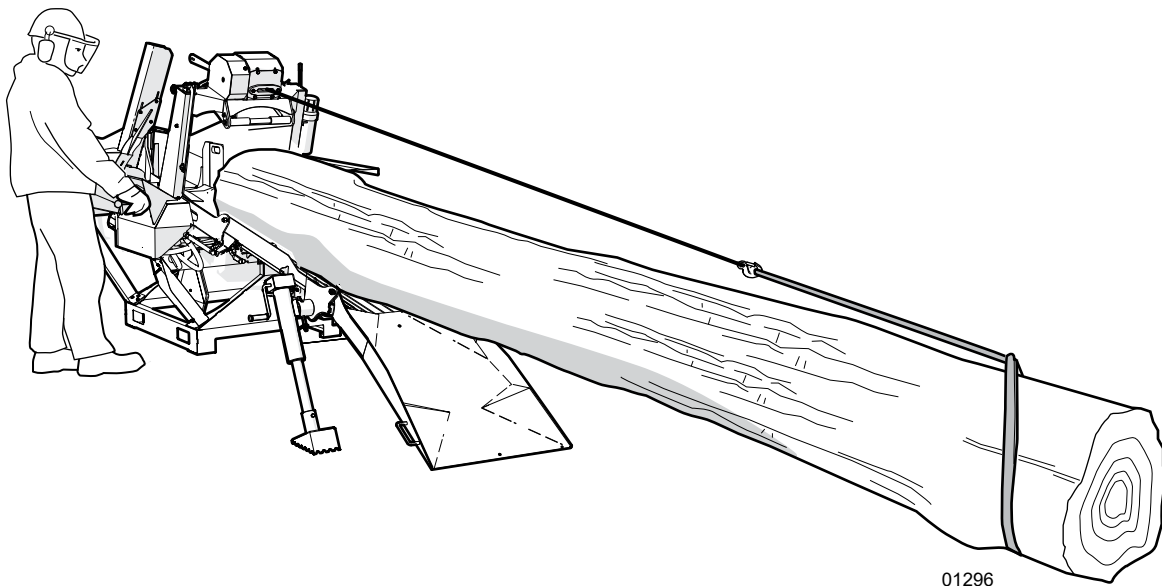

01296

Fig. 35—Winching a Log

1. Release the winch rope by pushing the winch drive lever away from you.

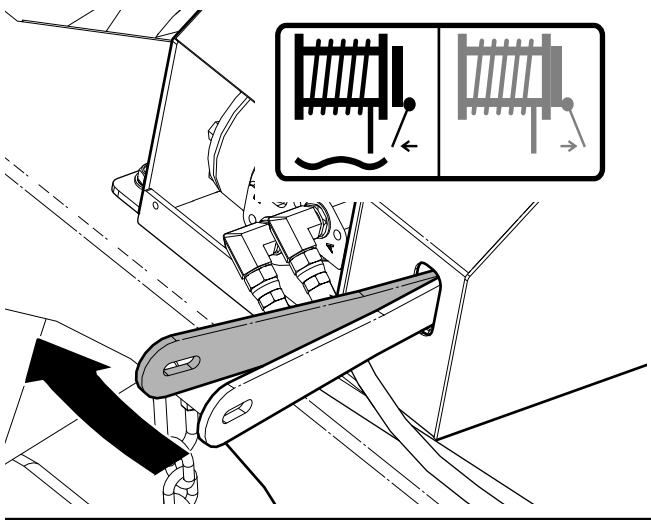

Fig. 30 – Winch Drive Lever

3. Attach the 60" (1.5 m) winch strap to the log, then attach the winch rope to the strap. Do not attach the winch rope directly to the log. (A standard log chain can also be used.)

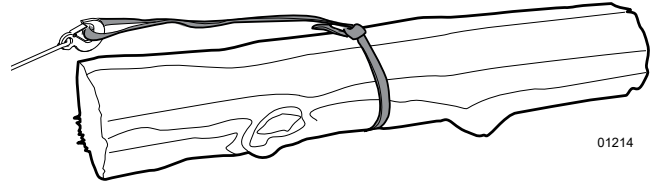

Fig. 31 – Winch Strap

4. Pull the winch gear lever back towards you to engage the winch drive.

2. Grasp the hook on the winch rope and pull the rope out to the log.

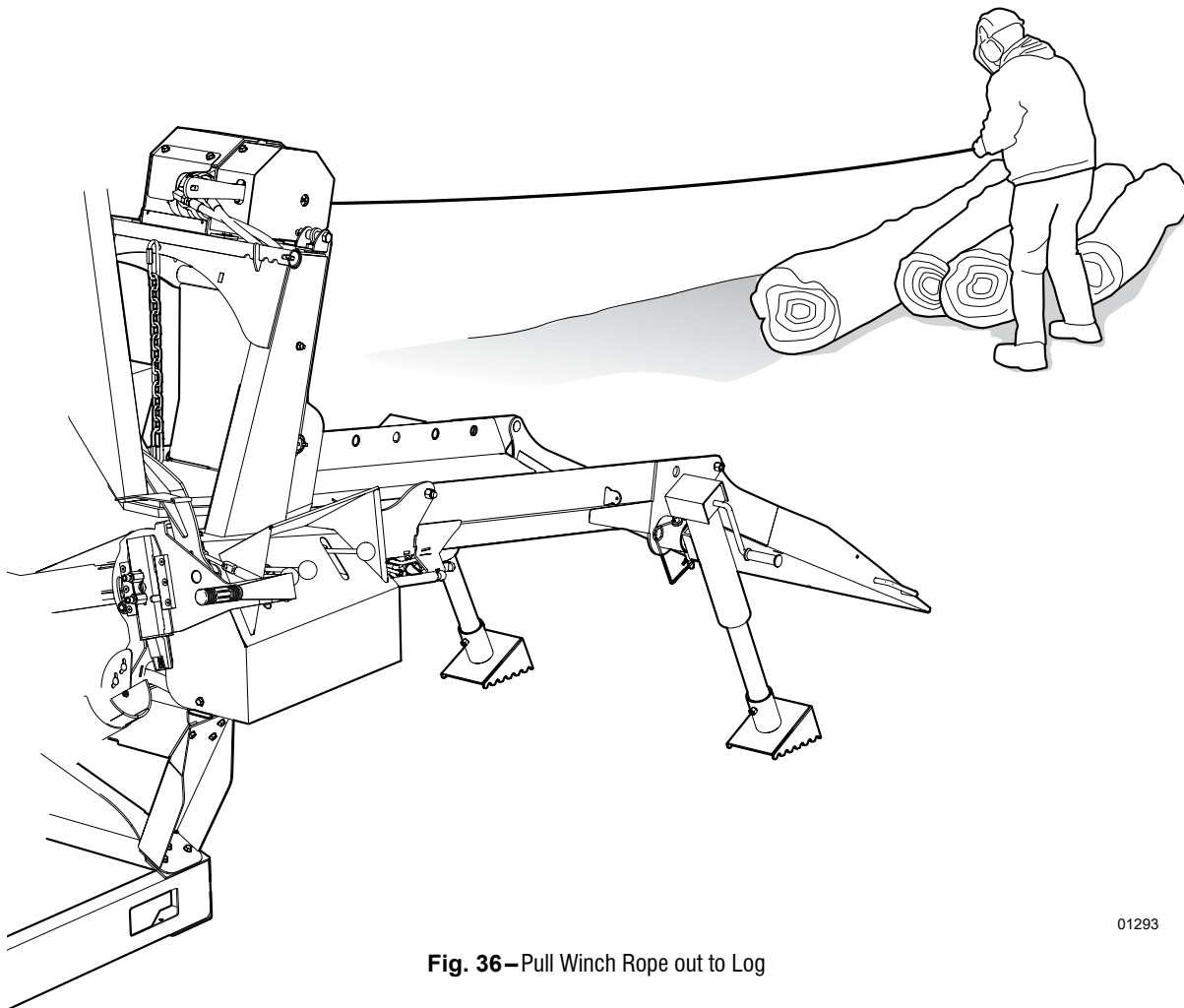

Fig. 36 – Pull Winch Rope out to Log

- Winch the log into log lead-in chute. Be careful the log does not catch on the front lip of the chute.

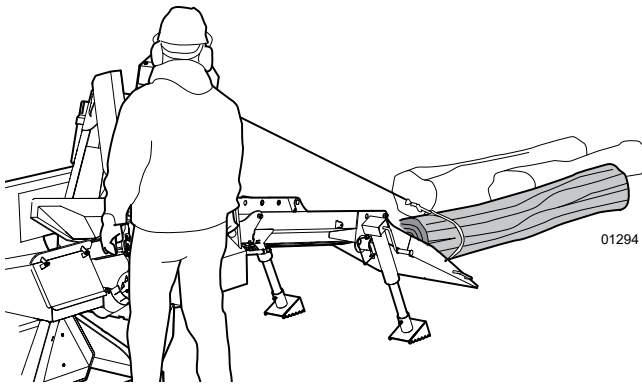

Fig. 32—Winching up First Log

- Continue to winch up to the log stabilizer.

IMPORTANT! Stop winching when the hook reaches the winch. If the operator is winching and the log is not moving, it is most likely because the winch is fully retracted. Continuing could pull the hook off the end of the rope.

- Make sure the log is stable, then disengage the winch gear.
- Move the strap to the far end of the log.
- Pull out the winch rope and re-attach the winch hook.

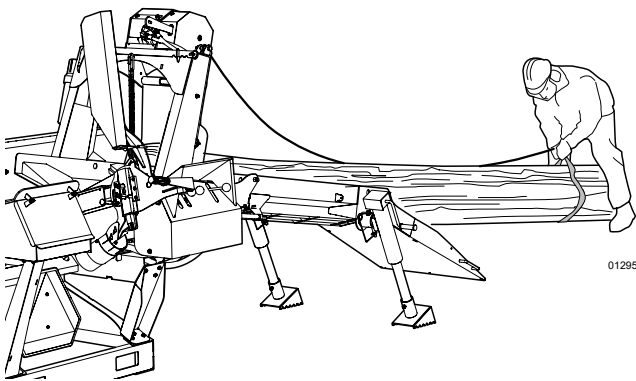

Fig. 33—Reposition Winch Strap to End of Log

- Engage the winch and pull the log through the log stabilizer up to the Log Stop Guide.

! WARNING!

Log Stabilizer is heavy! Never attempt to push a log by hand through the stabilizer opening. The stabilizer could drop suddenly and cause serious injury. Always use appropriate procedure and tools to push or pull the log through the opening.

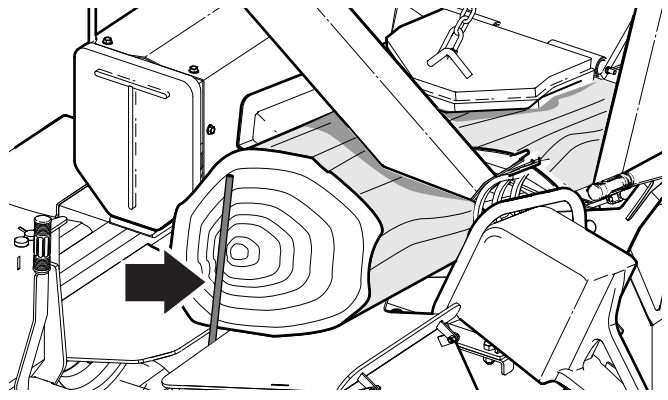

Fig. 34—Winch up to Log Stop Guide

6.10 Cutting

WARNING!

Review the chain saw operator's manual and follow all safety instructions.

Always wear appropriate Personal Protective Equipment when using a chain saw.

CAUTION!

Always apply the chain saw brake when leaving the saw idling.

Make sure your chain saw is sharpened and in good working order.

Have the Log Stop Guide set to the desired cut length with the log winched up to it.

1. Operate the saw as you normally would to cut a log. You can also push on the chain saw holder handle. The guard stays on top of the log as the saw cuts through it.
2. Decrease cutting pressure as you finish the cut.
3. Let the cut log roll into the splitting cradle.

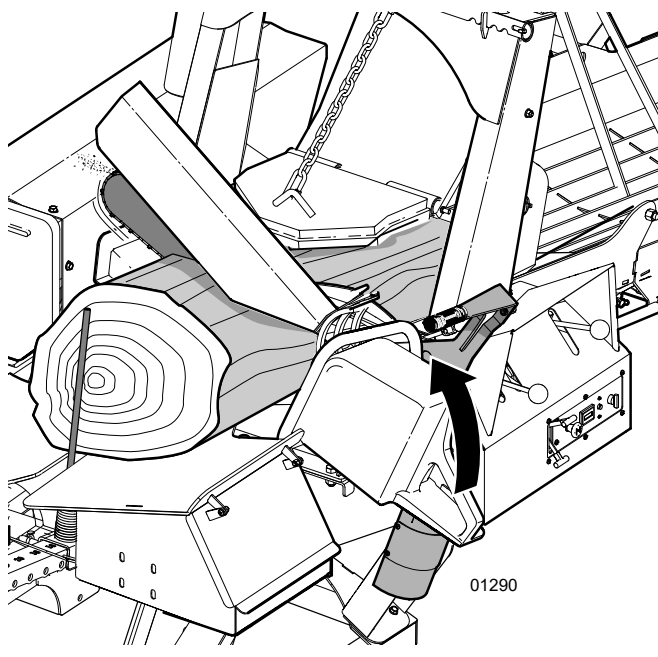

Fig. 37 – Cutting the log

6.11 Splitting

CAUTION!



Risk of pinching or crushing hazard! Never reach into the splitting cradle to reposition a log. Use a log peavey, hookaroon or another tool.

W043

After each cut, the log rolls onto the splitting cradle.

1. Using the Wedge Height Lever, set the height of the wedge according to the diameter of the log. The control lever is on the side of the splitting cradle. Raise or lower depending on log size.

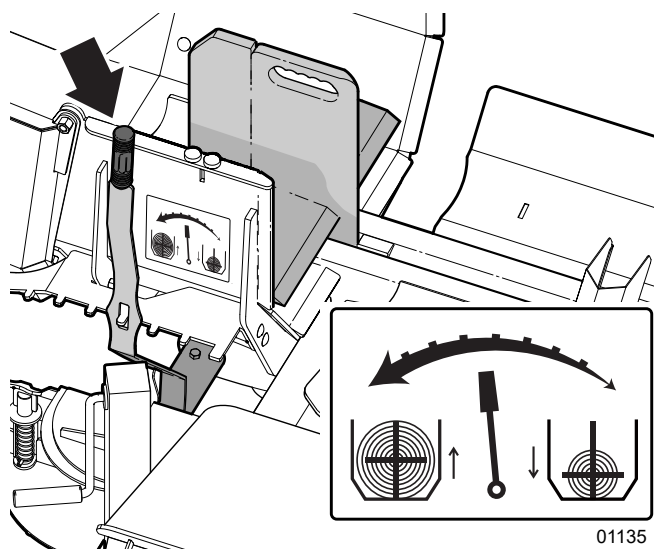

Fig. 38 – Splitting Cradle

 **NOTE:** A six-way splitting wedge is available as an accessory.

2. Push both splitter control levers down into detent to begin the Auto Cycle.

- The push block extends to split the wood, then retracts. Both control levers reset to neutral when the auto-cycle completes.

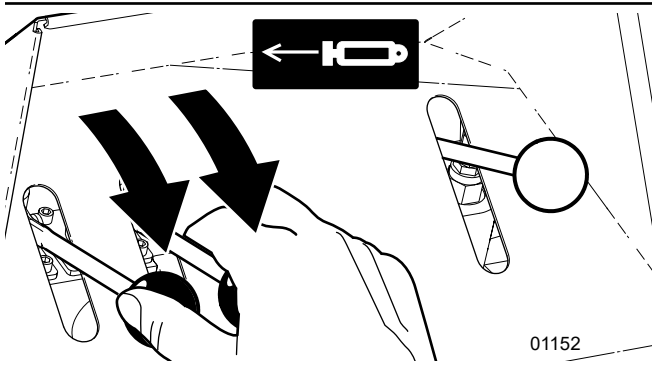

Fig. 39—Push Both Control Levers Down

- At the end of the cylinder stroke, the *extend* control lever kicks out of detent to neutral and the cylinder then retracts.

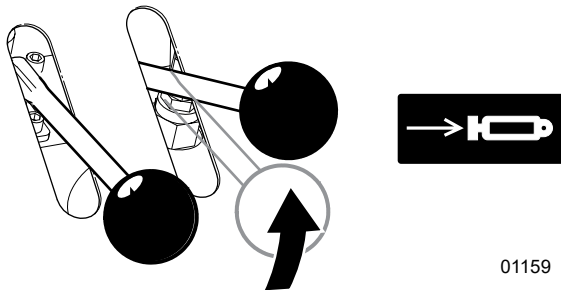

Fig. 40—Cylinder Retracts

- When the cylinder has fully retracted, the *retract* control lever kicks out to neutral and the push block is set for the next cycle.

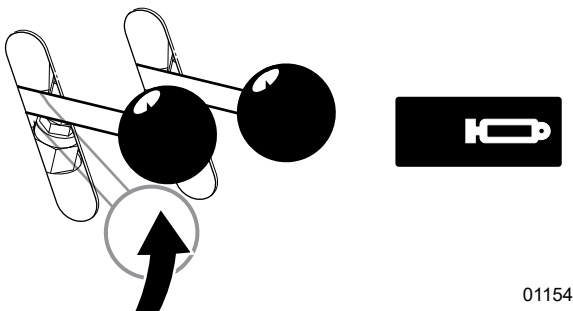

Fig. 41—Reset for the next cycle

Winch the log up to the guide again to make the next cut. Continue cutting and splitting to finish the log.

6.12 Next Log

As the first log finishes, it will be too short to winch in. At this point, winch in another log behind the first one and use it to push the first log into the cutting area.

1. Make sure the first log in the Wood Processor is stable, then release the rope and hook.
2. Pull the rope out to the second log.
3. Wrap the winch strap around log. You may need to roll the log onto the strap using a log peavey.
4. Attach the winch hook onto the winch strap.

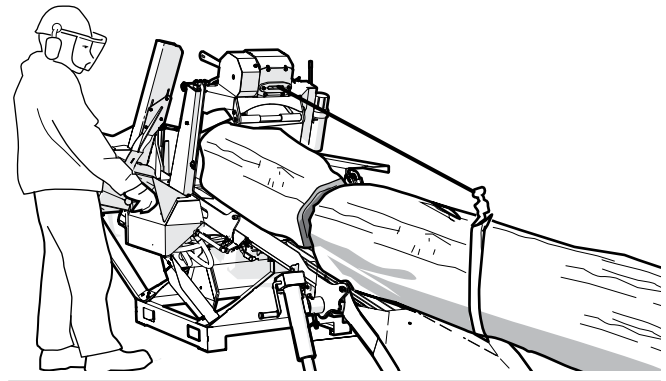

Fig. 42—Use second log to push first one

5. Engage winch drive mechanism with the winch gear lever.
6. Use the winch to pull log into log lead in chute up against the first log. Use it to push the first log up to the cutting guide.
7. After a few cuts, reposition the winch strap to the far end of the second log, and continue winching and cutting.

6.13 Last Log

As you finish the last log, you will find it is too short to winch in.

1. Move the last log up using a log peavey as a lever inserted into holes at side of chute.
2. Move the log up for each cut until it is fully processed.

Be aware of the heavy log stabilizer. Use caution when finishing up the last log.

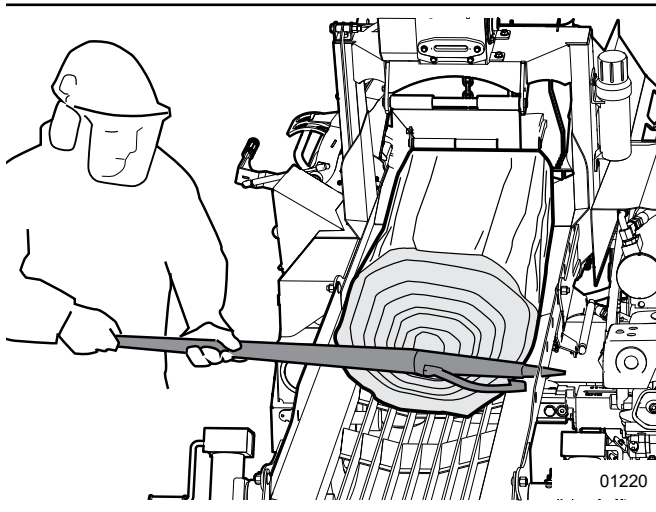

Fig. 43—Pushing last log through

CAUTION!

Risk of serious injury. Never attempt to push a log through the stabilizer opening by hand. The stabilizer could drop suddenly and cause serious injury. Always use appropriate procedure and tools to push or pull the log through the opening.

6.14 Efficient Processing

We recommend following this procedure for an effective work flow:

1. Move log into the wood processor with winch.
2. Cut log and let the block roll into the splitting cradle, then engage the splitter.
3. While the log is being split, winch the log into position for the next cut.
4. Make the next cut and let the block roll into the splitting cradle.
5. Repeat until complete.

6.15 Machine Break-In

Although there are no operational restrictions on the Wood Processor when used for the first time, it is recommended that the following mechanical items be checked:

After 1–5 hours of operation:

1. Check all nuts, bolts, and other fasteners. Tighten to their specified torque.
2. Check hydraulic system for leaks. Tighten all leaking fittings and replace any leaking components.
3. Check machine hydraulic oil reservoir. Top up as required.
4. Check condition of winch.
5. Check the condition of the rope. Replace if cut, knotted, worn or if it has any broken strands.
6. Check for entangled material. Remove all entangled material before resuming work.
7. Lubricate all grease fittings.

After 20 hours of operation:

8. Repeat steps 1 through 7 listed above.
9. Go to the normal servicing and maintenance schedule as defined in the Service and Maintenance section. See *page 39*.

6.16 Transporting

- Fold up the splitter chute, and the lead-in and loader chutes. Insert the lynch pin for the splitter chute.
- Hook up the lead in chute lock arm and install latch pin.
- Clean the machine. Dirt and debris can fall off affecting other traffic. Remove any loose tools.
- Make sure that the machine is securely attached to the tow unit with a retainer through the 3-point-hitch arms.
- Never allow riders on the machine.
- Plan your route to avoid heavy traffic.
- Comply with state and local laws governing safety and transporting of machinery on public roads.
- Do not exceed a safe travel speed. Slow down for rough terrain and cornering.

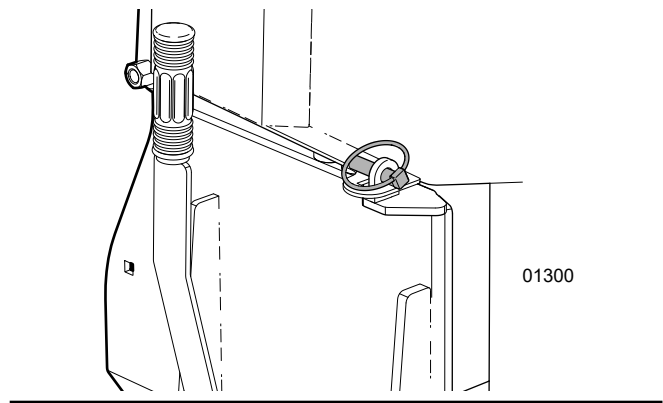

Fig. 44—Splitter Chute Lynch Pin

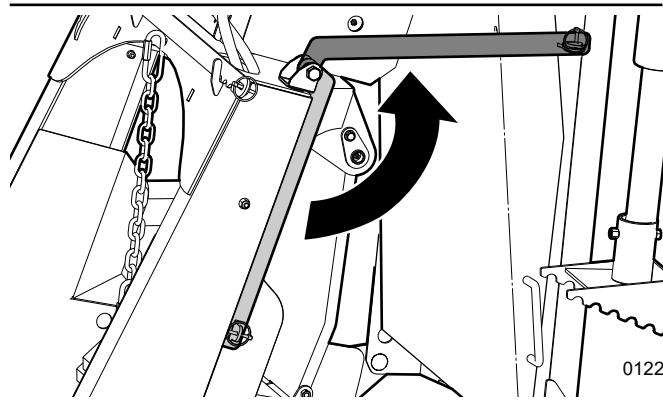

Fig. 45—Chute lock arm and latch pin

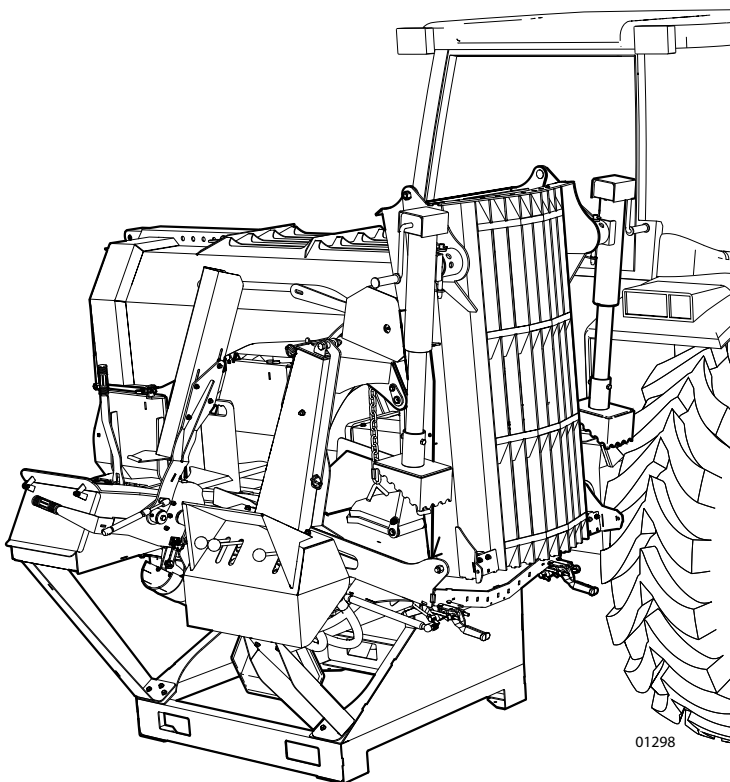

Fig. 46—WP245 ready to transport

6.17 Storage

Placing Wood Processor in Storage

After the season's use or when the machine will not be used for a period of time, place the machine in storage. Completely inspect all major systems of the Wood Processor. Replace or repair any worn or damaged components to prevent any unnecessary down time at the beginning of the next season.

1. Remove all wood from the machine.
2. Thoroughly clean the machine to remove all dirt, mud, or debris.
3. Inspect all moving parts. Remove any entangled material.
4. Check the condition of winch rope. Replace or adjust as required.
5. It is best to store the machine inside. If that is not possible, cover with a waterproof tarp.

Removing from Storage

When removing this machine from storage, the Pre-operation Checks on page 25.

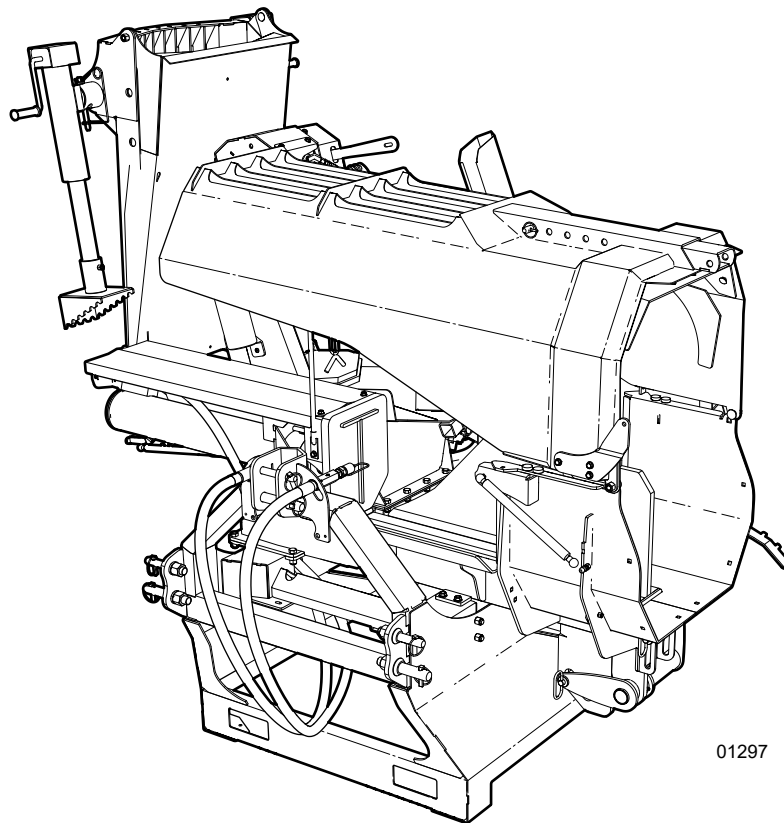

Fig. 47 – Storage Position

7. Service and Maintenance

WARNING!

Risk of serious personal injury. Stop engine before performing ANY service or maintenance procedure. Reinstall all covers and guards removed before putting machine back into service.

W033

Place the machine in a Safe Condition before performing any service, maintenance work or storage preparation by performing the following:

SAFE CONDITION

1. Clear infeed conveyor and splitting hopper.
2. Wind in winch rope.
3. Release all controls and ensure all components have stopped moving.
4. Shut off the engine.
5. Relieve hydraulic system pressure by actuating controls.
6. Make sure parking brake is applied and chock wheels to prevent movement.

- **Good maintenance is your responsibility. Poor maintenance is an invitation to trouble.**
- **Follow good shop practices.**
 - **Keep service area clean and dry.**
 - **Be sure electrical outlets and tools are properly grounded.**
 - **Use adequate light for the job at hand.**
- **Never operate the tractor engine in a closed building. The exhaust fumes may cause asphyxiation. Make sure there is plenty of ventilation.**
- **Never work under equipment unless it is blocked securely.**
- **Always use personal protection equipment such as eye, hand and hearing protection when performing any service or maintenance work. Use heavy gloves when handling sharp components.**
- **Where replacement parts are necessary for periodic maintenance and servicing, genuine factory replacement parts must be used to restore your equipment to original specifications. The manufacturer cannot be responsible for injuries or damages caused by use of unapproved parts and/or accessories.**

- **A fire extinguisher and first aid kit should be kept readily accessible while performing maintenance on this equipment.**
- **Periodically tighten all bolts, nuts and screws and check that all electrical and fuel connections are properly secured to ensure unit is in a safe condition.**
- **When completing a maintenance or service procedure, make sure all safety shields and devices are replaced before returning machine to service.**

7.1 Fluids and Lubricants

1. Grease

Use an SAE multipurpose high temperature grease with extreme pressure (EP) performance. Also acceptable is an SAE multipurpose lithium base grease.

2. Storing Lubricants

Your machine can operate at top efficiency only if clean lubricants are used. Use clean containers to handle all lubricants. Store them in an area protected from dust, moisture, and other contaminants.

3. Power Pack Hydraulic Oil

Use Dexron® III ATF for all operating conditions. Dexron VI or Mercon® are acceptable substitutes.

7.2 Greasing

1. Use a hand-held grease gun for all greasing.
2. Wipe grease fitting with a clean cloth before greasing, to avoid injecting dirt and grit.
3. Replace and repair broken grease fittings immediately.
4. If fittings will not take grease, remove, and clean thoroughly. Clean lubricant passageway. Replace fittings if necessary.

Location	Grease Points – Every 50 hours or annually
1	Lower Log Stabilizer Pivot
2	Upper Log Stabilizer Pivot
3	Push Block Slide
4	Winch
5	Wedge Adjustment Arm bushing

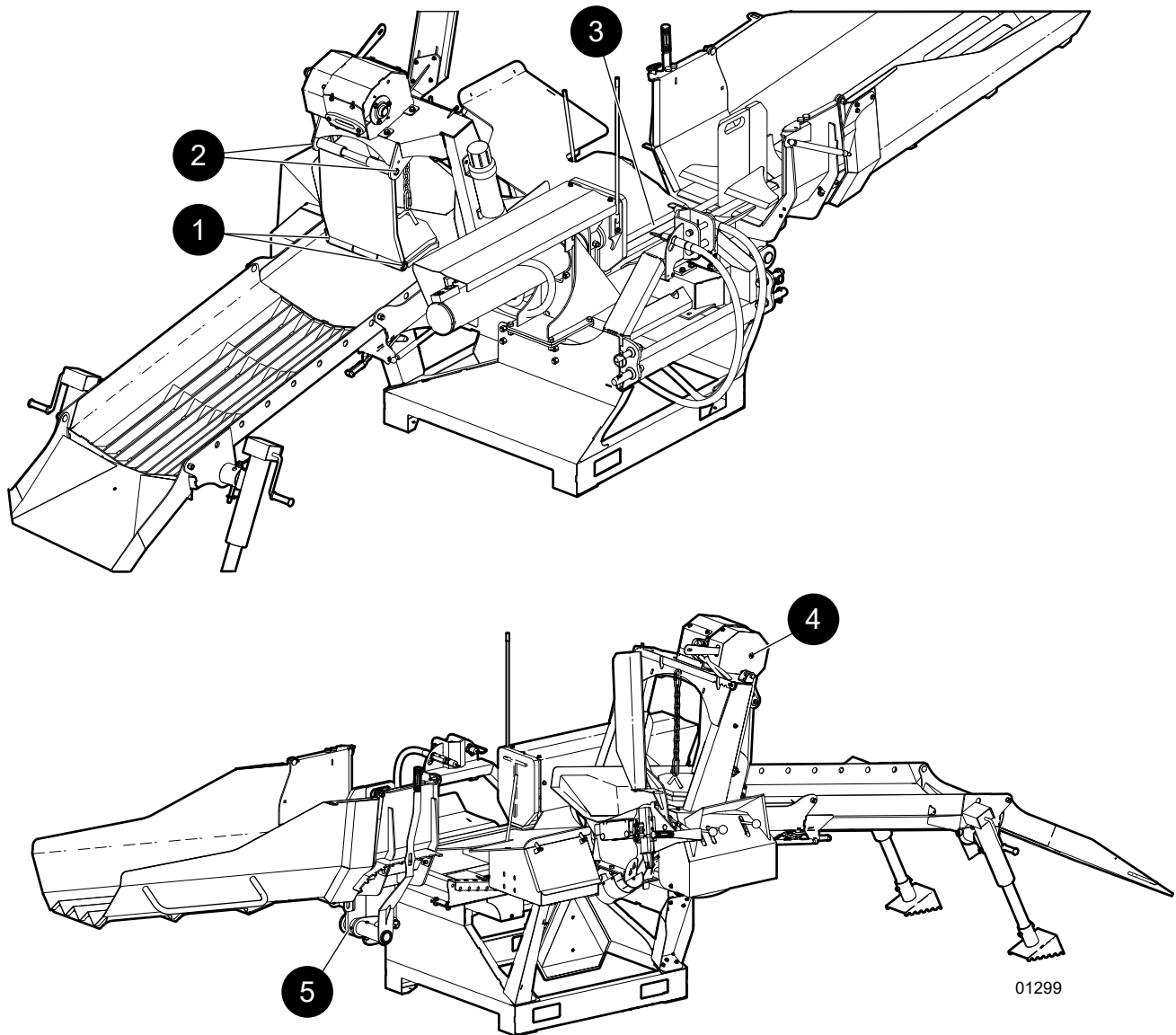

Fig. 48–Grease points

7.3 Maintenance Schedule

Perform at time shown or hour interval, whichever comes first. Item	Every 8 hours or Daily	Every 50 hours or Annually	Every 100 hours or Annually	Reference
Winch Rope Condition	●			
Check hydraulic hoses, fittings, frame slide	●			
Check that all fasteners are secure	●			
Check hydraulic oil level	●			
Grease frame slide, hinges, pivot points		●		
Change hydraulic oil filter (power pack equipped models)			●	See page 42
Clean machine			●	

7.4 Power Pack Option—Maintenance

NOTE: This procedure is for the Optional Power Pack. Please refer to your tractor's maintenance guide concerning hydraulic oil and filter service instructions.

CAUTION!



Risk of burns to exposed skin. Hydraulic oil becomes hot during operation. Hoses, lines and other parts become hot as well. Wait for the oil and components to cool before starting any maintenance or inspection work.

W028

7.4.1 Drain and replace oil

Change hydraulic oil every 100 hours or annually.

Make sure tractor engine is off and all controls are in neutral.

Allow the machine to cool before changing the oil. Hot oil can cause burns if it contacts exposed skin. It is best to change oil while the machine is warm to keep the contaminants in suspension.

1. Place a pan of suitable capacity under the hydraulic oil reservoir drain. Reservoir holds 7.1 US gal (27 L).
2. Remove the drain plug to drain the oil.

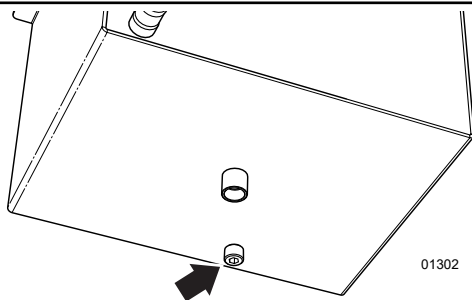

Fig. 49—Oil reservoir drain plug

3. Replace the drain plug and fill the reservoir with Dexron® III ATF for all operating conditions. Dexron VI or Mercon® are acceptable substitutes.
4. Operate the machine for 1–2 minutes while operating cylinder. Recheck oil level. Oil level should be approximately 1" (25 mm) from the top of the tank.
5. Check for leaks at the drain.

Dispose of the old or any spilled oil in an approved manner.

7.4.2 Remove and clean the filter

Remove and clean oil filter every 100 hours or annually. The filter is washable.

NOTE: The tank does not have to be drained to clean the filter.

1. Remove the 3 screws from the oil filter cover on the top of the reservoir.
2. Remove the filter cover and pull out the hydraulic oil filter.
3. Wash the filter screen with mineral spirits (Varsol™). Inspect the filter mesh for any holes, perforation, rust, or tears.
4. Place the filter screen into the tank and secure the filter cover.

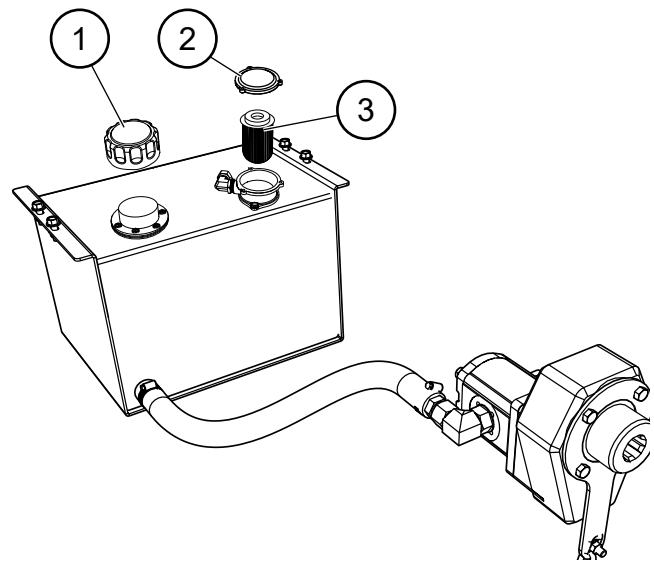

Fig. 50—Reservoir filler cap and filter

1. Filler Cap
2. Filter Cover
3. Filter

8. Trouble Shooting

The Wallenstein Wood Processor uses hydraulic power to move a hydraulic cylinder rod to split wood or logs. It is a simple and reliable system that requires minimal maintenance.

In the following table, we have listed many of the problems, causes and solutions to the problems that you may encounter.

If you encounter a problem that is difficult to solve, even after having read through this trouble shooting section, please call your local dealer, distributor, or Wallenstein. Before you call, please have the serial number for your Wood Processor handy.

Problem	Cause	Solution
Winch motor does not move	Rope jammed	Disengage winch gears, pull rope out and guide rope on to the spool when retracting
Rope does not pull out	Winch gears engaged	Disengage winch gears
Rope does not retract	Winch gears disengaged	Engage winch gears
Cylinder rod moves slowly or does not move.	Wood jammed around wedge.	Shut machine off and safely remove wood.
Cylinder rod / Winch motor moves slowly or does not move.	No pressurized hydraulic oil.	Oil filter plugged. Change filter.
	No pressurized hydraulic oil	Low hydraulic oil level, top up
	Not enough pressure.	Call technician, system relief setting may be low.
	Low engine speed.	Check that choke is off, check throttle is set to maximum.
Control handle doesn't go to neutral after rod is fully retracted.	Detent set too tight.	Call technician, adjustment required with detent on valve.
	Hydraulic fluid too cold.	Allow machine to warm up.
	Hydraulic fluid is too old or contaminated.	Change hydraulic fluid and filter
Control handle goes to neutral before rod is fully retracted.	Detent set too loose.	Call technician, adjustment required with detent on valve.
Control handle doesn't go to neutral when released.	Control may be damaged.	Call technician, control may need service or be replaced.
Cylinder stops on contact with wood.	Second stage on pump not functioning.	Call technician, pump may need service or be replaced.
Wedge jumps.	Wedge frame jamming.	Lubricate wedge frame wear plates.
Leaking hydraulic hose.	Hose worn or damaged.	Replace hose.
Leaking cylinder.	Seals worn.	Call technician, seal replacement may be required.

9. Specifications

9.1 Machine Specifications¹

Model	WP245	WP275
Recommended Minimum Power	45 hp (33.1 kW)	45 hp (33.1 kW)
Recommended Pump Flow	12–24 US gpm (45–91 Lpm)	
Cylinder Diameter / Stroke	4.50" / 25.75" (121 mm / 654 mm)	4.50" / 37.75" (121 mm / 959 mm)
Splitter Control Valve Type	Dual Valve Open Center with Auto Cycle Detent	
Full Stroke Splitting Cycle Time	Varies depending on tractor flow and power	
Splitting Force	20–25 ton / tonne @ 2550–3000 psi	
Maximum Split Length	27" (69 cm)	39" (99 cm)
Maximum Log Diameter	22" (56 cm)	
Wedge Configuration	Adjustable 4-Way	
Mounting	3-Point Hitch Category I, II Mounting	
Weight	1614 lb (732 kg)	1785 lb (810 kg)
Dimensions Extended (L x W x H)	220" x 60" x 66" (559 cm x 152 cm x 168 cm)	244" x 60" x 66" (620 cm x 152 cm x 168 cm)
Dimensions Folded (L x W x H)	126" x 60" x 79" (320 cm x 152 cm x 201 cm)	161" x 60" x 79" (409 cm x 152 cm x 201 cm)
Winch	Hydraulic, Control Valve Operated	
Winch Rope Length	50' (15.2 m)	
Winch Rope Diameter	1/4" (6 mm)	
Winch Pulling Force	1550 lb (703 kg)	
Discharge Chute Height	54" (1.4 m) maximum	
Winch Strap	60" (1,5 m)	
Accessories	Adjustable 6-way Wedge	
	Nylon Chain saw Holster	
	48" (1.2 m) Log Peavey	
	Firewood Net Frame	
	Firewood Net	
Options	Hydraulic PTO Pump Kit – 7 US gal (27 L) reservoir and hydraulic pump rated for 15 gpm (57 Lpm) @ 540 rpm.	

¹ Specifications subject to change without notice

9.2 Common Bolt Torque Values

Checking Bolt Torque

The tables shown give correct torque values for various bolts and capscrews. Tighten all bolts to the torques specified in the table, unless specified otherwise. Check tightness of bolts periodically.

IMPORTANT! If replacing hardware, use fasteners of the same grade.

IMPORTANT! Torque figures indicated in the table are for non-greased or non-oiled threads. Do not grease or oil threads unless indicated otherwise. When using a thread locker, increase torque values by 5%.

 **NOTE:** Bolt grades are identified by their head markings.

Imperial Bolt Torque Specifications						
Bolt Diameter	Torque Value					
	SAE Gr. 2		SAE Gr. 5		SAE Gr. 8	
	lbf•ft	N•m	lbf•ft	N•m	lbf•ft	N•m
1/4"	6	8	9	12	12	17
5/16"	10	13	19	25	27	36
3/8"	20	27	33	45	45	63
7/16"	30	41	53	72	75	100
1/2"	45	61	80	110	115	155
9/16"	60	95	115	155	165	220
5/8"	95	128	160	215	220	305
3/4"	165	225	290	390	400	540
7/8"	170	230	420	570	650	880
1"	225	345	630	850	970	1320



SAE Gr. 2



SAE Gr. 5



SAE Gr. 8

Metric Bolt Torque Specifications				
Bolt Diameter	Torque Value			
	Gr. 8.8		Gr. 10.9	
	lbf•ft	N•m	lbf•ft	N•m
M3	0.4	0.5	1.3	1.8
M4	2.2	3	3.3	4.5
M6	7	10	11	15
M8	18	25	26	35
M10	37	50	52	70
M12	66	90	92	125
M14	83	112	116	158
M16	166	225	229	310
M20	321	435	450	610
M30	1,103	1 495	1,550	2 100



8.8



10.9

9.3 Hydraulic Fitting Torque

Tightening Flare Type Tube Fittings

1. Check flare and flare seat for defects that might cause leakage.
2. Align tube with fitting before tightening.
3. Hand-tighten swivel nut until snug.
4. To prevent twisting the tube, use two wrenches. Place one wrench on the connector body and tighten the swivel nut with the second. Torque to values shown.

If a torque wrench is not available, use the FFFT (Flats From Finger Tight) method.

Hydraulic Fitting Torque							
Tube Size OD	Hex Size Across Flats	Torque value		Flats From Finger Tight			
		Inches	Inches	lbf•ft	N•m	Flats	Turns
3/16	7/16			6	8	2	1/6
1/4	9/16			11–12	15–17	2	1/6
5/16	5/8			14–16	19–22	2	1/6
3/8	11/16			20–22	27–30	1-1/4	1/6
1/2	7/8			44–48	59–65	1	1/6
5/8	1			50–58	68–79	1	1/6
3/4	1-1/4			79–88	107–119	1	1/8
1	1-5/8			117–125	158–170	1	1/8

Values shown are for non-lubricated connections.

10. Accessories

Contact your dealer for pricing and availability

Nylon Chain saw Holster

Safely holds your second chain saw keeping it off the ground and out of the way.

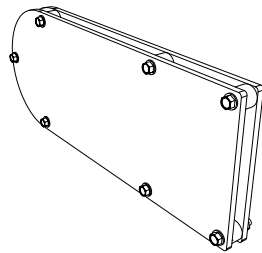

6-Way Wedge

Boost your productivity and make quick work out of chunks by splitting into six pieces at once.

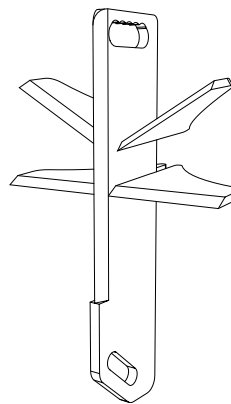

Log Peavey – 48" (1.2 m)

Helps to move those heavy log timbers into position and through the Wood Processor.

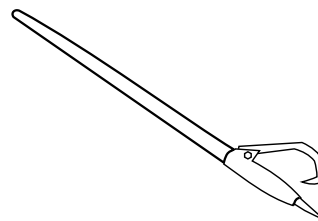

11. Product Warranty



LIMITED WARRANTY

Wallenstein products are warranted to be free of defects in materials and workmanship under normal use and service, for a period of

Five Years for Consumer Use

Two Years for Commercial/Rental Use

from the date of purchase, when operated and maintained in accordance with the operating and maintenance instructions supplied with the unit. Warranty is limited to the repair of the product and/or replacement of parts.

This warranty is extended only to the original purchaser and is not transferable.

Repairs must be done by an authorized dealer. Products will be returned to the dealer at the customer's expense. Include the original purchase receipt with any claim.

This warranty does not cover the following:

- 1) Normal maintenance or adjustments
- 2) Normal replacement of wearable and service parts
- 3) Consequential damage, indirect damage, or loss of profits
- 4) Damages resulting from:
 - Misuse, negligence, accident, theft or fire
 - Use of improper or insufficient fuel, fluids or lubricants
 - Use of parts or aftermarket accessories other than genuine Wallenstein parts
 - Modifications, alteration, tampering or improper repair performed by parties other than an authorized dealer
 - Any device or accessories installed by parties other than an authorized dealer
- 5) Engines. Engines are covered by the manufacturer of the engine for the warranty period they specify. For the details of your engine warranty, see your engine owner's manual. Information about engine warranty and service is also available in the FAQ section at www.wallensteinequipment.com

rev. Nov-2018

12. Alphabetical Index

A		O	
Accessories.....	47	Operating Instructions.....	25
Adjustable Log Length Guide.....	20	Attaching Chain Saw to Holder.....	28
Attaching / Unhooking.....	22	Cutting.....	34
Connecting Tractor Hydraulic Circuit.....	23	Emergency Stopping.....	30
Auto Cycle.....	18	Last Log.....	36
C		Machine Break-In.....	36
Chain Saw, Attaching to Pivot.....	28	Machine Set-Up.....	26, 27
Chain Saw Safety.....	9	Next Log.....	35
Common Bolt Torque Values.....	45	Operating Safety.....	25
Components.....	17	Pre-Operation Checks.....	25
Connecting Tractor Hydraulic Circuit.....	23	Setting Log Stop Guide.....	29
Controls.....	18	Splitting.....	34
Adjustable Log Length Guide.....	20	Starting.....	30
Attaching / Unhooking.....	22	Stopping.....	30
Hydraulic Controls.....	18	Storage.....	38
Hydraulic Controls and Auto Cycle.....	18	Timesaving Steps.....	36
Log Stop Guide.....	29	Transporting.....	37
Splitter Chute Height Adjuster.....	21	Winching.....	31, 32, 33
Splitting Wedge Height Lever.....	20	Operating Safety.....	25
Winch Gear Lever.....	19	Optional Power Pack, Connecting.....	24
Creating a Safe Work Area.....	10	P	
Cutting.....	34	Power Pack Option–Maintenance.....	42
D		Pre-Operation Checks.....	25
Decals, Types of.....	6	Processing Operation	
Safety Sign Explanations.....	12	Cutting.....	34
E		Efficient Processing.....	36
Efficient Processing.....	36	Last Log.....	36
Emergency Stopping.....	30	Next Log.....	35
Equipment Safety Guidelines.....	8	Splitting.....	34
F		Winching.....	31
Familiarization.....	16	R	
Job Site Familiarization.....	16	Replacing Damaged Safety Signs.....	15
To the New Operator.....	16	S	
H		Safe Condition.....	8, 39
Hydraulic Control Levers.....	18	Safety.....	7
Auto Cycle.....	18	A Safe Work Area.....	10
Hydraulic Controls.....	18	Chain Saw Safety.....	9
Hydraulic Fitting Torque.....	46	Equipment Safety Guidelines.....	8
Hydraulic System Safety.....	9	Hydraulic System Safety.....	9
L		Safe Condition.....	8
Last log, Processing.....	36	Safety Alert Symbol.....	7
Log Stop Guide.....	29	Safety Rules.....	7
M		Signal Words.....	7
Machine Break-In.....	36	Safety Alert Symbol.....	7
Machine Components.....	17	Safety Notice Decals.....	6
Machine Serial number.....	5	Safety Rules.....	7
Machine Set-up		Safety Sign Locations.....	12
Attaching Saw to Chain Saw Holder.....	28	Safety Signs	
Setting Log Stop Guide.....	29	Safety Sign Locations.....	12
Maintenance Decals.....	6	Service and Maintenance.....	39
Maintenance Schedule.....	41	Fluids and Lubricants.....	39
L		Greasing.....	40
Last log, Processing.....	36	Maintenance Schedule.....	41
Log Stop Guide.....	29	Power Pack Option Maintenance.....	42
M		Sign-off form.....	11
Machine Break-In.....	36	Specifications.....	44
Machine Components.....	17		
Machine Serial number.....	5		
Machine Set-up			
Attaching Saw to Chain Saw Holder.....	28		
Setting Log Stop Guide.....	29		
Maintenance Decals.....	6		
Maintenance Schedule.....	41		

Common Bolt Torque Values	45
Hydraulic Fitting Torque	46
Machine Specifications	44
Splitter Chute Height Adjuster	21
Splitting	34
Splitting Wedge Height Lever.....	20
Starting.....	30
Stopping.....	30
Storage.....	38
Placing Wood Processor in Storage	38
Removing From Storage.....	38

T

Transporting	37
Troubleshooting	43

W

Warranty.....	48
Wedge.....	20, 47
Winch	18
Winch Gear Lever	19
Winching	31



A series of 20 horizontal lines spanning the width of the page, providing a template for writing.



www.wallensteinequipment.com